

ORTAL®

Installation and Operation Manual Wilderness 77 Series

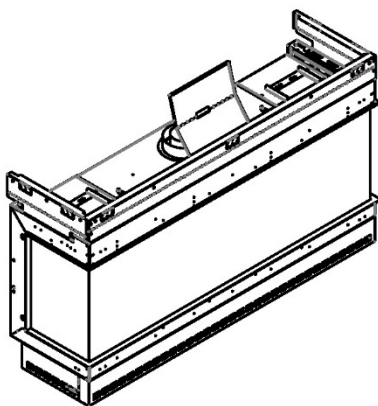
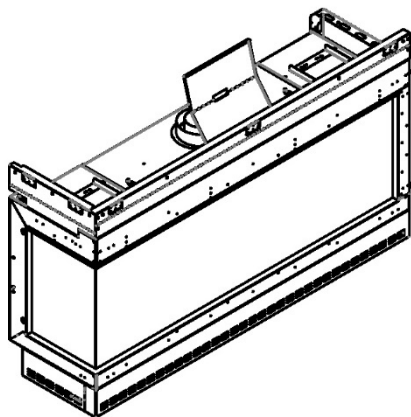
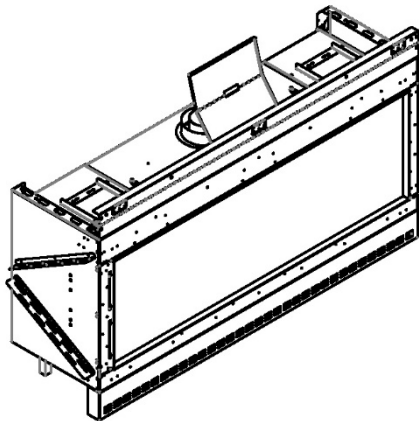

Wilderness 77 Series Fireplaces:

Wilderness 77 Front Facing

Wilderness 77 Corner (RS/LS)

Wilderness 77 Three Sided

(Ortal Power Vent Max is required for Wilderness 77 fireplaces)

⚠ WARNING:

FIRE OR EXPLOSION HAZARD

Failure to follow safety warnings exactly could result in serious injury, death, or property damage.

- **DO NOT** store or use gasoline or other flammable vapors and liquids in the vicinity of this or any other appliance.
- **What to do if you smell gas:**
 - **DO NOT** try to light any appliance.
 - **DO NOT** touch any electrical switch. **DO NOT** use any phone in your building.
 - Leave the building immediately.
 - Immediately call your gas supplier from a neighbor's phone. Follow the gas supplier's instructions.
 - If you cannot reach your gas supplier, call the fire department.
- Installation and service must be performed by a qualified installer, service agency, or the gas supplier.

! DANGER



**HOT GLASS WILL
CAUSE BURNS.**

**DO NOT TOUCH GLASS
UNTIL COOLED.**

**NEVER ALLOW CHILDREN
TO TOUCH GLASS.**

A barrier designed to reduce the risk of burns from the hot viewing glass is provided with this appliance and must be installed for the protection of children and other at-risk individuals.

INSTALLER: Leave this manual with the appliance.

CONSUMER: Retain this manual for future reference.



Safety Information and Warnings













-  **IMPORTANT NOTE: LOCAL CODE**
Local codes and regulations that are more stringent than the requirements in this manual take precedence over Ortal requirements.
-  **WARNING: REVIEW ALL WARNINGS**
Be sure to review all safety warnings and installation guidelines contained in this manual. Consider installation location, vent configuration, clearances, structural requirements, framing and finish materials, and local codes. ALL warnings and instructions apply to all products manufactured and distributed by Ortal.
-  **WARNING: DO NOT OPERATE FIREPLACE IF:**
The glass is NOT properly secured in place; Connection points are not sealed (for fireplaces with glass-to-glass connections); Glass is cracked; You smell gas; Any part of the fireplace has been under water; You have any doubt about safe operation of the fireplace; Or if any part has been under water, do not use the fireplace. Immediately call a qualified, professional service technician to inspect the fireplace and to replace any parts of the control system and any gas controls which have been under water.
-  **WARNING: ELECTRICAL GROUNDING**
All electrical connections must be properly installed, insulated, and secured to avoid potential **ELECTRICAL SHOCK** and **FIRE HAZARD** and malfunction of the system. Consult local building code requirements. In the absence of local codes, refer to the National Electric Code, ANSI/NFPA 70, or the Canadian Electric Code, CSA C22.1.
-  **WARNING: MATERIAL USAGE**
All materials and objects used to carry out the installation must be certified/approved or specified by Ortal and are suitable for use. Do NOT install the system with different materials or objects than those approved for installation by Ortal.
-  **WARNING: INSTALLATION AND SERVICE**
Installation and repairs on the fireplace and vent system must be done by an authorized Ortal qualified installer service agency or gas supplier. If these components are not installed by an authorized Ortal dealer/installer, the warranty of all components will be void and Ortal will not be responsible for any damage caused by improper installation. The fireplace should be inspected before use and at least annually by a professional service person. More frequent cleaning may be required due to excessive lint from carpeting, bedding material, etc. Control compartments, burners and circulating air passageways of the fireplace must be kept clean. Any alteration to the product can cause soot or carbon to form and may result in damage. This damage and any other damage that results from not following the instructions outlined in this manual is not the responsibility of Ortal.
-  **WARNING: HEAT BARRIER**
A barrier designed to reduce the risk of burns from hot viewing glass is provided with this fireplace and shall be installed. The fireplace **MUST** not be used without the heat barrier in place. If the barrier becomes damaged, the barrier shall be replaced with the manufacturer's barrier for this fireplace. **Any safety screen, guard, or barrier removed for servicing the fireplace must be replaced before operating.**
-  **WARNING: FIREPLACE TEMPERATURE**
Due to hot temperatures, the fireplace should be located out of traffic and away from furniture and draperies. Children and adults should be alerted to the hazards of high surface temperature and should stay away to avoid burns or clothing ignition. Clothing or other flammable material should not be placed on or near the fireplace. **Young children should be carefully supervised when they are in the same room as the fireplace.** Toddlers, young children, and others may be susceptible to accidental contact burns. A physical barrier is recommended if there are at-risk individuals in the house. To restrict access to a fireplace or stove, install an adjustable safety gate to keep toddlers, young children, and other at-risk individuals out of the room and away from hot surfaces.
-  **WARNING: GLASS HANDLING**
Only an Ortal certified installer is authorized to remove the glass using an 8-inch glass-handling suction cup.
-  **WARNING: INSTALLATION AND OPERATION**
The fireplace and accompanying components must be installed as an OEM installation in manufactured homes (USA only) or an aftermarket permanently located, or a mobile home, where not prohibited by local codes. The fireplace must be installed in accordance with the Manufacturer's instructions and the Manufactured Home Construction and Safety Standard, Title 24 CFR, Part 3280, in the United States, or the Standard for Installation in Mobile Homes, CAN/CSA Z240 MH Series, in Canada. **Exceeding the restrictions imposed in these instructions may result in a fire or explosion, causing property damage, personal injury, or loss of life. Ortal will not be responsible for any damage caused by improper installation. Do not store or use gasoline or other flammable vapors and liquids near this fireplace.**
-  **WARNING: GAS FIREPLACE**
This fireplace is for use only with the type of gas indicated on the rating plate. These fireplaces are not convertible for use with other gases unless a certified kit is used, and the conversion is performed by an authorized and qualified technician. Applicable standards are Vented Gas Fireplace Heaters ANSI Z21.88 / CSA 2.33a and Gas-fired Fireplaces for Use at High Altitudes CAN/CGA 2.17-M91
-  **WARNING: CALIFORNIA PROP 65**
These products and the fuels used to operate these products (liquid propane or natural gas), and the products of combustion of such fuels, can expose you to chemicals including benzene, carbon monoxide, and ceramic fibers, which are known to the state of California to cause cancer and/or reproductive harm. For more information, visit www.p65warnings.ca.gov.

Table of Contents

“→” Denotes new or changed information from most recent version manual.

General	2
Safety Information and Warnings	2
Product Information	5
Models	5
Certification	5
Rating Label	6
Stand-Offs	7
Installation	8
Prior to Installation	8
Locate the Fireplace	8
Fireplace Installation	8
Planning	8
Installation	8
Startup	9
Post-Installation	9
Initial Burning Period	9
Final Inspection Procedure	9
Final Checks and User Instruction	9
Building Around the Fireplace	10
→Building Checklist	10
Framing	11
Framing Requirements	11
⁵ / ₈ " Type X Drywall Requirements	11
Chase Floor/Platform	11
Framing Dimensions	12
General Clearances	15
Heat Release	15
Air Intake Opening	18
Mounting a TV/Artwork	20
Access Area Requirements	22
Protective Cover for Double Glass Fans	22
Chase Area Minimum	22
Recessed Ledge Detail	23
Structural Weight Support	24
Finishing	24
Flush Installation	25
Recessed Installation	26
Maximum Overhang/Mantel Depth	26
Venting	27
Power Vent Max System	27
Inline Power Vent Max	27
Horizontal End-Line Power Vent Max	34
Venting Requirements	43
Vent Configurations	43
Vent Restrictor Sizing Guidelines	43
Vent Clearances	44
Chimney Shroud	45
Vent Installation	45
Vent Maintenance	45
Gas	46
Gas Pressures	46
Routing the Gas Line	46
Gas Conversion	47
High Altitude Requirements	47
→Gas and Electrical Components	48
Electrical	48
Electrical Requirements	48
Power Outage	49
Pairing the Remote and Receiver	49

→Wiring Diagrams	50
Home Automation Wiring Diagram	51
Driftwood Firelog Set	51
Firelog Installation Warnings	52
Firelog Setup	53
Log Base Position Adjustment	57
Adjustment Instructions	58
Operation	62
10-Button Remote Control Handset	62
Operating Instructions	62
Puck Handset	63
Operating Instructions	64
Wall Switch	65
Operating Instructions	65
Fireplace Maintenance	66
General Maintenance	66

Product Information

Models

Wilderness 77 Series fireplaces are required to be used with the Ortal Power Vent Max system for optimal operation.

Series	Models	Firelog Burner	Certification Standard	Gas Types	Direct Venting
Wilderness 77	Wilderness 77 Front Wilderness 77 RS Wilderness 77 LS Wilderness 77 TS	Driftwood 135-3 (3 long logs)	US: ANSI Z21.88-2019 Canada: CSA 2.33-2019	Natural Gas or Propane	Type: Power Vent (Power Vent Max) Vent Size: 5"x8" (co-axial)

NOTE: Venting is not supplied by Ortal with the fireplace. The fireplace is certified to be used with, and can be obtained from, the vent manufacturers outlined in "Venting Requirements" section.

POWER VENT NOTE: While an Ortal Power Vent Max (using 5"x8" pipe) is the recommended choice, under the few circumstances where a Power Vent Max might not be the perfect fit, the Enervex RS Power Vent (using 5"x8" pipe) can be substituted. For more information on the Enervex RS Power Vent System, refer to the Ortal Enervex RS Power Vent System manual.

Certification

Wilderness 77 series fireplaces have been tested and approved by CSA Group for safety and efficiency for use with Natural Gas (NG) and Propane (LP) only, and **NOT** for use with solid fuels.

CSA Group is approved by the American National Standards Institute (ANSI) as an Accredited Standards Developer.

Certification Standard:

US: ANSI Z21.88 – 2019: Vented Gas Fireplace Heaters

Canada: CSA 2.33 – 2019: Vented Gas Fireplace Heaters



Products:

CLASS 2901 84: DOMESTIC HEATERS (GAS) Vented Fireplace: Certified to US Standard

CLASS 2901 04: DOMESTIC HEATERS (GAS) Vented Fireplace

The fireplaces are permitted for indoor use only. "Indoor" is defined as a conditioned space. The fireplaces are not approved for outdoor or partial outdoor installation. The fireplaces must be installed while maintaining required clearances. Installation is recommended in living spaces such as bedrooms, living rooms, great rooms, etc. The fireplaces are not approved for closet installation. The fireplace must be installed according to Ortal requirements in addition to any local codes that may apply, such as USA: ANSI Z223.1/NFPA 54, Canada: CSA B149.

IMPORTANT:

- Consult the authority having jurisdiction to determine the need for a permit prior to starting the installation.
- It is the responsibility of the fireplace dealer and installer to ensure that this fireplace is installed and framed in compliance with these instructions and all applicable codes.
- Before starting, take careful note of **ALL** the **WARNINGS** in this manual.





Rating Label

DEALERS/INSTALLERS:

You **MUST** leave the fireplace's rating label with the fireplace in an area easily accessible by the owner (typically near the access panel, if available). You must instruct the owner before handing over the fireplace where this label can be found.

OWNERS:

Make sure the installer leaves your fireplace's rating label in an area that is easily accessible for you. This information is required for servicing and receiving replacement parts.

		  	
Manufacturer/Fabricant Ortal Ltd. 14 Haharash St. Hod Hasharon, 4524087 Israel Tel: 011-972-9-7402828 Fax: 011-972-9-7402687		For use only with vent, glass and interior design media certified and approved for use with the appliance. Not for use with solid fuel. For use with barriers certified for this appliance only. Utilisez uniquement avec des conduits, des panneaux vitrés et des accessoires décoratifs intérieurs homologués et approuvés pour une utilisation avec cet appareil. Pas pour l'usage avec le combustible solide. Pour une utilisation avec des barrières certifiées pour cet appareil uniquement.	
Serial No.: 	Approved By: CSA No.: 2358468 Homologué Par:		
Tested to: CSA/ANSI Z21.88-2019 • CSA 2.33-2019 for Vented Gas Fireplace Heater Examiné à: CSA/ANSI Z21.88-2019 • CSA 2.33-2019 pour Poêles-foyers ventilés			
Altitude rating: Estimation d'altitude:	0-2000 ft. / 0-610 m.	Electrical Rating: Estimation Électrique:	120 volt / 60 Hz / less than 5A
Model Series / Modèle Séries: Wilderness Burner 135-3			
<input type="checkbox"/> Wilderness 60 H/HH FR/RS/LS/TS/TU/SC/SA <input type="checkbox"/> Wilderness 77 H/HH FR/RS/LS/TS/TU/SC/SA <input type="checkbox"/> Wilderness 68 H/HH FR/RS/LS/TS/TU/SA <input type="checkbox"/> Wilderness 98 H/HH FR/RS/LS/TS/TU/SA			
Fuel Type/Type de combustible:	<input type="checkbox"/> NG/GN	<input type="checkbox"/> PROPANE	
Max Input / Débit max. (BTU/HR):	61,000	57,000	
Min Input / Débit min.(BTU/HR):	41,000	50,000	
Orifice Size / Taille de l'orifice:	500-160-380 800	260-60-180 380	
Gas Inlet Pressure (W.C.) inches: Pression d'entrée de gaz (CE) pouces:	11.0	13.0	
Gas manifold Pressure (W.C.) inches: Pression d'alimentation (CE) pouces:	3.5	5.0	
Clearances to Combustibles (with included standoffs): Espacement par rapport aux matériaux inflammables (avec entretoises inclus):	Sides: Côtés: 0"	Back: Arrière: 0"	In front of Glass Devant le panneau vitré: 16"
Also adhere to clearance diagrams and instructions included in the ORTAL manual. Adhérer également aux schémas d'espacement et des instructions figurant dans le manuel ORTAL.			
SKU: M209-WD135-3-24			

Wilderness 77 Series Driftwood 135-3 Rating Label

Stand-Offs

The fireplace has stand-offs fastened to the body of the fireplace as shown in the figures below. Stand-offs must be fully extended upon installation.

Heat Shield: Attached to the top front part of the fireplace. It is foldable at the attachment site on top of the fireplace and $\frac{2}{3}$ to the top of the shield. The heat shield serves to direct the heat coming out of the heat barrier vents at the top of the fireplace and maintains clearance to the vent pipe.

Side & Back Framing Stand-offs: Attached to the sides and back of the fireplace. These stand-offs keep enough distance from the fireplace to the framing to allow for proper airflow inside the chase. These stand-offs can directly touch combustible framing.

Front Framing Stand-offs: Attached to the front top portion of the fireplace above the glass viewing area. It keeps a clearance above the heat barrier vents on the top of the fireplace to ensure proper air flow inside the chase. The top of this stand-off can directly touch combustible framing. Any framing in front of the stand-off must be non-combustible.

Protective Cover: Attached under the bottom front part of the fireplace to protect the double glass fans during shipping and installation. This cover is present on double glass models only and needs to be removed after setting the unit in place. Screen models do not come with a protective cover.

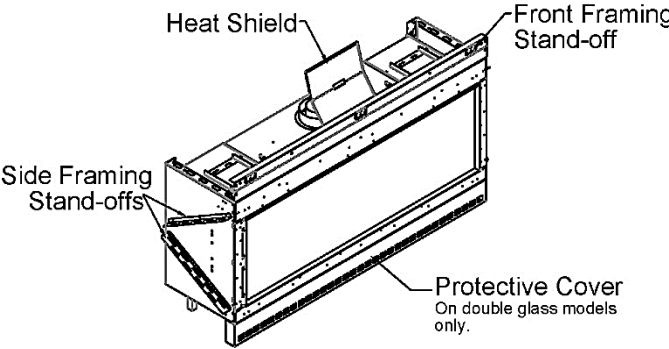
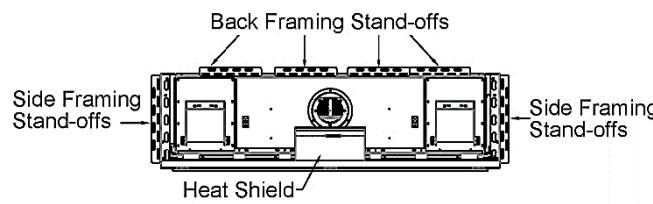
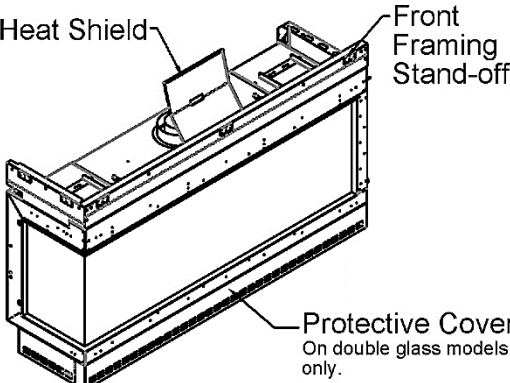
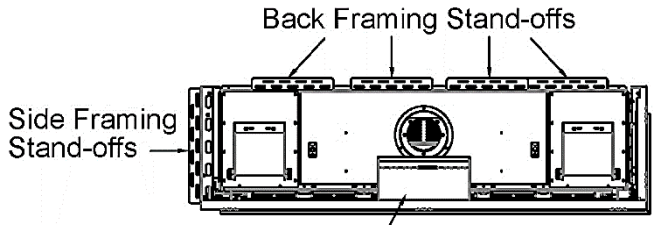
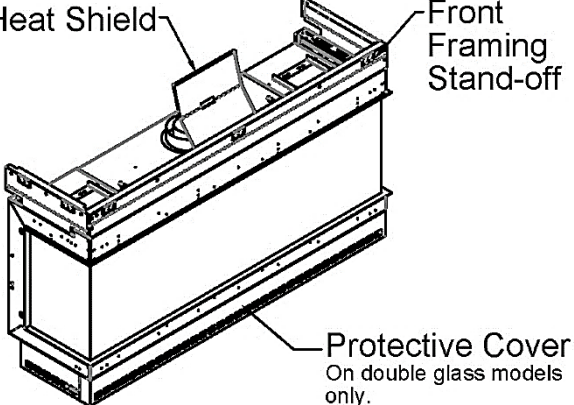
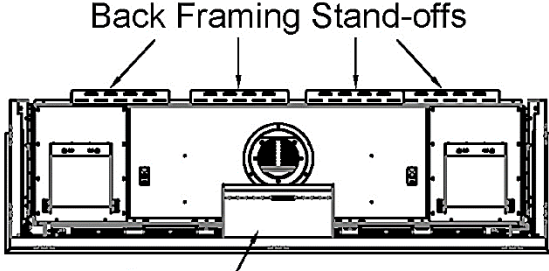
Wilderness 77 Series Front Facing	
 <p style="text-align: center;">Zero-Clearance Stand-Offs (Isometric View)</p>	 <p style="text-align: center;">Zero-Clearance Stand-Offs (Top View)</p>
Wilderness 77 Series Corner (RS/LS)	
 <p style="text-align: center;">Zero-Clearance Stand-Offs (Isometric View)</p>	 <p style="text-align: center;">Zero-Clearance Stand-Offs (Top View)</p>
Wilderness 77 Series Three Sided	
 <p style="text-align: center;">Zero-Clearance Stand-Offs (Isometric View)</p>	 <p style="text-align: center;">Zero-Clearance Stand-Offs (Top View)</p>

Installation

Prior to Installation

Locate the Fireplace

Keep the following factors in mind when selecting a location for the fireplace:

- Fireplace clearance requirements (review “General Clearances” section).
- Heat release and air intake requirements (review “Heat Release” section and “Air Intake Opening” section).
- Adequate space for servicing.
- Access area requirements (review “Access Area Requirements” section).
- Minimum vertical vent rise, allowed horizontal lengths, and number and orientation of elbows (review “Venting” section).
- Framing and finishing requirements (review “Framing” section and “Finishing” section).
- Floor or Platform requirements (review “Chase Floor/Platform” section).

Fireplace Installation

Use the following guidelines to ensure a smooth installation. The installation sequence is divided into three phases: Planning, Installation, and Startup.

Planning

Consult with the contractor and go over all requirements:

- Chase framing requirements.
- $\frac{5}{8}$ " Type X Drywall (or equivalent) requirements.
- Heat release requirements.
- Air Intake requirements (if applicable).
- Access area size and location.
- Gas and electrical specs and location.
- Vent configuration.
- Finishing details.

NOTE: Provide the contractor with a printed copy of the “Building Checklist” and review requirements with them.

Installation

- Confirm the following items are properly located and built to specification:
 - Framing (with $\frac{5}{8}$ " Type X Drywall as applicable)
 - Platform
 - Gas and electrical
 - Access area
 - Heat release
 - Air intake (if applicable)
- Clear a path free of any possible obstruction to carry in the fireplace.
- Uncrate the fireplace and set in place.
- Make sure all zero-clearance metal stand-offs on the outside of the fireplace are fully extended.
- Secure the fireplace to the framing by attaching the nailing flanges to the framing. See “Securing the Fireplace” section.
- Remove all zip ties.
- Optional: Remove gas and electrical components from metal shipping plate if desired.
- Move the components to the access area location. Be mindful of the routing for future service needs.
- Install the vent components (see “Vent Installation” section) and Power Vent Max (see “Power Vent Max System” section).
- Review the front wall requirements (see “Step-by-Step Chase Construction” section) and finishing details with the contractor.
- Protect the fireplace and components from damage.

Securing the Fireplace

The fireplace has nailing flanges attached to the face of the fireplace (see figures below). The nailing flanges are to be attached into the framing upon installation. It is crucial to the finishing that the fireplace is stable, level, and plumb. For added stability (though not required), re-use the shipping brackets to secure the legs of the fireplace to floor/platform.

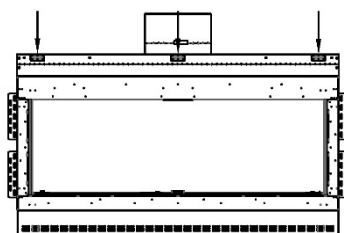

Nailing Flanges for Front Facing

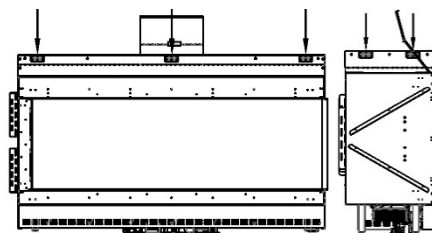

Nailing Flanges for Corner (RS/LS)

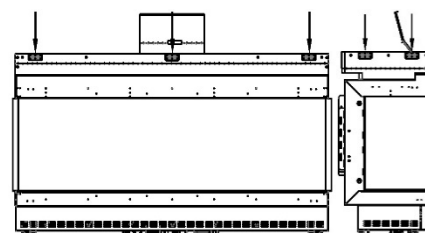

Nailing Flanges for Three Sided

Vent Installation

Venting must be installed according to the requirements detailed in the “Venting” section of this manual in conjunction with the vent system manufacturer’s installation instructions. Venting must be supported by the structural surrounding and not by the fireplace. Each elbow must be strapped to reduce movement or possible disconnection.

The first section of venting must be secured to the fireplace starter collar with a minimum of 3 sheet metal screws no longer than 1/2". DO NOT use silicone to seal the sections. If sealing is required by the vent manufacturer or local code, use Mil-Pac sealant.

Startup

- Perform a visual inspection to confirm that all work was completed correctly and per specification.
- Confirm that gas and electrical are properly connected and live.
- Remove the safety barrier and glass and clean the inside of the fireplace.
- Install media as specified in the "Driftwood Firelog Set" section .
- Confirm firelog placement is set up per specification.
- Confirm the fireplace is operating properly.
- Check remote-control setup.
- Remove protective layer from glass.
- Clean glass.
- Reinstall the glass and safety barrier.
- Review operation of the fireplace and remote control with the owner.
- Set up return visit to clean glass after the Initial Burning Period (see "Post-Installation" section)

Post-Installation

Complete the following post-installation steps.

Initial Burning Period

There is a 12-hour minimum burning period following installation of the fireplace. This 12-hour period must include a minimum of 4 consecutive hours of continuous burning. During this time, the owner or installer may notice:

- The glass developing a white or "cloudy" residue.
- An unusual smell

Both the residue and the smell are due to the paint on the fireplace metal heating and "burning off". This is normal. The cloudiness and odor will disappear after the 12-hour period elapses and the installer returns to service the fireplace and complete startup.

Final Inspection Procedure

When the 12-hour burning period is complete, the installer must return and perform the final inspection, which includes:

- Cleaning the glass with a ceramic glass cleaner (otherwise the white residue will remain)
- Checking the interior media setup
- Checking for gas leaks
- Adjusting the restrictor (if necessary)
- Performing an overall check to make sure that everything is working properly.

When these activities are complete, initial startup is concluded and the fireplace may be operated by the owner.

Final Checks and User Instruction

Before releasing the fireplace to the customer for use without installer supervision, the installer must ensure that the fireplace is burning correctly. In addition, the installer must review and explain the following to the owner:

- Safety warnings
- Fireplace operation
- Warranty requirements
- Maintenance requirements
- Glass is hot during and after operation.
- If any questions or concerns arise, owner must contact the local Ortal dealer/installer for support.

Building Around the Fireplace

→Building Checklist

The following building checklist is a quick reference for a typical Wilderness 77 series fireplace installation. This list is not exhaustive and does not supplement thorough review of the installation manual.

- ☑ **Fireplace Location:** Ensure the location allows for min. 16" clearance from viewing area to furniture and other combustibles. Make sure a clear path is established to allow the fireplace to be safely transported to installation location.
- ☑ **Exhaust Vent:** Confirm vent size (5"x8"), vent clearance (1" on sides and bottom, 3" on top), vent configuration, and termination location.
- ☑ **Height from Floor:** Fireplace leg height is 9 ⁵/₈" (to the bottom of the lower drywall lip). Legs cannot be removed/altered. If the desired viewing area location on the wall is higher than 9 ¹³/₁₆" (to the bottom viewing area), a platform can be built for the fireplace to stand on.
- ☑ **Chase Floor/Platform:** Fireplace can stand on the chase floor or a platform. A floor or platform must be able to bear the weight of the fireplace. It can be constructed out of wood, concrete, metal, or any other solid materials (not required to be non-combustible).
- ☑ **Chase Construction:** No materials can be attached directly to the fireplace (exception: ⁵/₈" Type X Drywall). The area of the chase interior must be min. 200 square inches at any given point within the chase.
- ☑ →**Framing:** Adhere to minimum framing dimensions (or greater). *When constructing the framing for the fireplace, please add up to +.25" variance to each side, and the top, of the fireplace frame. This added variance will allow added space to maneuver and adjust the fireplace when setting it in the chase.* The first 10 ⁷/₁₆" above the top of the fireplace viewing area must always be non-combustible framing. For recessed fireplaces, do not exceed 12" max. front overhang depth limit. For Corner and TS models, side overhang has no limit. No material is permitted to extend past the metal lip surrounding the fireplace viewing area.
- ☑ **⁵/₈" Type X Drywall Requirements:** One layer of ⁵/₈" Type X Drywall (or equivalent) must be installed on the exterior of the chase framing. ⁵/₈" Type X Drywall (or equivalent) may be fastened to the top framing stand-off(s) only, with 1" self-tapping drywall screws 16" on center.
- ☑ **TV/Artwork:** TV/Art must be min. 4" above top of fireplace viewing area. First 10 ⁷/₁₆" min. above the viewing area must have non-combustible framing (top front metal stand-off + non-combustible studs).
- ☑ **Gas Supply Line and Power Location:** Locate gas line with manual shut off according to local code. Power provided by a duplex outlet receptacle (120V, 15 amp, 60Hz) in same area as gas line.
- ☑ **Access Area:** An access panel, or some other form of clear access, is required at the power vent control box and the power vent fan box to access components for servicing. At the control box, min. size requirement is 12"x12". Min size requirement at the power vent is 18"x18".
- ☑ **Heat Release:** *Crucial for Cool Wall Technology.* Must start within 6" (max.) from the chase's ceiling. Min. heat release size is 200 sq.in. of net free air space for a horizontally oriented heat release. Height of the horizontal heat release must not exceed 1/3 of the width. A vertical heat release must be 260 sq. in. of net free air space.
- ☑ **Air Intake:** Only required for double glass heat barrier. Must be located at or below level of double glass fans. Min. 200 sq.in. of net free air space.
- ☑ **Finishing:** For finishes flush to the fireplace, no clearances are required. For finishes where the fireplace is recessed to the finish, maintain ¹/₈" from the finish to the front face of the fireplace.

Framing

Framing Requirements

Fireplace chase may be framed with either combustible (typically wood studs) or non-combustible framing (typically metal studs). Any framing within $10\frac{7}{16}$ " from the top of the fireplace glass (viewing area) must be non-combustible. Any framing after that point may be combustible.

The framing of the fireplace chase must be designed to carry the entire weight of the wall and finish material. Surrounding material must not transfer weight to the fireplace or be connected in any way to the fireplace, with the exception of $\frac{5}{8}$ " Type X drywall or its equivalent. **$\frac{5}{8}$ " Type X drywall may be fastened to the top framing stand-offs only, with 1-inch self-tapping drywall screws.**

No material is permitted to extend past the $\frac{5}{8}$ " deep metal drywall lip surrounding the fireplace viewing area. This area must be unobstructed to allow the heat barrier and inside glass panel to be removed.

$\frac{5}{8}$ " Type X Drywall Requirements

Exterior of the framing must be covered with $\frac{5}{8}$ " Type X Drywall (or equivalent). Chase interior does not require a layer of $\frac{5}{8}$ " Type X Drywall. This applies to both combustible and non-combustible framing.

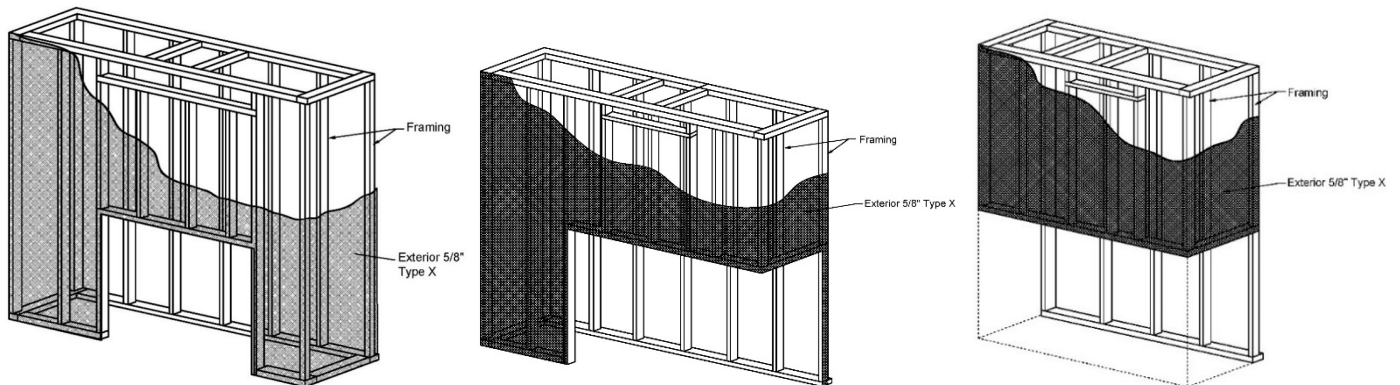

NOTE: $\frac{5}{8}$ " Type X Drywall (or equivalent) is not required on the exterior portion of an insulated outside-facing wall.

Chase Floor/Platform

The fireplace must be installed on a flat, solid, continuous surface. Surface can be wood, concrete, metal, and other typical solid floor types. Surface material is not required to be non-combustible.

Fireplace leg height is $9\frac{5}{8}$ ", measured to the bottom of the lower drywall lip. Legs cannot be removed, cut, or adjusted.

Raised Platform Option: To raise the fireplace higher than $9\frac{1}{16}$ " height (to bottom of viewing area), build a platform for the fireplace to stand on. Platform must be stable and able to bear the full weight of the fireplace. Platform can be constructed out of wood, concrete, metal, or any other solid materials. Platform material is not required to be non-combustible.

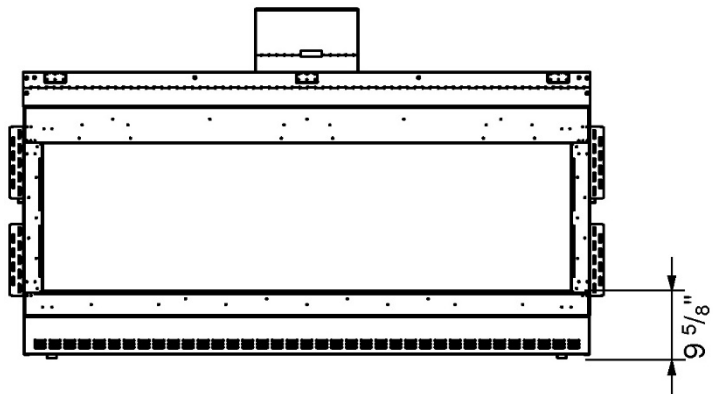

Fireplace Leg Height

NOTE: For fireplaces with the double glass heat barrier, an air intake might be necessary to incorporate into the platform depending on the design. See "Air Intake for a Platform" section for details.

Framing Dimensions

The following diagrams are for illustrative purposes only. There are multiple approved framing scenarios. A flush application is not the only permitted application. The fireplace may be recessed into the wall. Refer to diagrams and values below and in the following pages for details.

******When constructing the framing for the fireplace, please add up to +.25" variance to each side, and the top, of the fireplace frame. This added variance will allow added space to maneuver and adjust the fireplace when setting it in the chase.

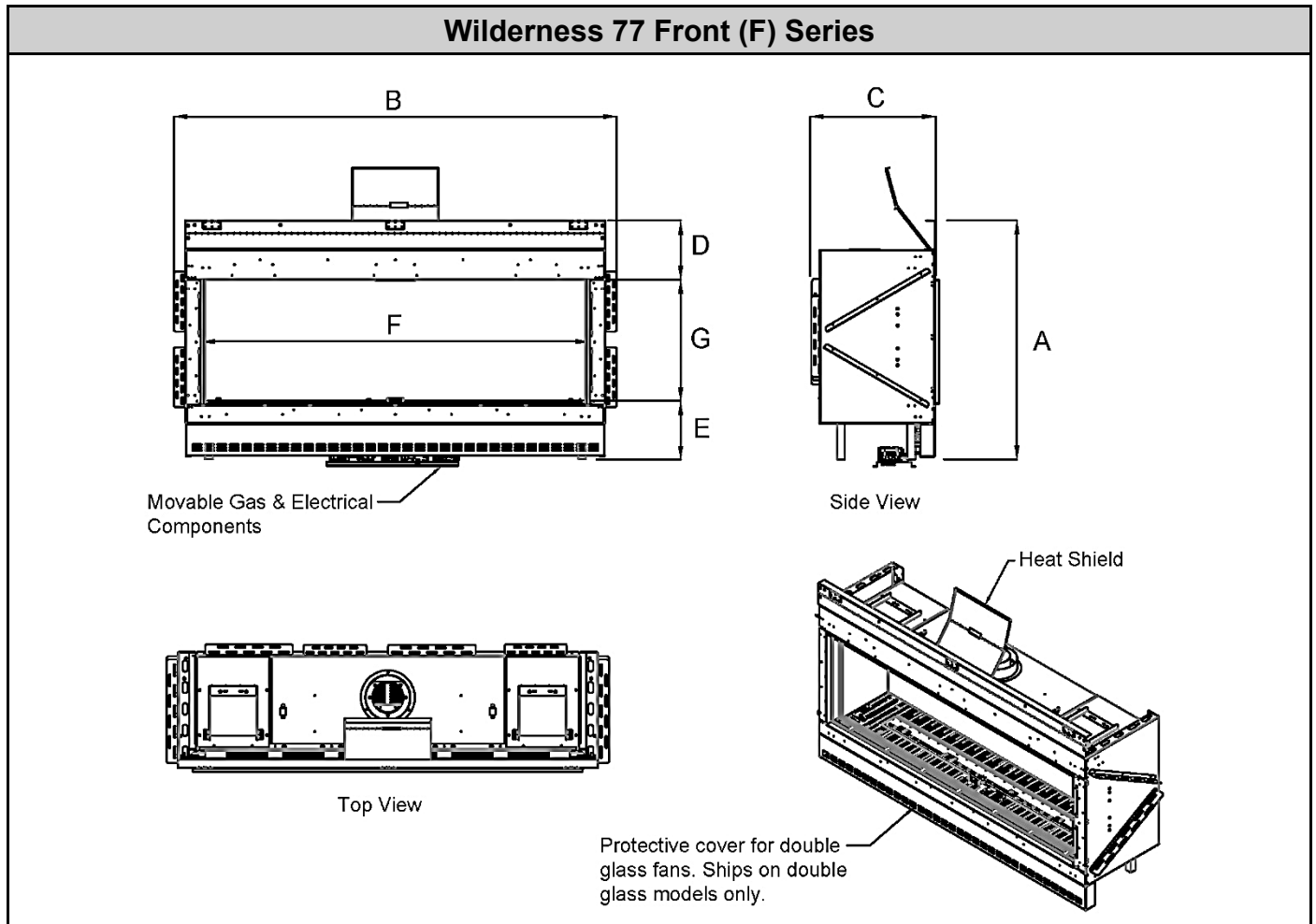

Fireplace	A: Height	B: Length	C: Depth	D: Stand-Off	E: Legs	F: Glass Length	G: Glass Height
77 F	35 3/4"	86 3/4"	21 5/8"	10 7/16"	9 5/8"	77 1/2"	15 3/4"

Framing	
Fireplace	77 F
A: Height	35 3/4"
B: Length	86 3/4"
C: Depth	21 5/8"
V: Firestop	Refer to pipe manufacturer's firestop dimensions

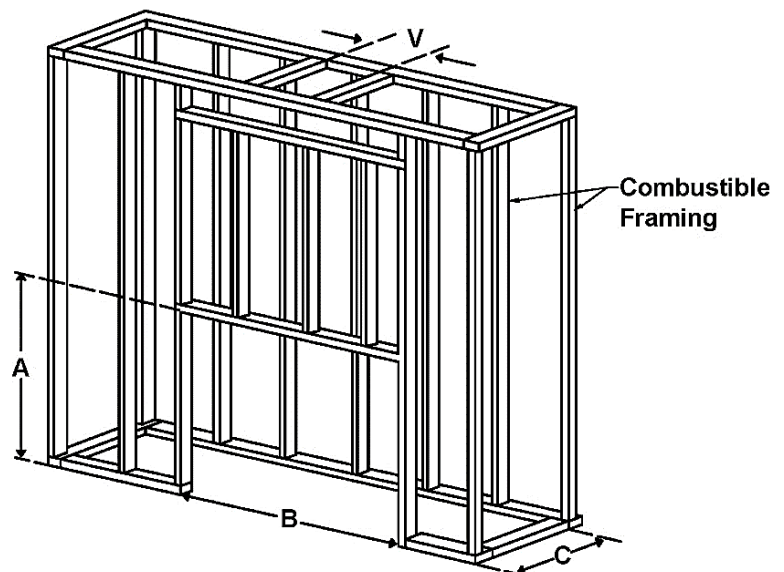

Wilderness 77 Corner (RS/LS) Series

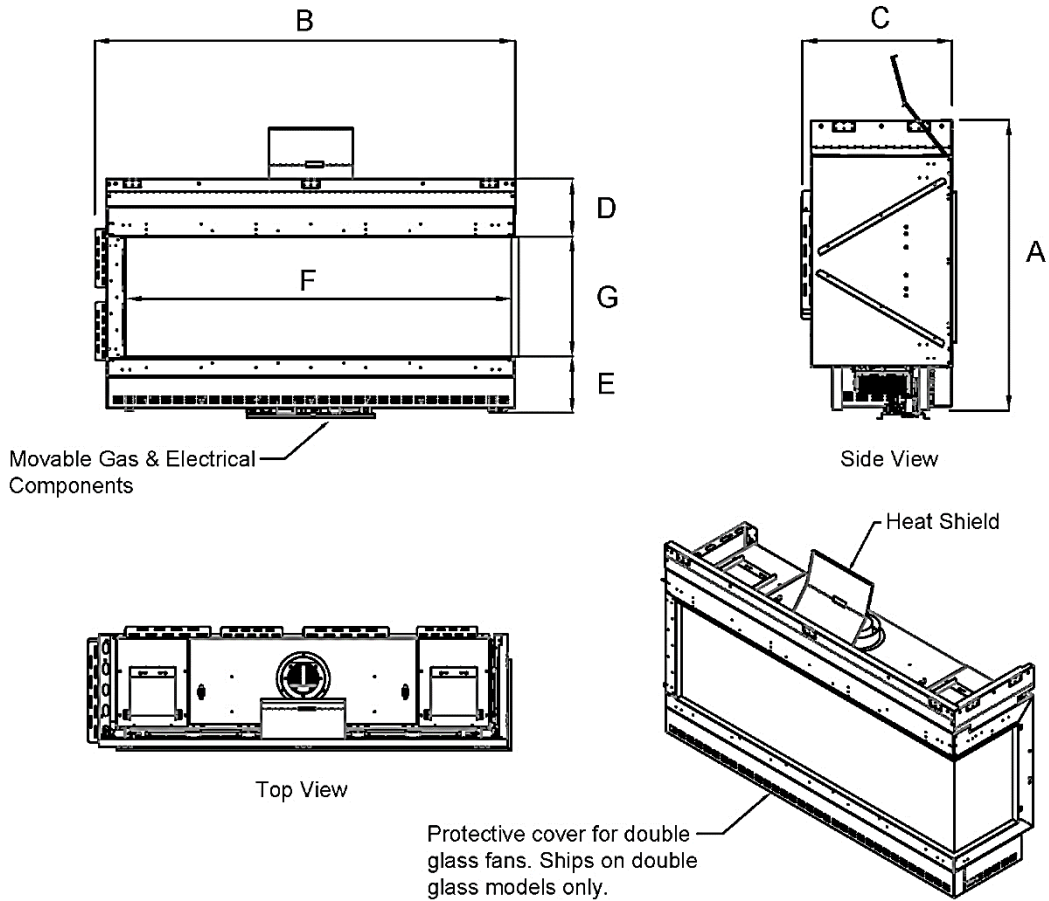

Fireplace	A: Height	B: Length	C: Depth	D: Stand-Off	E: Legs	F: Glass Length	G: Glass Height
77 RS/LS	35 3/4"	84 13/16"	21 5/8"	10 7/16"	9 5/8"	78 3/4"	15 3/4"

Framing	
Fireplace	77 RS/LS
A: Height	35 3/4"
B: Length	84 13/16"
C: Depth	21 5/8"
V: Firestop	Refer to pipe manufacturer's firestop dimensions

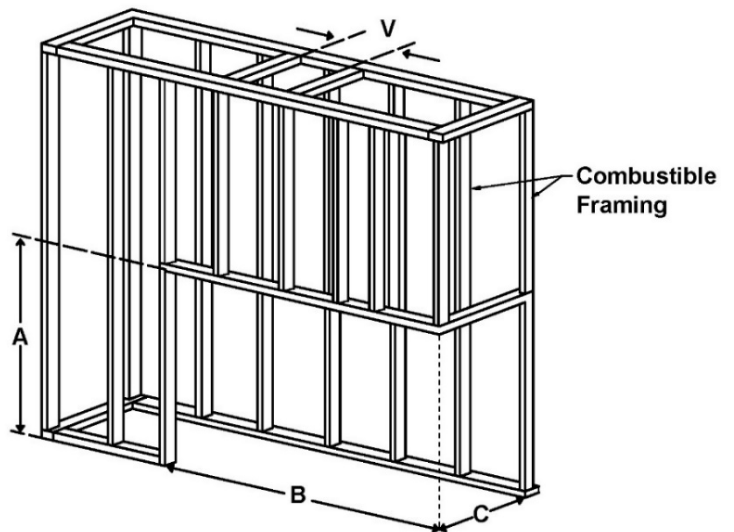

Wilderness 77 Three-Sided (TS) Series

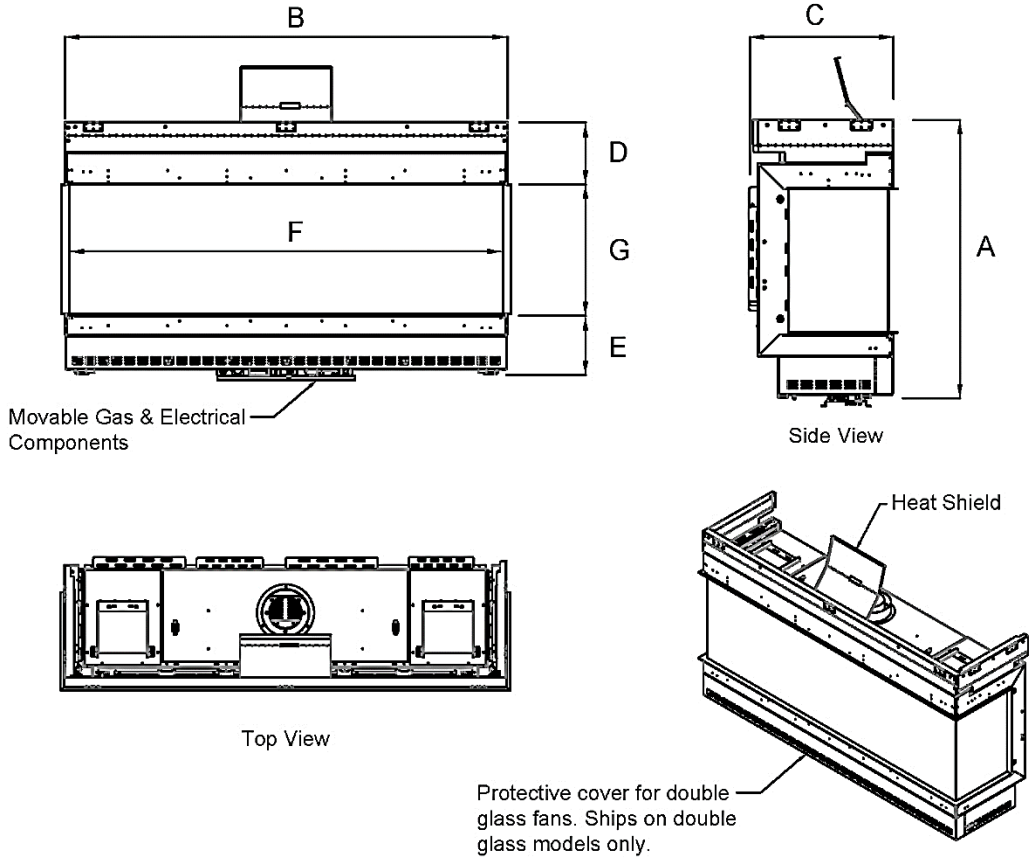

Fireplace	A: Height	B: Length	C: Depth	D: Stand-Off	E: Legs	F: Glass Length	G: Glass Height
77 TS	35 ³ / ₄ "	82 ³ / ₄ "	21 ⁵ / ₈ "	10 ⁷ / ₁₆ "	9 ⁵ / ₈ "	81 ⁵ / ₁₆ "	15 ³ / ₄ "

Framing	
Fireplace	77 TS
A: Height	35 ³ / ₄ "
B: Length	82 ³ / ₄ "
C: Depth	21 ⁵ / ₈ "
V: Firestop	Refer to pipe manufacturer's firestop dimensions

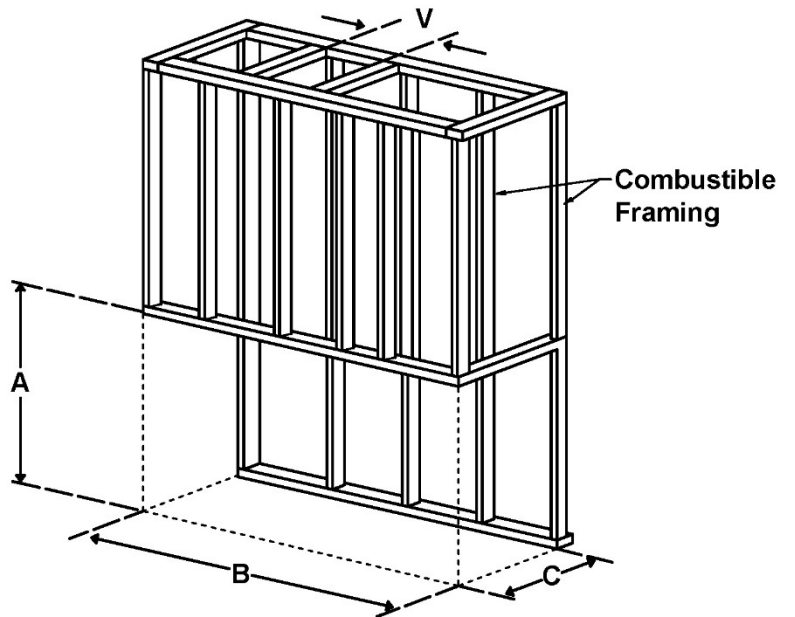

General Clearances

Viewing Area Clearance Zone

The viewing area clearance zone is an area that extends perpendicular from the fireplace viewing area. The depth of the viewing area clearance zone depends on the combustibility of the material in question. Distance is measured from the fireplace heat barrier.

Non-Combustible Materials	Must be minimum 12 inches from fireplace viewing area.
Combustible Materials	Must be minimum 16 inches from fireplace viewing area.

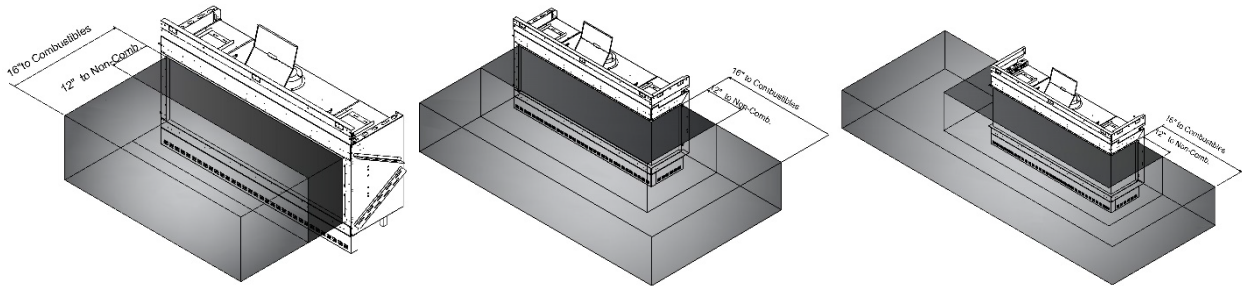

Materials (including combustible flooring and combustible finish material) are permitted below and around the viewing area clearance zone.

IMPORTANT NOTE: When placing material near the glass, take care to consider fireplace serviceability. It is strongly recommended that any items/materials placed in front of the front (long) glass be movable for easy access to the fireplace during servicing.

Clearance to a Side Wall

The fireplace viewing area is zero-clearance to a side wall. A side wall is defined as a wall that meets the viewing area at a 90° angle.

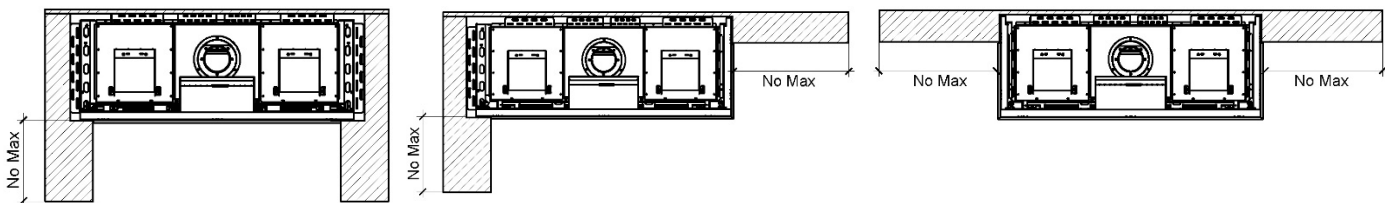

= Building Material

The temperature on the side wall can get as high as 150°F above ambient temperature. While the fireplace certification allows for this temperature variance, building and finish materials will have their own limitations. Consult the material manufacturer to ensure the material can safely withstand this temperature range.

This information does not apply to a wall that is constructed in front of the viewing area. For materials that will be in front of a main or side viewing area, please refer to the “Viewing Area Clearance Zone” section above.

Heat Release

A heat release is an opening in the fireplace chase that allows the heat inside the chase to passively circulate into an interior room. This heat is generated convectively as the fireplace heats up. It is separate from exhaust heat produced in the combustion chamber of the fireplace. For safety purposes, a **heat release is required** in order to keep the wall around the fireplace cool. Heat release requirements are the same for all 77 series models.

Heat Release Requirements

- The heat release must be located at or near the top of the fireplace chase and **start within** 6 inches (0-6 inches max) of the chase ceiling/firestop. It can start at the chase ceiling. It can be located on the front, sides or back of the chase. It can be released into any interior space that shares a wall with the chase.
- Minimum heat release size requirement depends on heat release orientation:

Fireplace Series	Horizontal Heat Release	Vertical Heat Release
Wilderness 77	Minimum 200 sq. in. of free air space	Minimum 260 sq. in. of free air space

- For horizontal heat releases only, the height of the heat release must not exceed 1/3 of the width or it will be considered a vertical heat release requiring a larger sq in space.
- The space the heat release vents into must have a minimum volume of 184 ft³.
- The heat release can be in the form of (but not limited to) a louvered ventilation grille, gap, or reveal.
 - For louvered/perforated ventilation grilles, the net free air space allowed in the louvered area must be equal or greater than the minimum number of square inches required per fireplace.
- The interior area of the narrowest part of the fireplace chase (in square inches) must never be less than your required heat release size (see “Chase Area Minimum” section for details).
- The heat release cannot be vented outdoors or to an unconditioned space.

The following diagrams are examples of potential heat release options. These drawings serve as illustrative purposes only.

Horizontal Heat Release

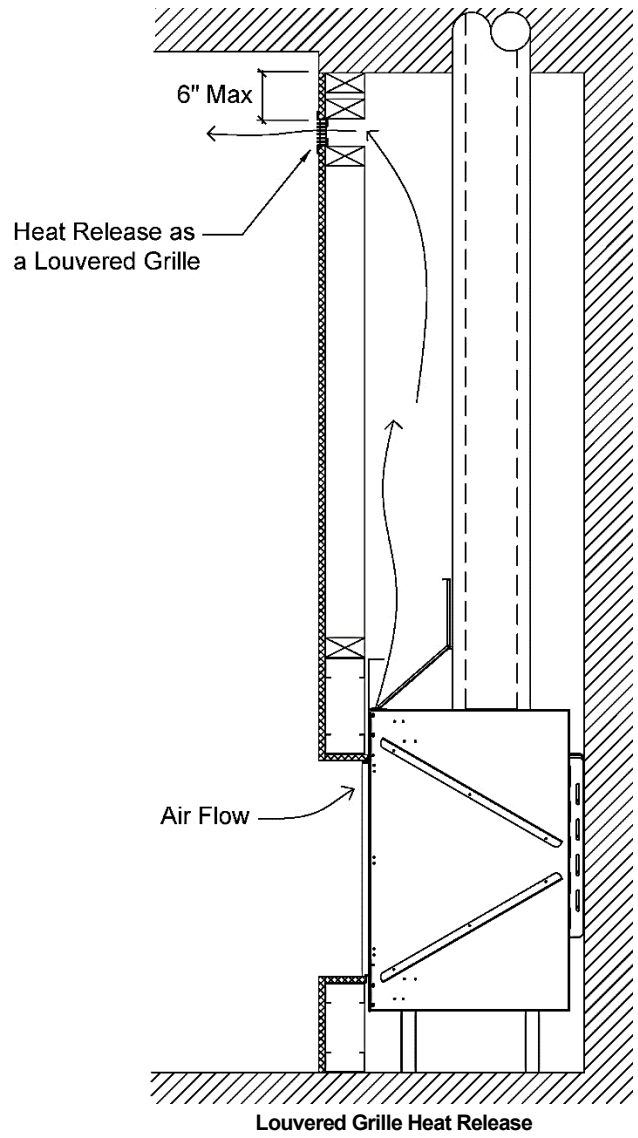
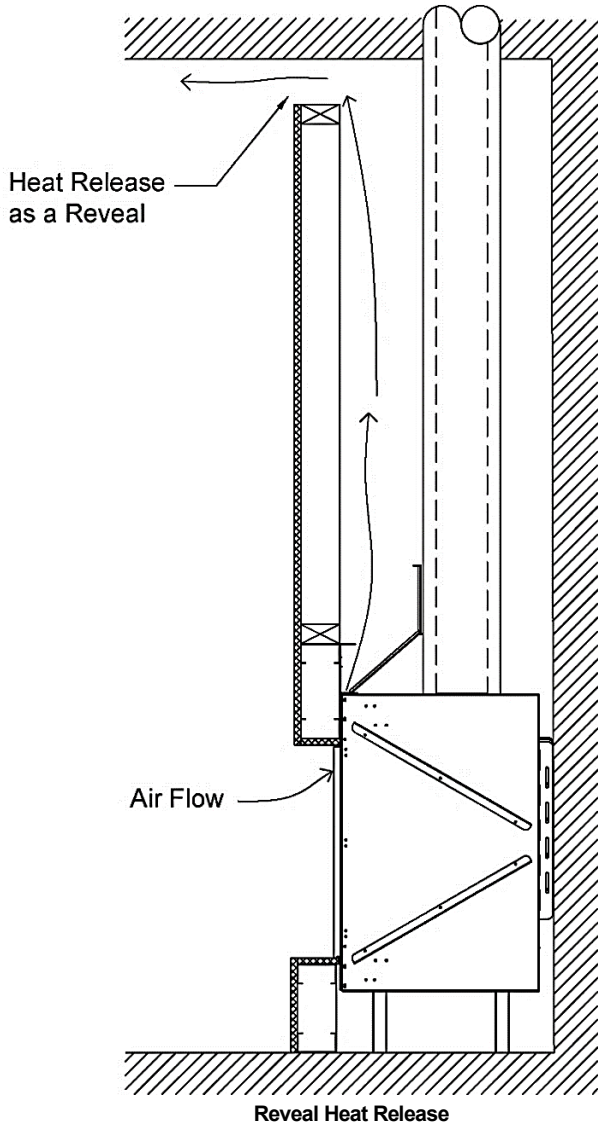

Vertical Heat Release: Split Front

The heat release is oriented vertically and split between the two sides of the chase.

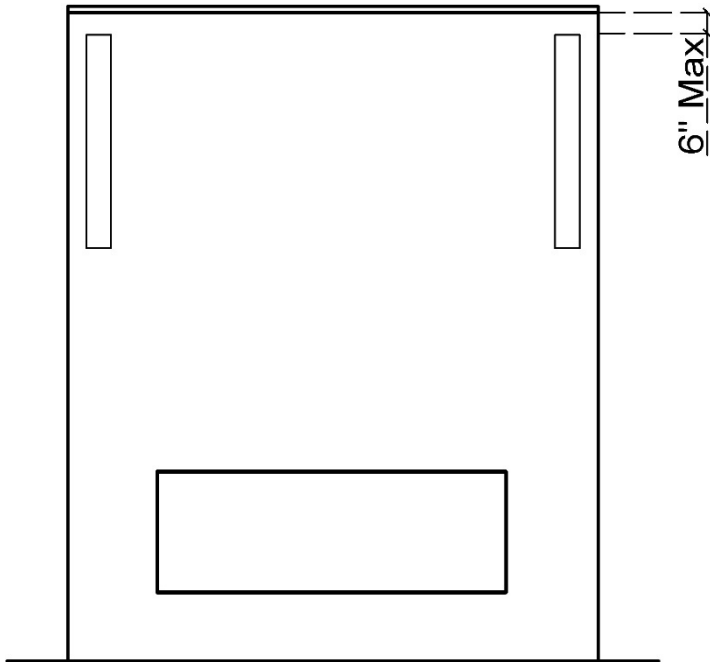

Split Front Vertical Heat Release

Vertical Heat Release: Full Side

The heat release is oriented vertically. Entire heat release is on one side of the fireplace chase.

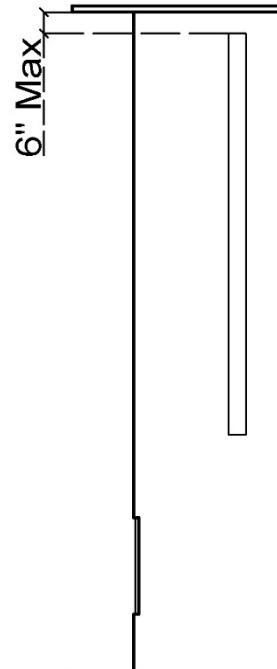

Full Vertical Heat Release on One Side

Sprinkler Clearance to Heat Release

In a situation where a sprinkler head is near the heat release, the sprinkler head must be minimum **24 inches** (linear length) from the heat release opening.

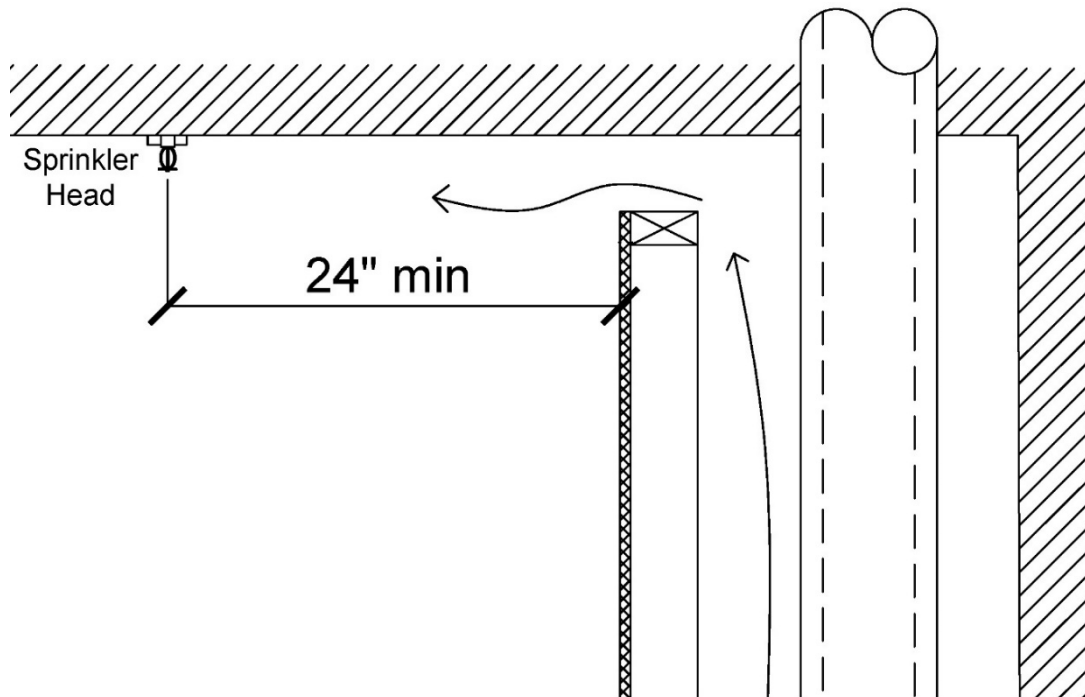

Air Intake Opening

For fireplaces with a double glass heat barrier only, an air intake opening must be incorporated into the framing and finish around the fireplace. The air intake opening is essential to maintain cool air flow between the double glass panels by allowing the double glass fans to circulate room air through the glass panels and up into the chase. The opening must meet the minimum size requirement, as stated in the table below.

Fireplace Series	Air Intake Opening Size
Wilderness 77	Minimum 200 sq. in. of free air space

The air intake opening can be finished in the form of a louvered ventilation grille, gap, or toe-kick (reveal). For louvered ventilation grilles, the net free air space allowed in the louvered area must be equal or greater than the minimum number of square inches required per fireplace.

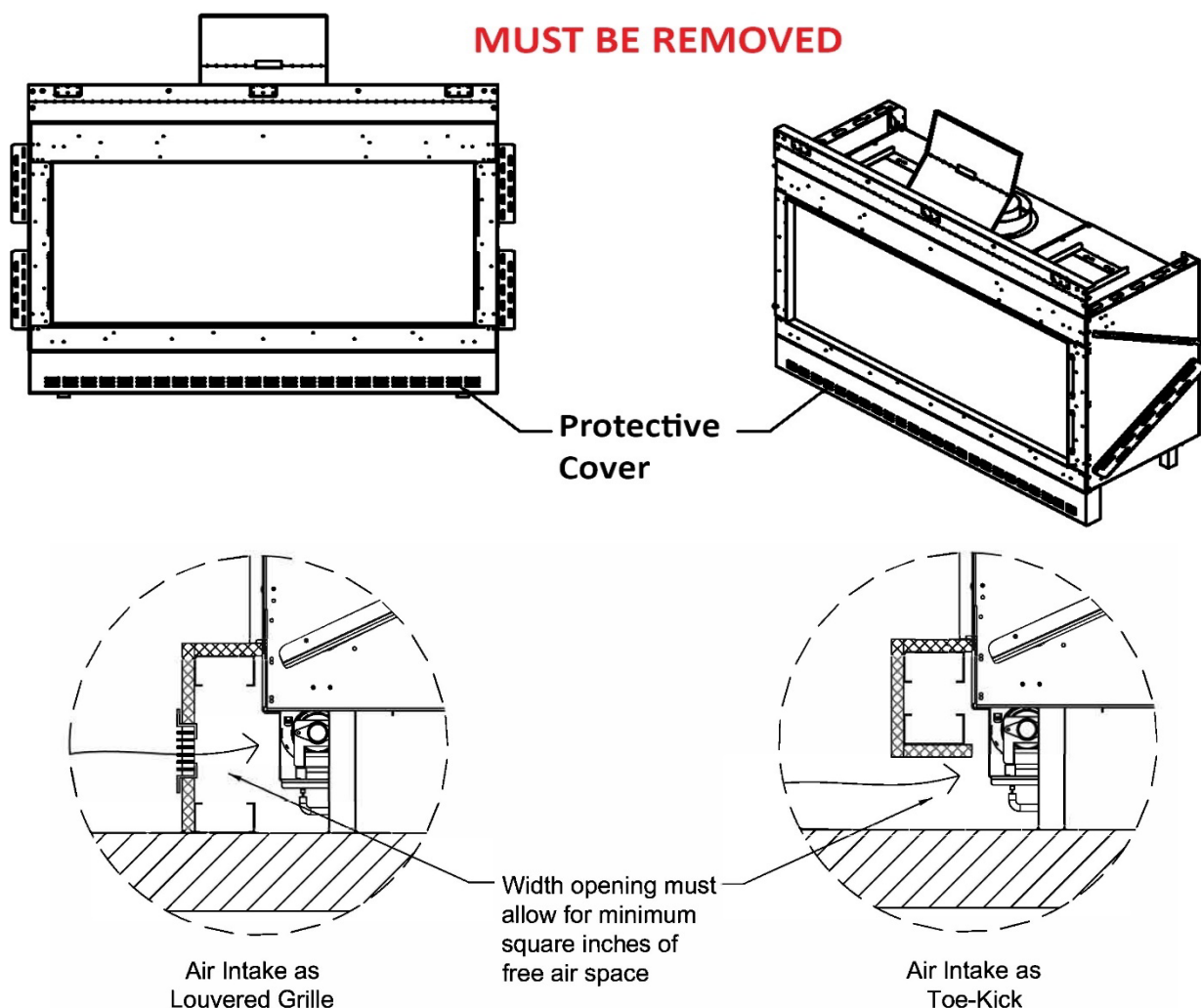

The entire air intake opening must be located at or below the level of the double glass fans. The air intake is not required to be on the front wall of the fireplace. The air intake cannot be on a wall that allows air from outside the house directly into the fireplace chase. Air must be from a conditioned space.

Air flow must be able to get to the double glass fans by removing the protective cover after the unit is set into place.

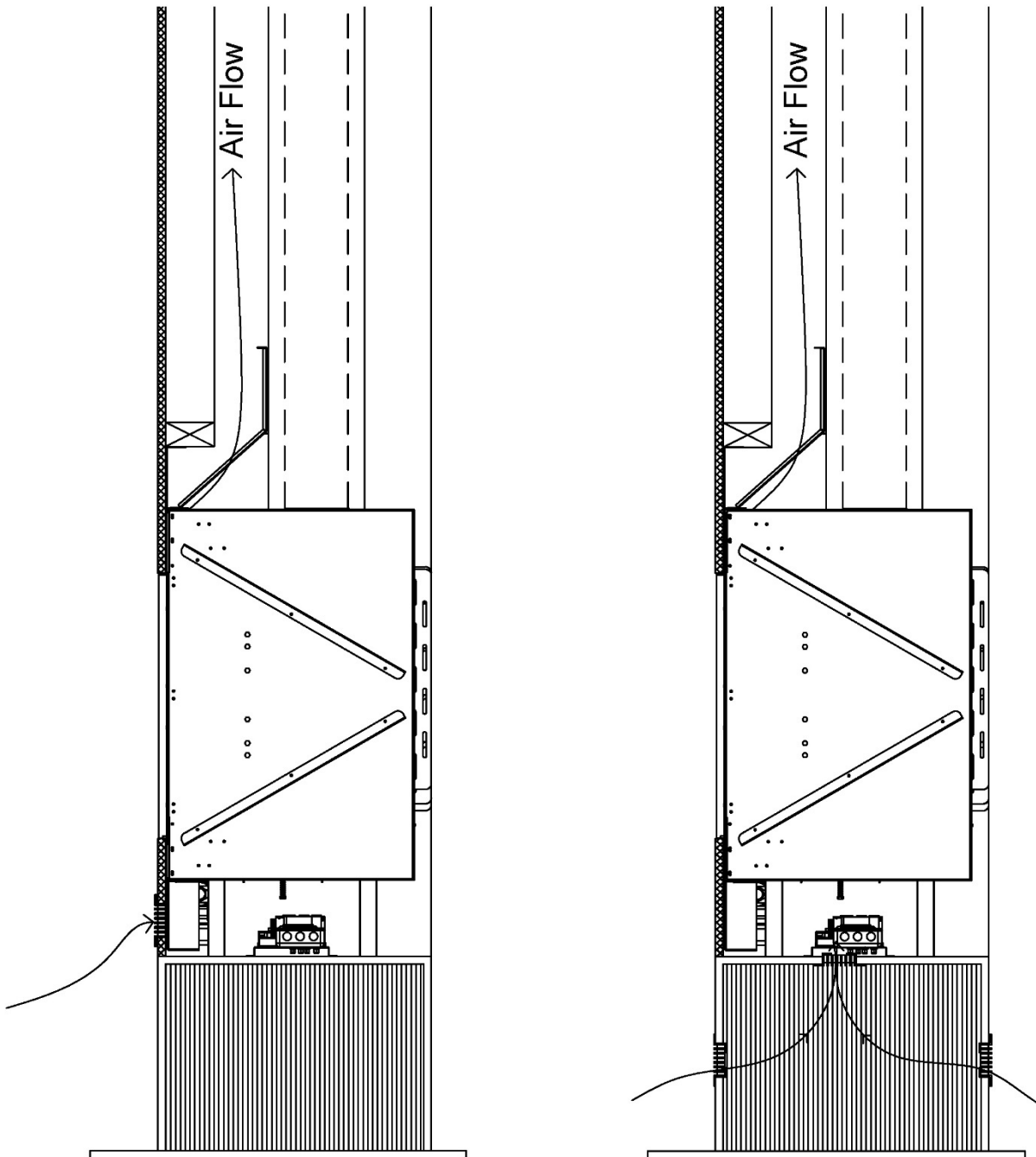

Air Intake for a Platform



LEGEND	
	5/8" Type X Drywall
	Combustible Framing

 NOTE: Please refer to the "Chase Floor/Platform" section for details on platform construction.

Mounting a TV/Artwork

Ortal's Cool Wall Technology is engineering that reduces the convective heat from the fireplace and prevents heat buildup inside the fireplace chase, mitigating any damage that may result from the wall reaching high temperatures. Ortal's Cool Wall system provides the option of safely installing artwork, a TV, or other similar electronic components above the fireplace by reducing the wall temperature above the fireplace.

Location	Wall Temperature
0-6 inches above fireplace	100°F - 120°F
6-12 inches above fireplace	90°F - 100°F
12 inches above fireplace	80°F - 90°F

Maintain the following general requirements to mount a TV or artwork above the fireplace and prevent heat damage:

- Mount the TV or artwork at the minimum clearance above the top of the fireplace viewing area. Minimum clearance amount depends on flush or recessed installation. See sections below for more information.
- Wires inside the chase are not permitted to cross over the fireplace. Wires must be installed against a wall.

The decision to install a television above an Ortal fireplace is up to the discretion of the owner. TV and art manufacturers may specify that their product should not be installed on, near or above a heat source. Ortal will not be held liable for any adverse effects on a TV, artwork or other equipment located near the Ortal fireplace. It is the owner's responsibility to verify that their TV or artwork can withstand the wall temperatures as outlined in the above wall temperature chart.

The following diagrams can be used as a guide for customers who do decide to locate their TV and artwork above their Ortal fireplace. These drawings illustrate ways of reducing the amount of heat impact to the area surrounding the fireplace.

Flush Mounted TV/Artwork

When the TV is mounted on a wall that is flush to the fireplace, the TV must be at least **4 inches** from the top of the fireplace glass viewing area. Ensure all clearances are maintained. See diagram below for details.

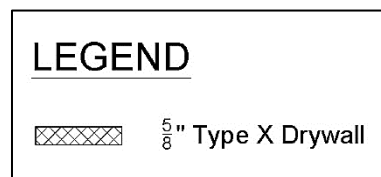
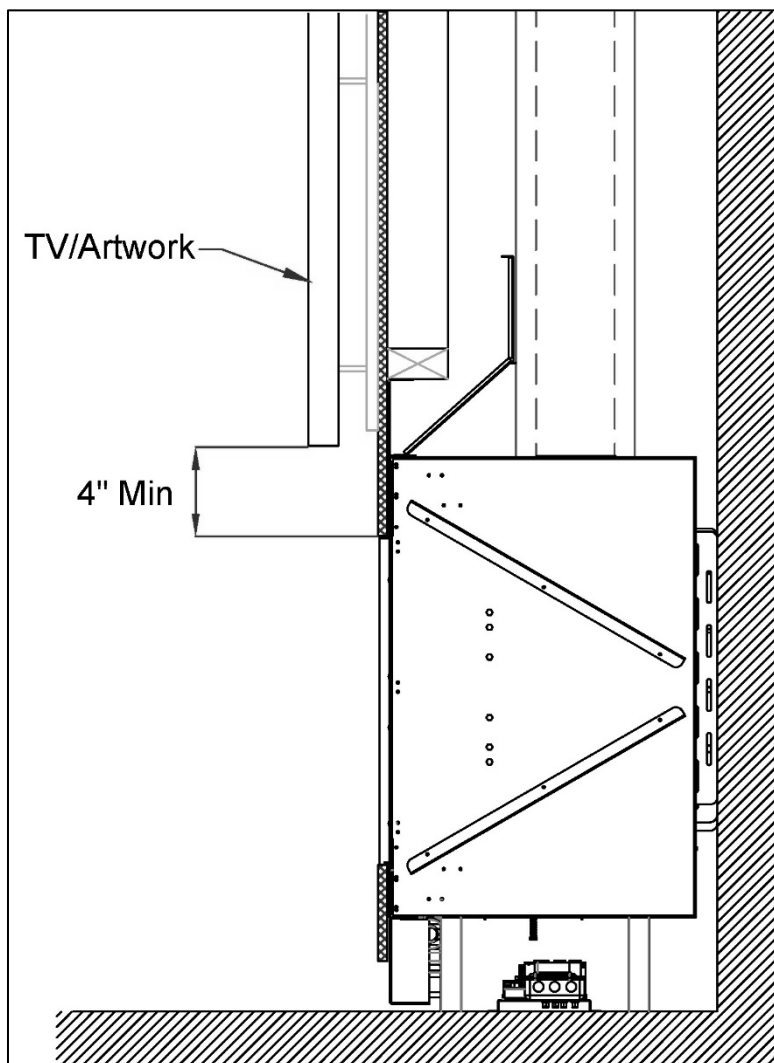

Recessed TV/Artwork

When the TV is mounted on a wall that recesses over the fireplace, the TV must be at least **12 inches** from the top of the fireplace glass viewing area.

At 12 inches above the fireplace viewing area, maximum possible recess is 5 inches. A deeper recess will interfere with required clearances to venting. When higher than 12 inches above the fireplace viewing area, the maximum possible recess depth may be larger if venting is offset as shown in diagram below.

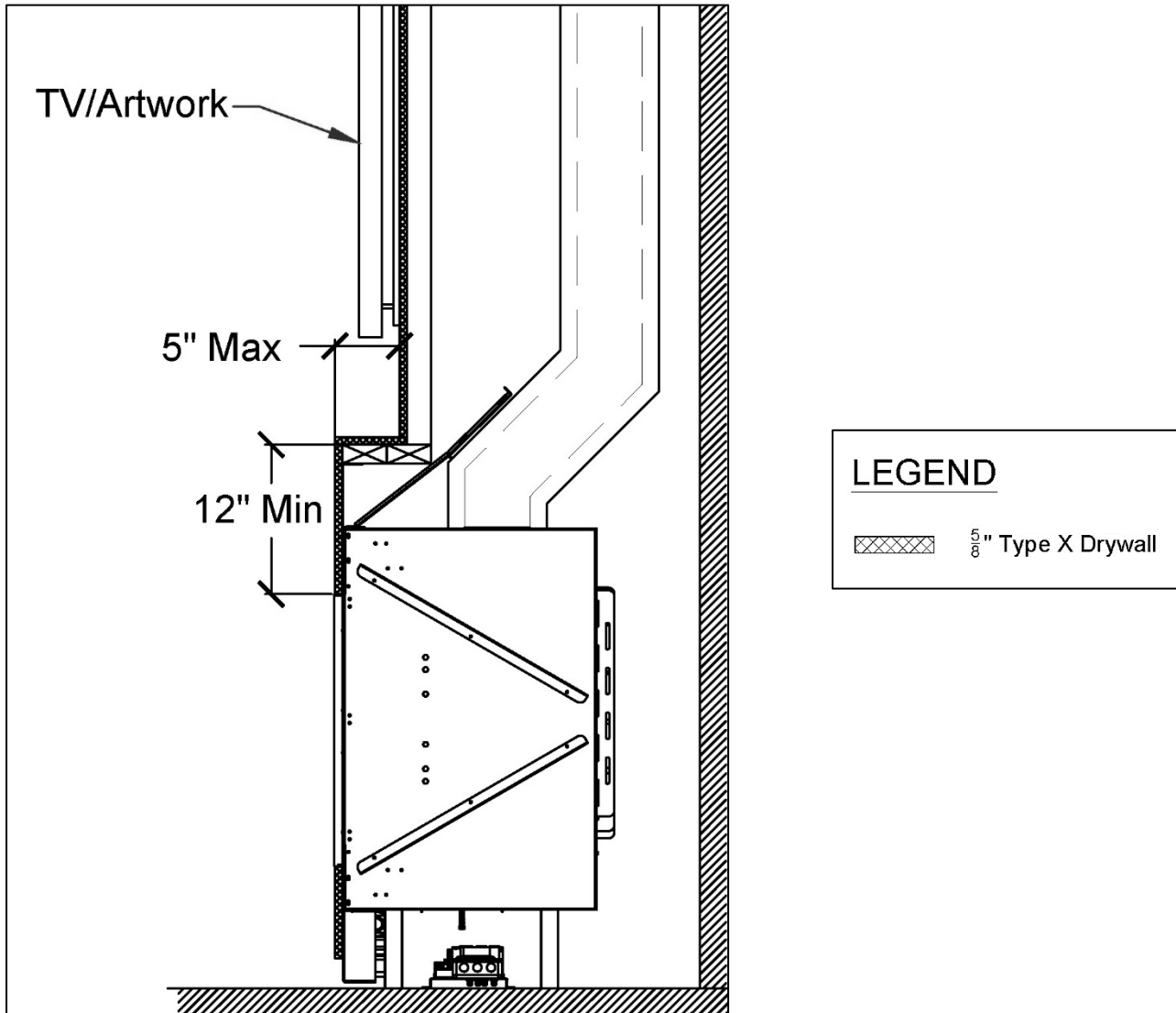

NOTE: Vent clearances must be maintained. See "Vent Clearances" section for details.

Access Area Requirements

An access panel, or some other form of clear access, is required at each of the following two locations for servicing purposes:

- Power Vent Control Box
- Power Vent Fan Box

Prior to installation, fireplace dealers/installers should work with the owner, builder, project architects and/or interior designers to determine the best size and location of their access panel depending on project design needs.

Power Vent Control Box Access Area

Location

The Power Vent Control Box is connected to the rest of the fireplace's gas and electrical components at the fireplace. These components are movable and can be located within **36 inches of the pilot** to the side or back of the fireplace (see "Routing the Gas Line" section).

For double glass models, see "Protective Cover for Double Glass Fans" section below.

Size

Minimum recommended access area/panel size is **12 inches x 12 inches**. If there is any distance between the access area and the power vent control box, the access panel size must be increased accordingly. Access area size and location may also need to increase depending on the needs of the project and design around the fireplace. In all cases, the access panel must allow a technician to comfortably access and service the fireplace's gas and electrical components.

Power Vent Fan Box Access Area

Location

The access area for the power vent fan box must allow for easy access to the **service door** on the power vent fan box.

Size

Minimum recommended access area/panel size is **18 inches x 18 inches**. If there is any distance between the access area and the power vent fan box, the access panel size must be increased accordingly. Access area size and location may also need to increase depending on the needs of the project and design around the fireplace. In all cases, the access panel must allow a technician to comfortably access and service the fireplace's gas and electrical components.

NOTE: The terms "access panel" and "access area" are used interchangeably in this manual. An access panel is the most common form of access, but the access area (required at both the fireplace and the power vent) is not required to be in the form of a panel.

Protective Cover for Double Glass Fans

Fireplaces with a double glass heat barrier come equipped with a protective cover to protect the fans from damage. When installed, this protective cover blocks service access to gas and electrical components. The protective cover is installed under the front and sides of the fireplace.

The protective cover must be removed when the fireplace is set into positioning.

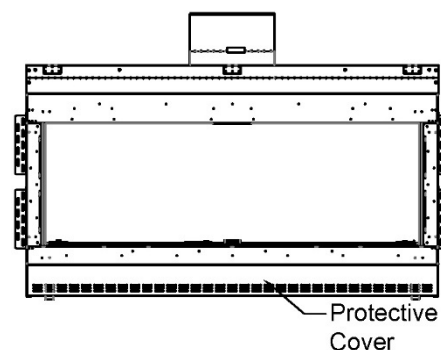

Chase Area Minimum

To ensure the convective heat within the chase passively moves to the heat release at an optimal rate, all parts of the interior of the chase must at least the same size as the fireplace heat release (see "Heat Release" section to determine your model's required heat release size) at size at any given point. To determine if your chase meets this requirement, use the following equation at the narrowest part of the chase.

$$\text{Chase Area} = (\text{Chase Length} \times \text{Chase Depth}) - (\text{Area of the Pipe})$$

Area of the Pipe:

5"x8" venting = 50.27 in²

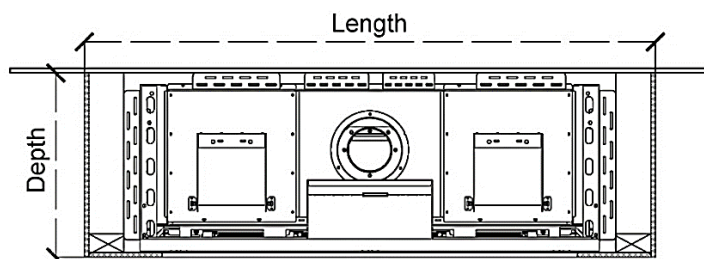

Fireplace Chase (Top View)

If the heat release is split into 25/75 portions due to an oversized ledge, the chase only needs to be the size of 75% of the heat release because 25% of the heat is already being released at the ledge (see "Recessed Ledge Detail" section for details).

Recessed Ledge Detail

A ledge over the top of a fireplace that is less than 24 inches from the top of the fireplace viewing area must maintain a minimum of **12 inches from the top of the viewing area to the top of the framing**. **Entire structure must be non-combustible (framing and finish).**

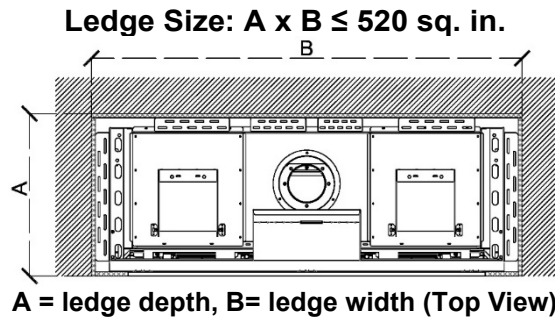

Oversized Ledge

If ledge surface area exceeds the values shown in the chart above, the heat release must be divided between the ledge and the chase ceiling.

! **NOTE:** Chase area minimum requirements must be met throughout the entire fireplace chase. See “Chase Area Minimum” section or details.

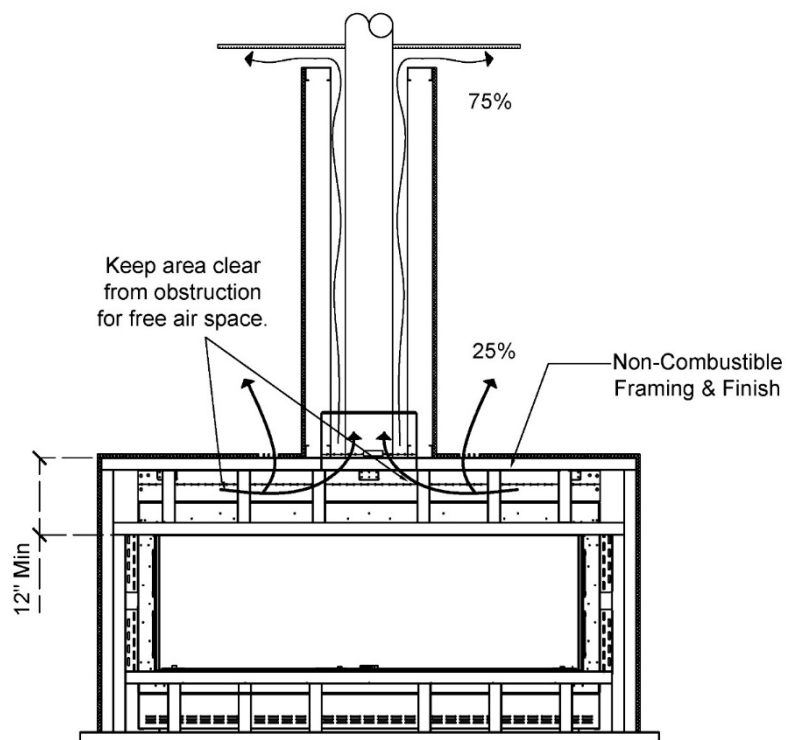

Structural Weight Support

The fireplace must not carry any structural weight. The framing must be supported by another surface. Consult with the project structural engineer and refer to your local building codes for proper wall support.

The following drawing shows a recommended approach to this type of installation. Please note that these drawings are not to scale. All fireplace drawings with correct dimensions are available on the Ortol website.

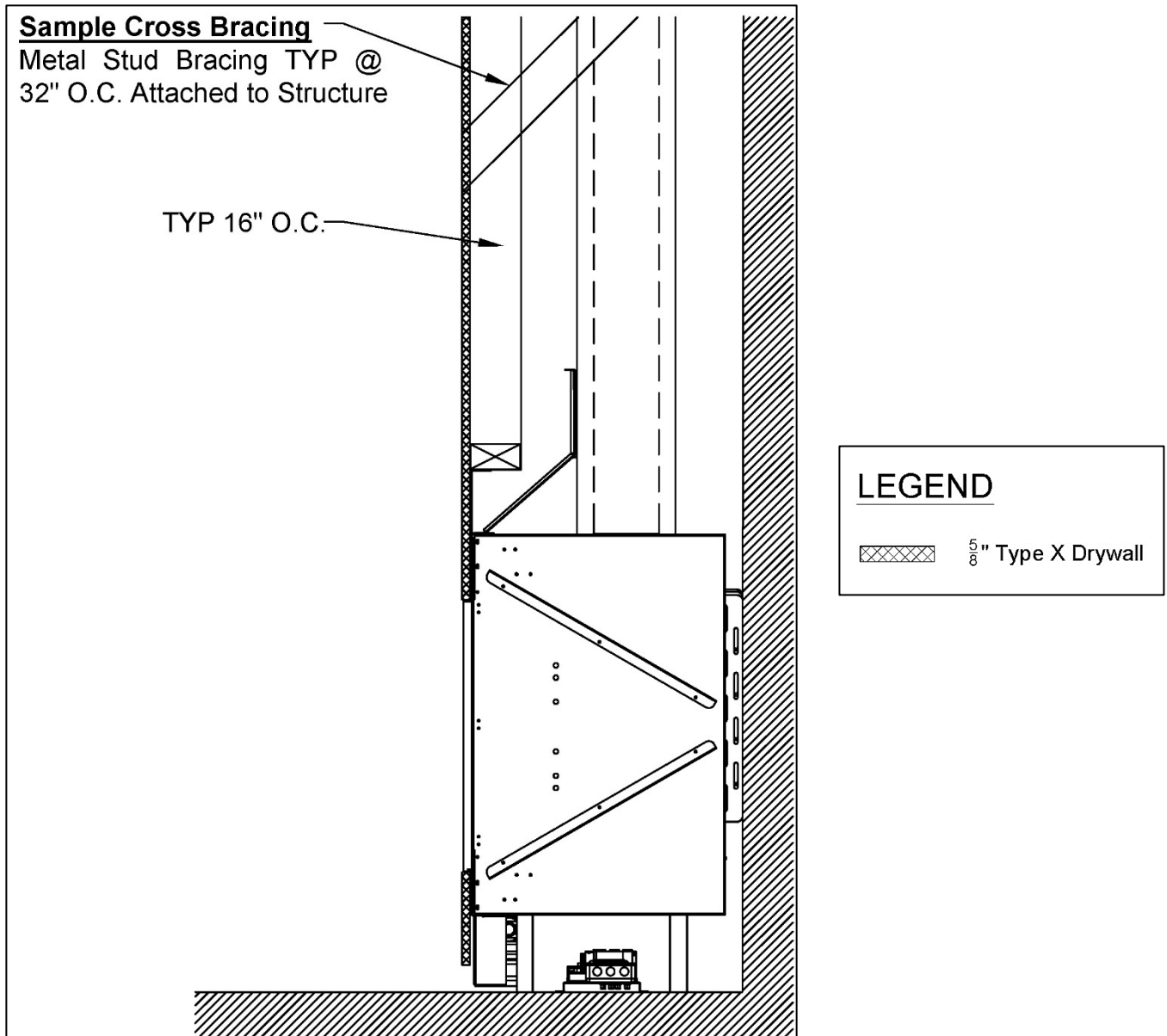

Finishing

The following diagrams show various finished applications. **Diagrams apply to both combustible and non-combustible finishing material.**

! IMPORTANT NOTES:

- All recessed installations must comply with applicable maximum overhang limit and side wall clearances. See “→Maximum Overhang/Mantel Depth” and “Clearance to a Side Wall” sections for details.
- No material is permitted to extend past the metal lip surrounding the fireplace viewing area. This area must be unobstructed to allow the heat barrier and inside glass panel to be removable.



! WARNING: Wood finish or floor/hearth extension may dry out, crack, warp or become discolored over time. Consult with floor manufacturer for required clearances to a heat source.

Flush Installation

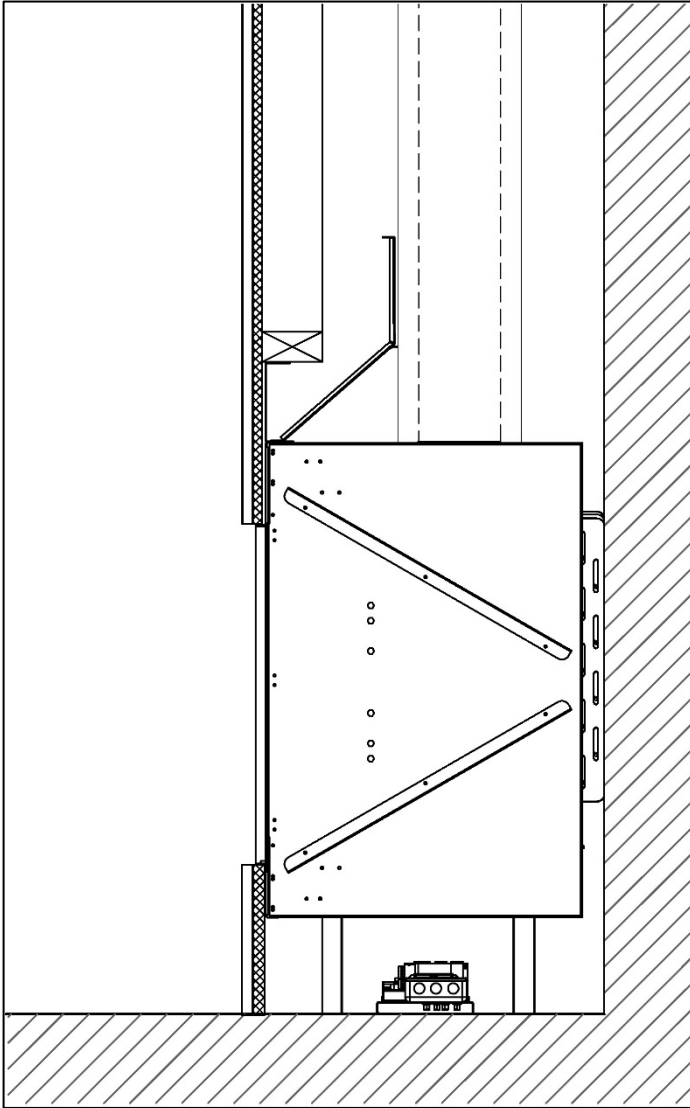
Diagram applies to both combustible and non-combustible finish material.



LEGEND

	5/8" Type X Drywall
	Finish

Recessed Installation

Diagram applies to both combustible and non-combustible finish material. The finish must maintain at least a 1/8" clearance to the fireplace to both the top and bottom recesses.

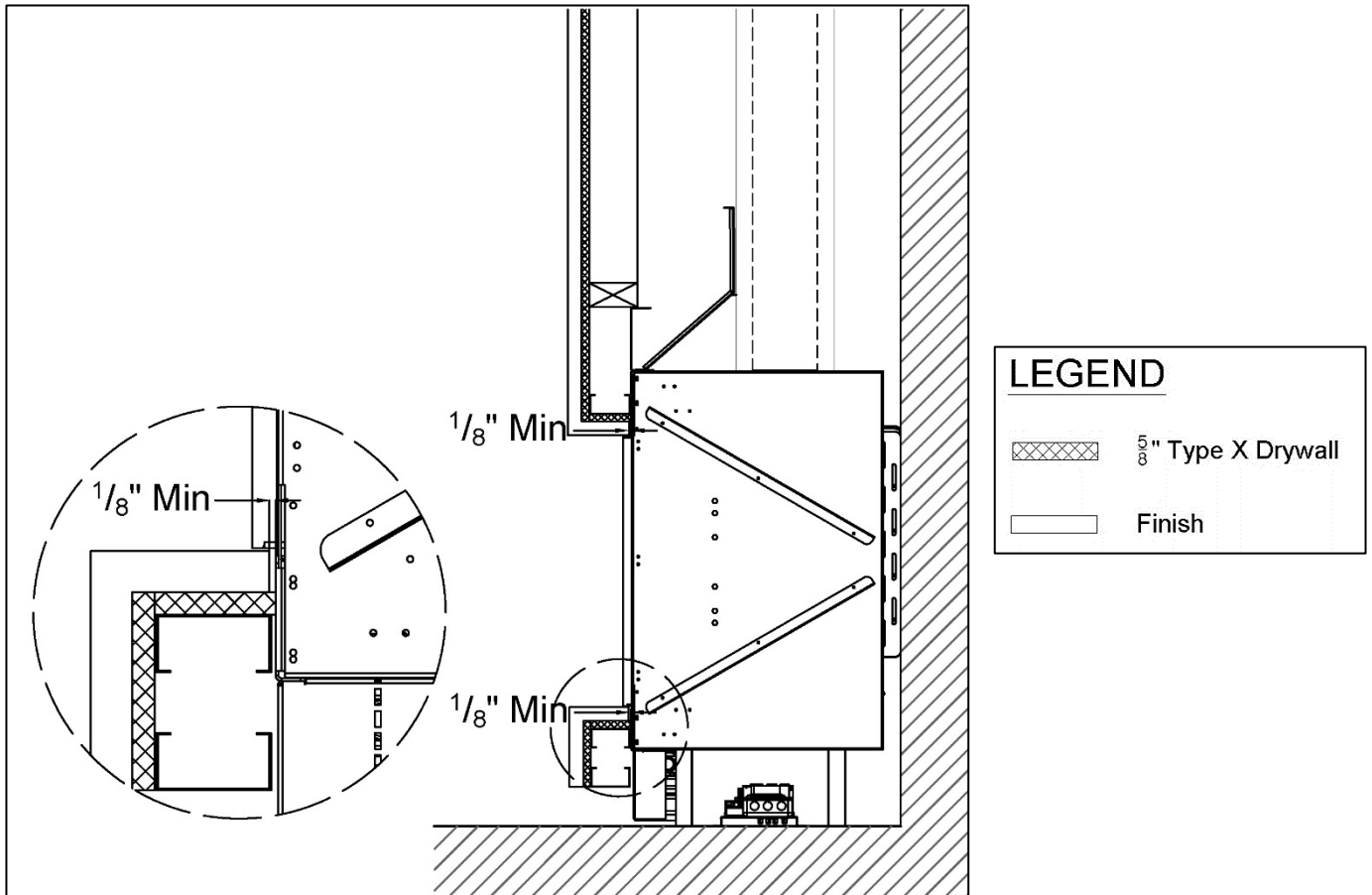

Maximum Overhang/Mantel Depth

Overhang (aka Mantel) depth of a recessed fireplace must not exceed **12 inches**. Overhang depth is measured from the edge of the fireplace lip to the out-most part of the wall (including finish material). **Side overhang has no limit**. Finishing material on the underside of the overhang can be combustible or non-combustible. **Metal studs must be used for framing overhangs**.

Bottom recess (or "hearth extension") has no minimum or maximum depth requirement. If bottom recess depth exceeds 12 inches, ensure the structure is capable of supporting the weight of a fireplace technician for servicing.

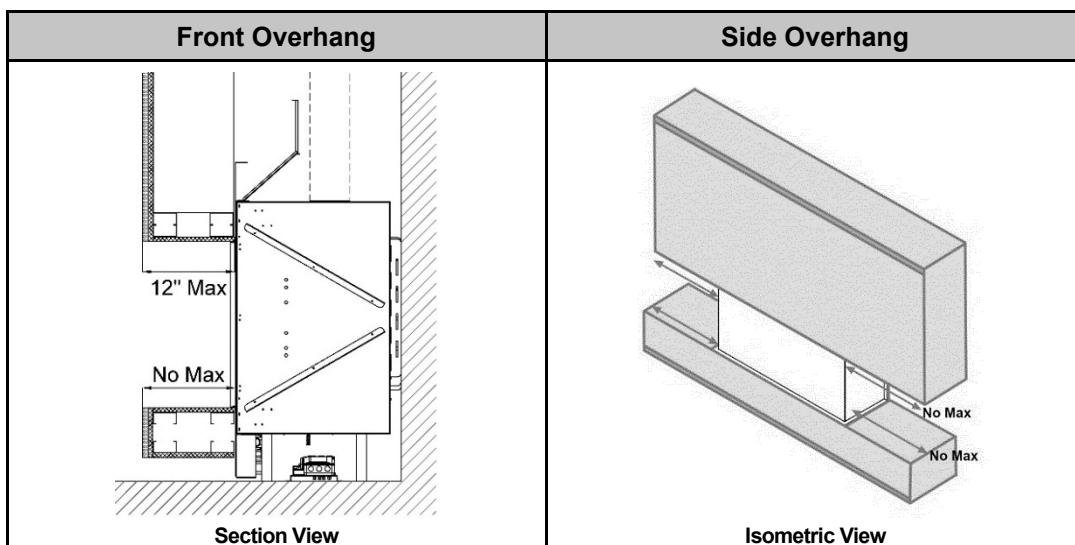

Venting

The Power Vent Max System (or equivalent Energex RS System) is required for use with the Wilderness 77 Series fireplaces.

Power Vent Max System

Ortal's Power Vent Max is a proprietary direct vent power vent system that sits in-line with the 5"x8" co-axial vent pipe. This system is comprised of a double-blower power vent fan box, control box, and pressure monitoring components. The power vent fans create a draw on the exhaust, forcing the flow through the inner pipe. This creates a suction of fresh air that enters and draws in through the outer air intake pipe.

There are two Power Vent Max product options: the **Inline Power Vent Max** and the **Horizontal End-Line Power Vent Max**. The installation and clearance requirements of both products are detailed in this manual. Follow only the instructions that apply to your chosen product. Power Vent Max dBA level is 53.

Inline Power Vent Max

The Power Vent Max is required for use with the Wilderness 77 Series fireplaces. Under the few circumstances where the Ortal Power Vent Max might not be the perfect fit, the Energex RS Series Power Vent System can be substituted. For information on the Energex RS Series Power Vent System, please refer to the Ortal Energex RS Power Vent manual.

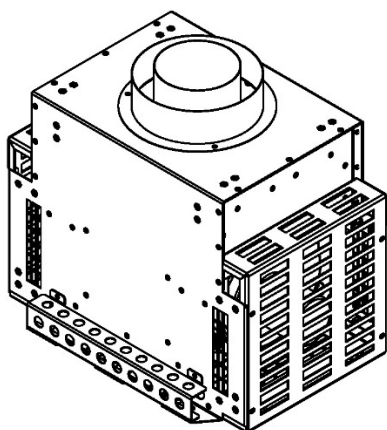

Inline Power Vent Max Fan Box

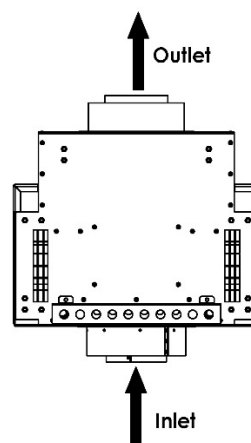

Power Vent Air Flow

Pre-installation Considerations

Before you begin installation of the Ortal Power Vent Max, ensure you have planned for the following:

- Termination location (see "Vent Termination" section for details)
- Electrical requirements (see "Electrical" section for details)
- Local codes and regulations
- Power vent and vent pipe clearance requirements (see "→Inline Power Vent Max Clearances" and "Vent Clearances" section for details)
- Power vent access location (near the power vent)
- Total venting run length and number of elbows (see all sections under "Venting Requirements" section for details)
- Power Vent Max must be at minimum 8 feet from the fireplace.

IMPORTANT: Read Before You Begin

Access Areas are required at the power vent service door in following locations for servicing:

- At the power vent fan box. Access area must be min. 18"x18".
- At the power vent control box near the fireplace. Access area must be min. 12"x12".

If there is any distance between the access panel and the power vent, the access panel size must be increased accordingly.

Airflow Requirement: To keep the component operating temperature cool, the power vent must be located in an area with a **min. 35 cubic feet** of air space AND have an air intake that allows **min. 100 square inches** of net free air space.

It is recommended to use a louvered access panel (used for servicing the power vent) that meets the min. 100 square inches of net free air space requirement.

Vent Installation: For vent component installation instructions, refer to manufactures instructions for gas appliances.

Review all clearance and venting requirements, pre-installation considerations for both the venting and the Power Vent Max, and local code before beginning installation.

Ensure all materials, system components, and tools necessary are present, and in good condition at the time of installation.

Venting may be installed independently of the fireplace and power vent fan if needed, as site conditions permit.

Inline Power Ven Max Installation Instructions

Step 1: Install the Control Box

1. Place control box near the minimum 12"x12" control box access panel.

 **WARNING:** To avoid operational malfunctions, control box must be oriented with "This Side Up" wording facing up and the feet facing down.



Step 2: Install the Power Vent

2. Orient the power vent according to vent pipe's intended exhaust inlet and outlet location.

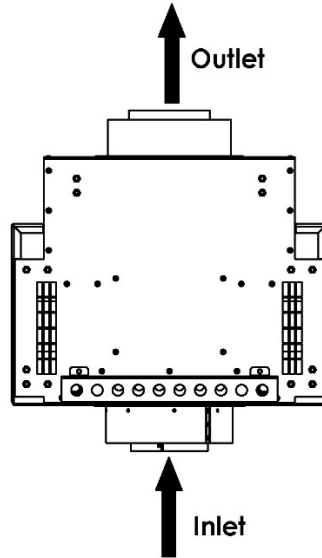

Inline Power Vent Max, Exhaust Inlet & Outlet

3. At the desired location, secure the power vent to a stable structure using the nailing flanges on the power vent box. Stable structure may be combustible or non-combustible. Ensure clearances are maintained.
4. Install venting components leading from the fireplace to intended location of the power vent.
5. Attach venting pipe to exhaust inlet on the power vent.
6. At the exhaust outlet, install remaining venting components leading to the termination cap.

 **REMINDER:** The power vent should be installed within close proximity of power vent access panel. If there is any distance between the access panel and the power vent, the access panel size must be increased accordingly.

Step 3: Connect the Power Vent to the Control Box

7. Insert the pig-tailed end of the 62-foot power cable (supplied) to the power vent **control box** through the cable clamp.
8. Open the power vent service door and connect the cable's pig-tailed end to the pig tail located in the **power vent**. Make sure all connections are tight and secure.
9. Plug the control box into the outlet inside the access panel area as per the Ortol fireplace installation instructions. See "Electrical" section for details.

NOTES:

- Electrical connections should be completed by a certified electrician, and in accordance with local building codes.
- A protective layer of grease is used in the manufacturing process of the venting. The heat burns away this grease and can cause some smoking and smell during the initial running, which should dissipate within the first few hours of use.

 **WARNING:** This smoke could set off a fire alarm. Anyone with an integrated smoke alarm system needs to be aware.

Inline Power Vent Max Dimensions

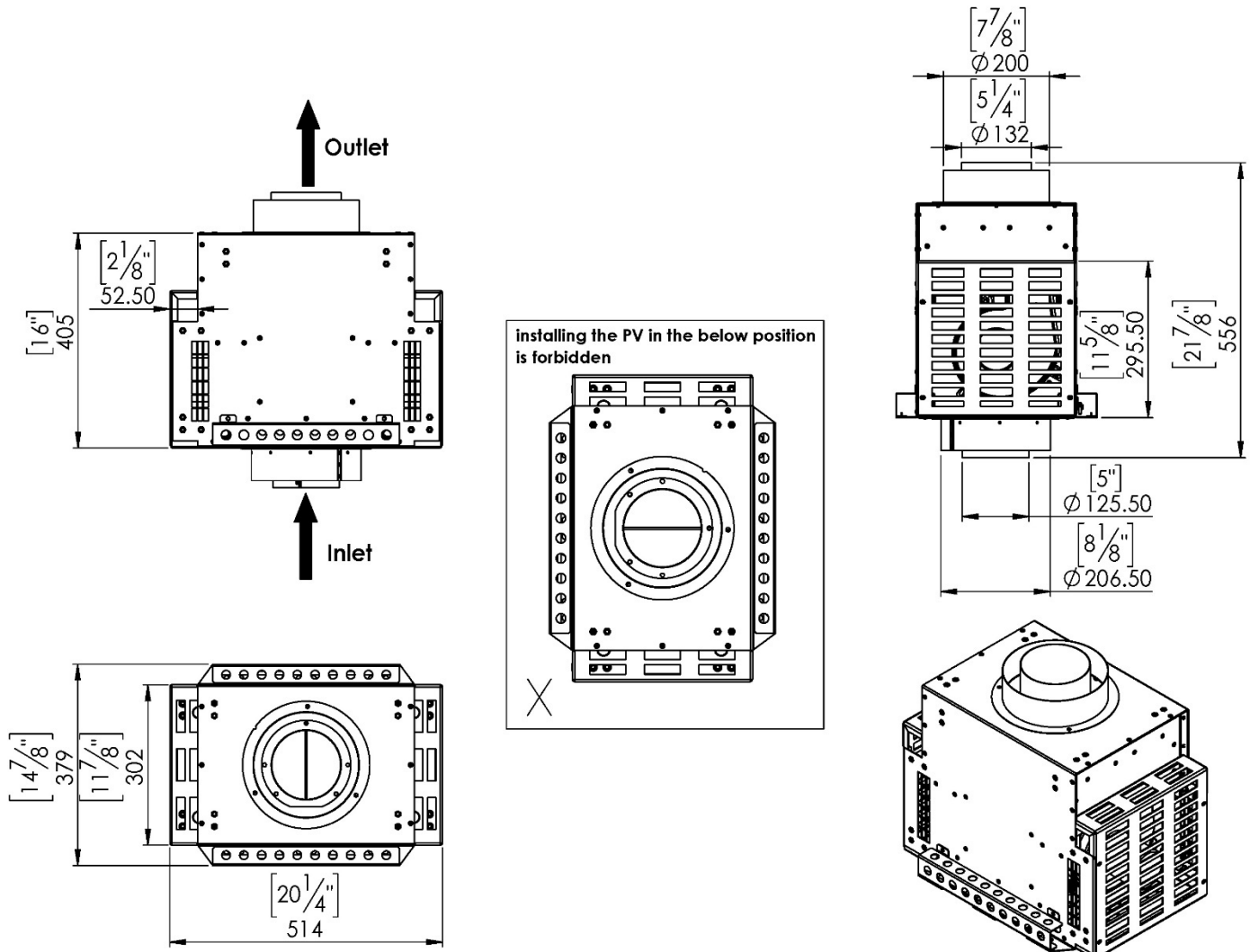

Dimensions for Inline Power Vent Max

Inline Power Vent Max Clearances

Maintain 4 inches of space around the power vent and 12 inches of space around both sides to the wall for ease of servicing. In the instance where two power vents are next to each other, each power vent requires 4 inches of clearance.

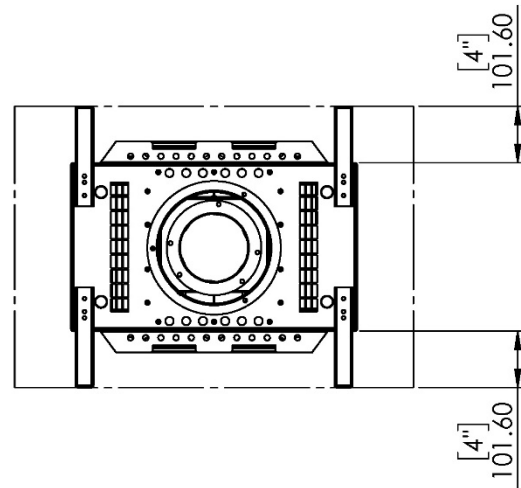
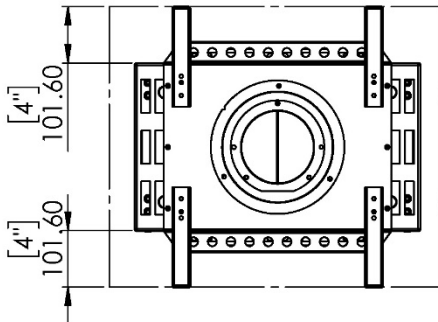
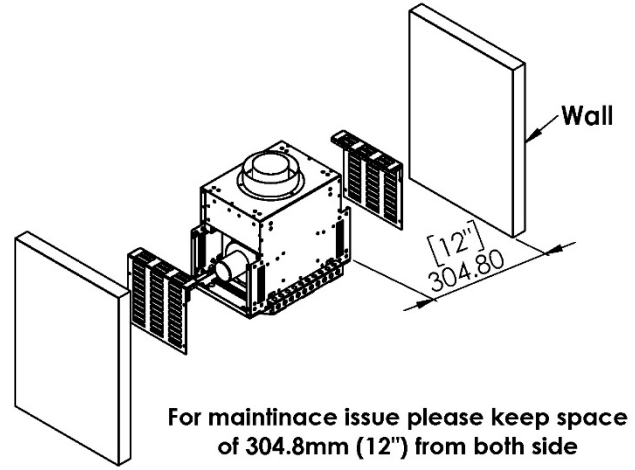

Inline Power Vent Max Clearances

IMPORTANT NOTE: Due to airflow considerations, it will not be possible to keep only 4 inches of clearance on every side. To keep the component operating temperature cool, power vent must be located in an area with a min. 35 cubic feet of air space AND have an air intake that allows min. 100 square inches of net free air space.

It is recommended to use a louvered access panel (used for servicing the power vent) that meets the min. 100 square inches of net free air space requirement.

Vent Termination Clearances

Horizontal Termination Clearance Diagram

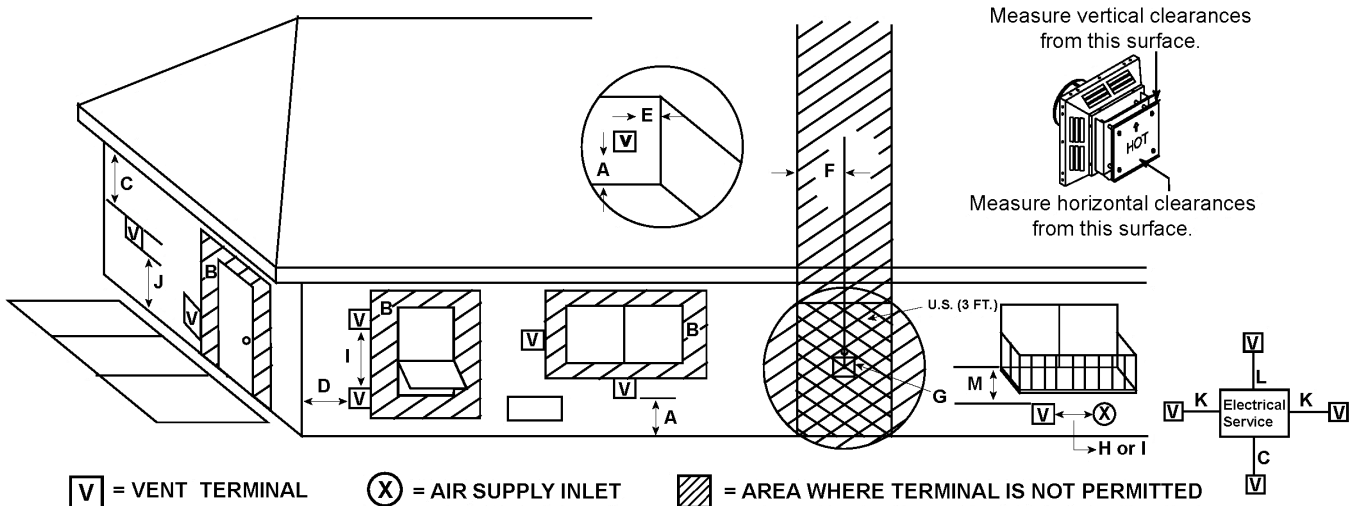

Location	Country	Minimum Clearance	Description
A	US & Canada	12 inches	Clearance above grade, veranda, porch, deck, or balcony. NOTE: On private property where termination is less than 7 feet above a sidewalk, driveway, deck, porch, veranda, or balcony, use of a listed cap shield is suggested.
B	US	≤ 50,000 BTU: 9 inches > 50,000 BTU: 12 inches	Clearance to an operable window or door. NOTE: Zero clearance to an inoperable window or door.
	Canada	12 inches	
C	US & Canada	24 inches	Vertical clearance to a ventilated soffit located above the vent termination.
		18 inches	Vertical clearance to an unventilated soffit located above the vent termination.
		42 inches	Vertical clearance to vinyl clad soffits and below electrical service.
D	US & Canada	9 inches	Clearance to an outside corner.
E	US & Canada	6 inches	Clearance to an inside corner.
F	US	N/A	Not to be installed above a gas meter/regulator assembly within 3 feet (90 cm) horizontally from the centerline of the regulator.
	Canada	3 feet	
G	US & Canada	3 feet	Clearance to gas service regulator vent outlet.
H	US	9 inches	Clearance to a non-mechanical air supply inlet to the building or the combustion air inlet to any other appliance. NOTE: Termination in a covered alcove space (spaces open only on one side and with an overhang) are permitted with the dimensions specified for vinyl or non-vinyl siding and soffits. 1. There must be 3 feet minimum between termination caps. 2. All mechanical air intakes within 10 feet of a termination cap must be a minimum of 3 feet below the termination cap. 3. All gravity air intakes within 3 feet of a termination cap must be a minimum of 1 foot below the termination cap.
	Canada	12 inches	
I	US	3 feet	Clearance to a mechanical (powered) air supply inlet. NOTE: Termination in a covered alcove space (spaces open only on one side and with an overhang) are permitted with the dimensions specified for vinyl or non-vinyl siding and soffits. 1. There must be 3 feet minimum between termination caps. 2. All mechanical air intakes within 10 feet of a termination cap must be a minimum of 3 feet below the termination cap. 3. All gravity air intakes within 3 feet of a termination cap must be a minimum of 1 foot below the termination cap.
	Canada	6 feet	
J*	US & Canada	7 feet	Clearance above paved sidewalk or a paved driveway located on public property. NOTE: On private property where termination is less than 7 feet above a sidewalk, driveway, deck, porch, veranda, or balcony, use of a listed cap shield is suggested. *a vent shall not terminate directly above a sidewalk or paved driveway which is located between two single family dwellings and serves both dwellings.
K	US & Canada	6 inches	Clearance from sides of electrical service. NOTE: Location of the vent termination must not interfere with access to the electrical service.
L	US & Canada	12 inches	Clearance above electrical service. NOTE: Location of the vent termination must not interfere with access to the electrical service.

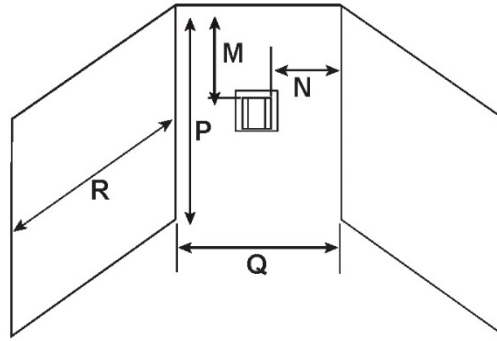

Covered Alcove: spaces open only on one side and with an overhang

Horizontal Termination Clearances Continued: Covered Alcove Application				
Location	Country	Minimum Clearance	Description	
COVERED ALCOVE APPLICATION	M	US & Canada	16 inches	Clearance under non-vinyl veranda, porch, deck, balcony, or overhang. NOTE: Termination in a covered alcove space is permitted with the dimensions specified. 1. There must be 3 feet minimum between termination caps. 2. All mechanical air intakes within 10 feet of a termination cap must be a minimum of 3 feet below the termination cap. 3. All gravity air intakes within 3 feet of a termination cap must be a minimum of 1 foot below the termination cap.
	N	US & Canada	6 inches	Non-vinyl sidewalls.
			12 inches	Vinyl sidewalls.
	P	US & Canada	8 feet	Alcove height.
	Q	US & Canada	See table below.	Alcove width (dependent on number of caps in the space).
R	US & Canada	See table below.	Alcove depth (dependent on number of caps in the space).	

# Vent Caps	Q _{MINIMUM}	R _{MAXIMUM}
1 vent cap	3 feet	2 x Q _{ACTUAL}
2 vent caps	6 feet	1 x Q _{ACTUAL}
3 vent caps	9 feet	² / ₃ x Q _{ACTUAL}
4 vent caps	12 feet	¹ / ₂ x Q _{ACTUAL}
	Q_{MIN} = # vent caps x 3	R_{MAX} = (²/_{# vent caps}) x Q_{ACTUAL}

! HORIZONTAL TERMINATION CAP CLEARANCES - NOTES:

- If exterior walls are finished with vinyl siding, it is required that a vinyl protector kit be installed.
- Vent system termination is not permitted in screened porches.
- Vent system termination is permitted in porch areas with two or more sides open. You must follow all side walls, overhang and ground clearances as stated.
- Termination caps may be hot. Consider their proximity to doors or other traffic areas.

! TERMINATION CAP NOTE: A Sconce Termination Cap can negatively impact flame appearance and is not recommended for use with the fireplace.

Vertical Termination Clearance Diagram

Minimum Height From Roof To Lowest Discharge Opening

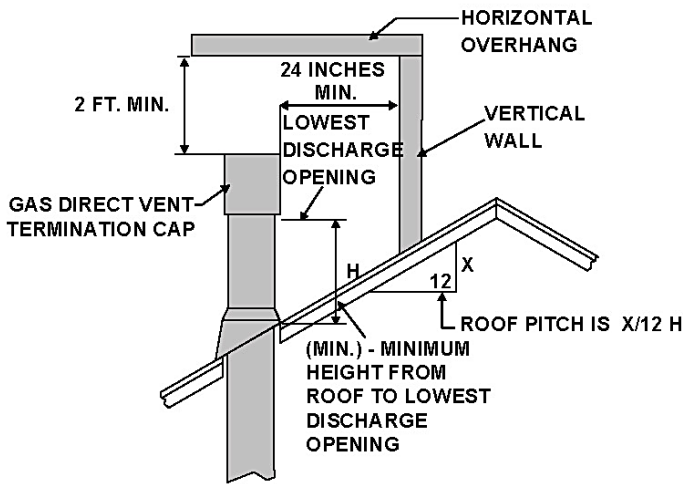

Roof Pitch	H (Min.) Ft.
Flat to 6/12.....	1.0*
Over 6/12 to 7/12.....	1.25*
Over 7/12 to 8/12.....	1.5*
Over 8/12 to 9/12.....	2.0*
Over 9/12 to 10/12.....	2.5*
Over 10/12 to 11/12.....	3.25
Over 11/12 to 12/12.....	4.0
Over 12/12 to 14/12.....	5.0
Over 14/12 to 16/12.....	6.0
Over 16/12 to 18/12.....	7.0
Over 18/12 to 20/12.....	7.5
Over 20/12 to 21/12.....	8.0

*H min. may vary depending on regional snowfall. Refer to local codes.

Staggered Termination Caps

A	B
6 in. (minimum) up to 24 in.	18 in. minimum
24 in. and over	0 in. minimum

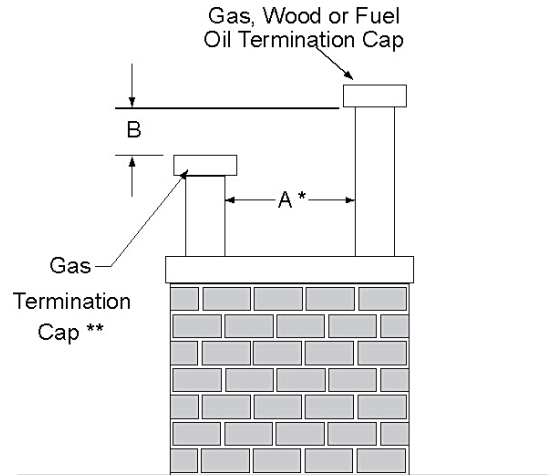

* If using decorative cap cover(s), this distance may need to be increased. Refer to the installation instructions supplied with the decorative cap cover.

** In a staggered installation with both gas and wood or fuel oil terminations, the wood or fuel oil termination cap must be higher than the gas termination cap.

Notes:

1. Maintain a minimum of 2 feet clearance between edge of vertical termination and perpendicular wall.
2. If terminating near window, keep minimum of 2 feet clearance between window and vent termination.
3. All mechanical air intakes (such as an Enervex power vent) within 10 feet of a termination cap must be a minimum of 3 feet below the termination cap.
4. All gravity air intakes within 3 feet of a termination cap must be a minimum of 1 foot below the termination cap.

NOTE: This chart does not apply to a chimney shroud application. See the “Chimney Shroud” section for more information.

TERMINATION CAP NOTE: A Low-Profile Termination Cap can negatively impact flame appearance and is not recommended for use with the fireplace.

Horizontal End-Line Power Vent Max

The Power Vent Max is required for use with the Wilderness 77 Series fireplaces. Under the few circumstances where the Ortal Power Vent Max might not be the perfect fit, the Energex RS Series Power Vent System can be substituted. For information on the Energex RS Series Power Vent System, please refer to the Ortal Energex RS Power Vent manual.

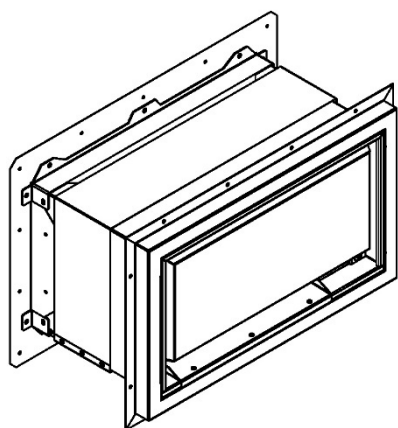

Horizontal End-Line Power Vent Max Fan Box

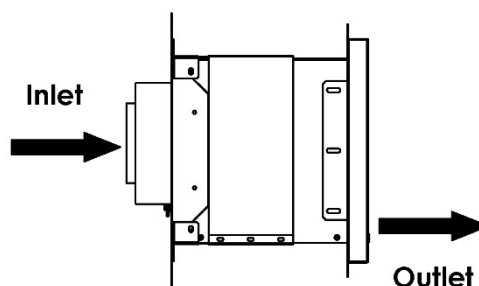

Power Vent Air Flow

Pre-Installation Considerations

Before you begin installation of the power vent, ensure you have planned for the following:

- Electrical requirements (see “Electrical” section for details)
- Local codes and regulations
- Power vent fan box and venting pipe clearance requirements (see “Horizontal End-Line Power Vent Max Clearances” and “Vent Clearances” sections for details)
- Termination location (location must be accessible for servicing)
- Total venting run length and number of elbows (see all sections under “Venting Requirements” for details)
- Power Vent Max must be at minimum 8 feet from the fireplace.

IMPORTANT: Read Before You Begin

Vent Installation: For vent component installation instructions, refer to manufactures instructions for gas appliances.

Review all clearance and venting requirements, pre-installation considerations for both the venting and the power vent, and local code before beginning installation.

Ensure all materials, system components, and tools necessary are present, and in good condition at the time of installation.

Venting may be installed independently of the fireplace and power vent fan if needed, as site conditions permit.

Installation Instructions

Step 1: Install the Control Box

1. Place control box near the minimum 12"x12" control box access panel.

 **WARNING:** To avoid operational malfunctions, control box must be oriented with "This Side Up" wording facing up and the feet facing down.

Step 2: Install the Power Vent

1. Refer to "NOTE: Diagrams are intended for illustrative purposes only. All local codes and building requirements must be consulted.
2. Application Options from Step 2" section below and install the power vent according to desired application.
3. Install venting components leading from the fireplace up to the location of the power vent.
4. Attach venting pipe to exhaust inlet on the power vent.



Step 3: Connect the Power Vent to the Control Box

1. Insert the pig-tailed end of the 62-foot power cable (supplied) to the power vent **control box** through the cable clamp.
2. Open the power vent service door and connect the cable's pig-tailed end to the pig tail located in the **power vent**. Make sure all connections are tight and secure.
3. Plug the control box into the outlet inside the access panel area as per the Ortol fireplace installation instructions. See "Electrical" section for details.

NOTES:

- Electrical connections should be completed by a certified electrician, and in accordance with local building codes.
- A protective layer of grease is used in the manufacturing process of the venting. The heat burns away this grease and can cause some smoking and smell during the initial running, which should dissipate within the first few hours of use.

 **WARNING:** This smoke could set off a fire alarm. Anyone with an integrated smoke alarm system needs to be aware.

 **NOTE:** Diagrams are intended for illustrative purposes only. All local codes and building requirements must be consulted.

Application Options from Step 2

Option 1: Flush Installation: Wall Thickness Less Than 7 1/2"

NOTES:

- Must have space for a 10" power vent depth.
- If a 90-degree elbow is directly connected to the power vent, a minimum of 24" depth is necessary (includes power vent, adapter, 90-degree elbow, and 1" clearance).

Instructions

1. Prepare an opening size **12 1/2" high x 22 1/2" wide**. Surrounding material may be combustible or non-combustible.

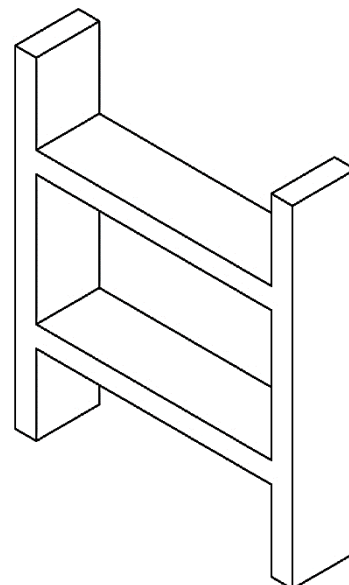
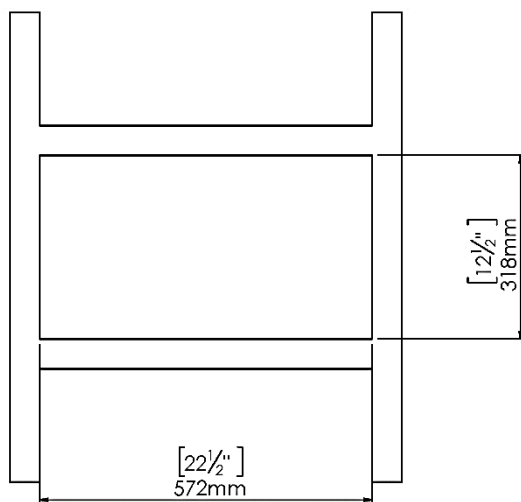

2. Position the external retaining cover as shown in the diagram below. Seal flange and power vent fan box using weather-proof caulking.

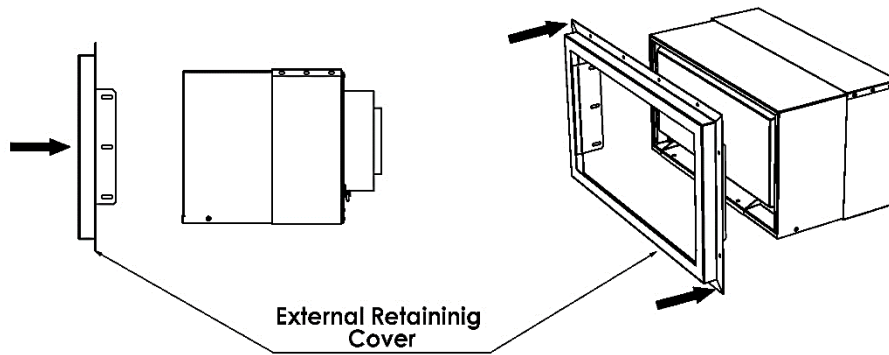

3. Insert the power vent fan box into position.

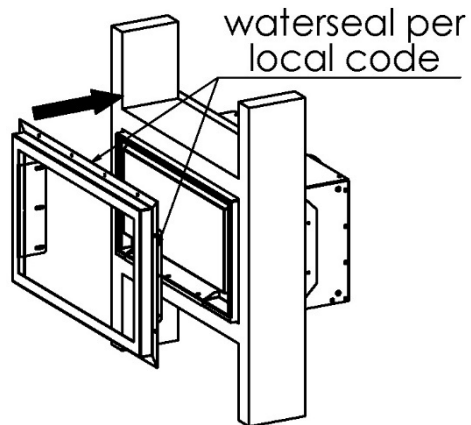

4. Position and secure the 'inner wall plate' (draft stop) into place.

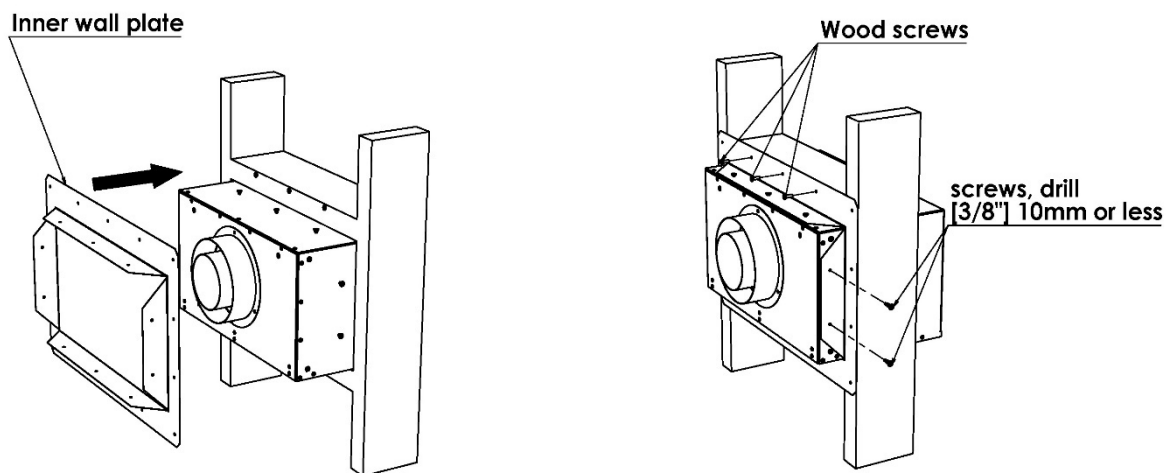

5. Prepare the wall finish. The finish should be no deeper than $1 \frac{15}{16}$ ".

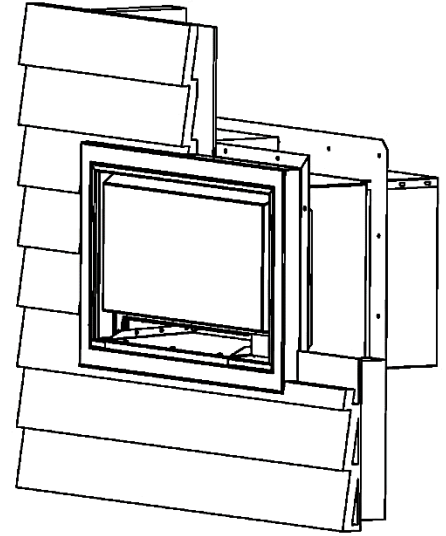
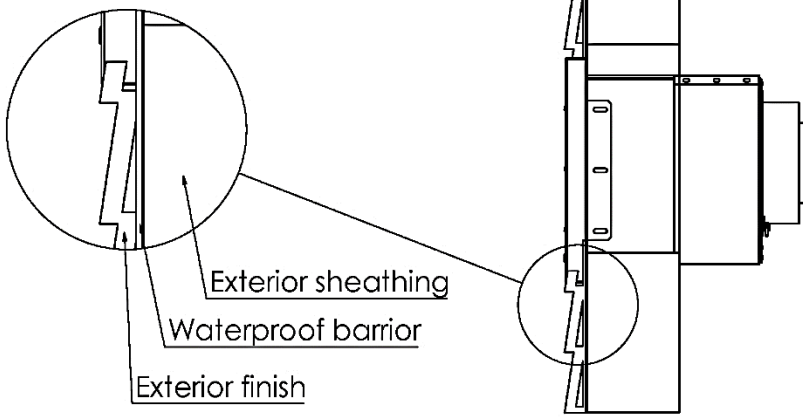
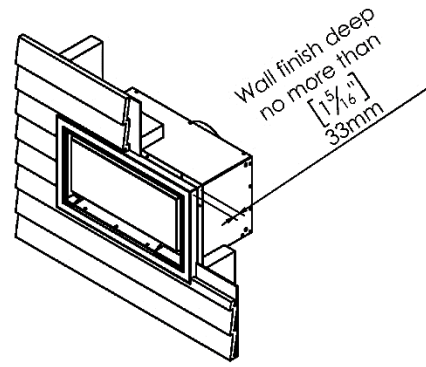
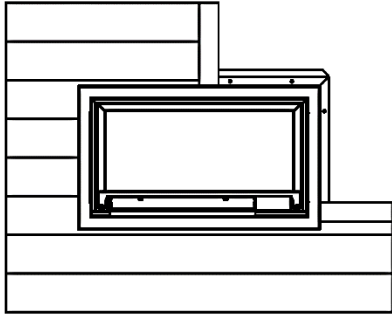

Option 2: Flush Installation: Wall Thickness 7 1/2" - 16"

NOTES:

- Must have space for a 10" power vent depth.
- If a 90-degree elbow is directly connected to the power vent, a minimum of 24" depth is necessary (includes power vent, adapter, 90-degree elbow, and 1" clearance).
- Framing can be non-combustible or combustible. Images below are shown alternating between both options.

Instructions

1. Connect the two parts together (Image 1 below), insert the assembly into the wall and secure to framing (Images 2 and 3 below).

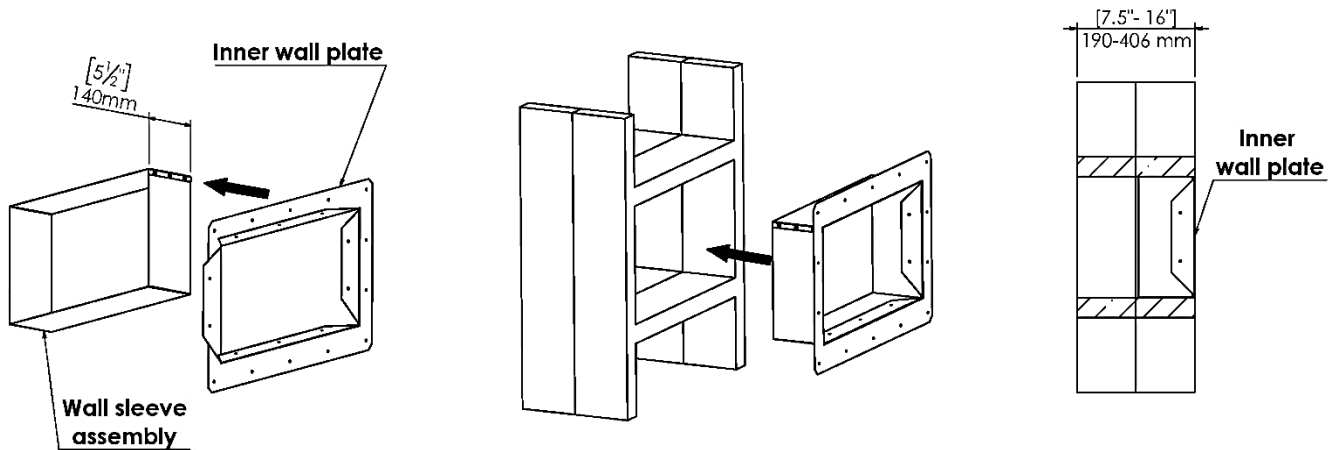

2. Position the external retaining cover as shown in the diagram below.

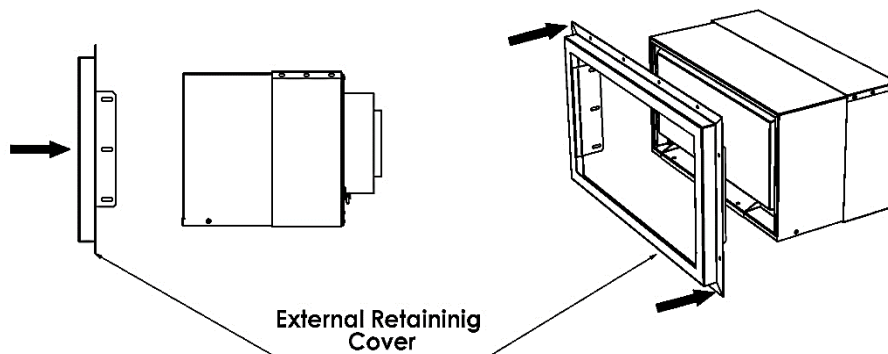

3. Insert the power vent fan box into position.

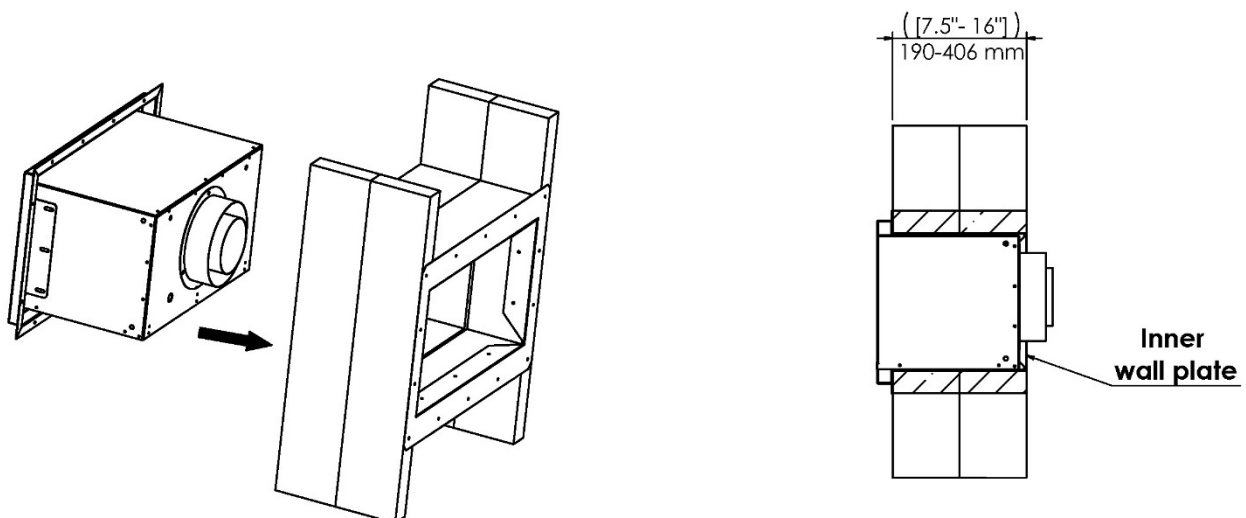

Option 3: Extended Power Vent Application

Instructions

1. Install the power vent referring to step 1 instructions from "Wall Thickness 7 1/2" - 16".
2. Refer to the diagram below for remaining instructions. Seal all gaps with silicon after installation (be sure to consult local codes regarding sealing requirements).

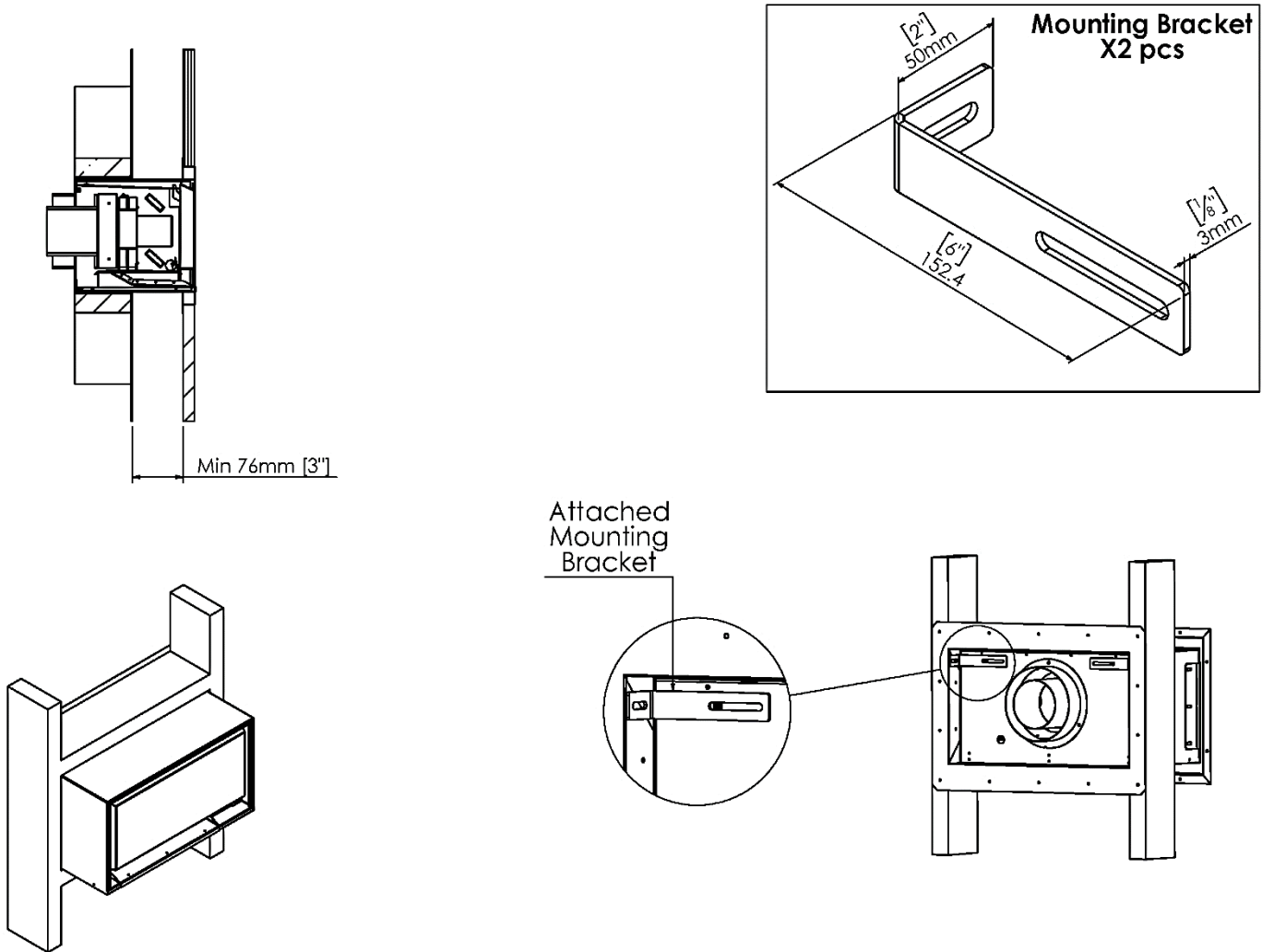

Option 4: Stucco Walls

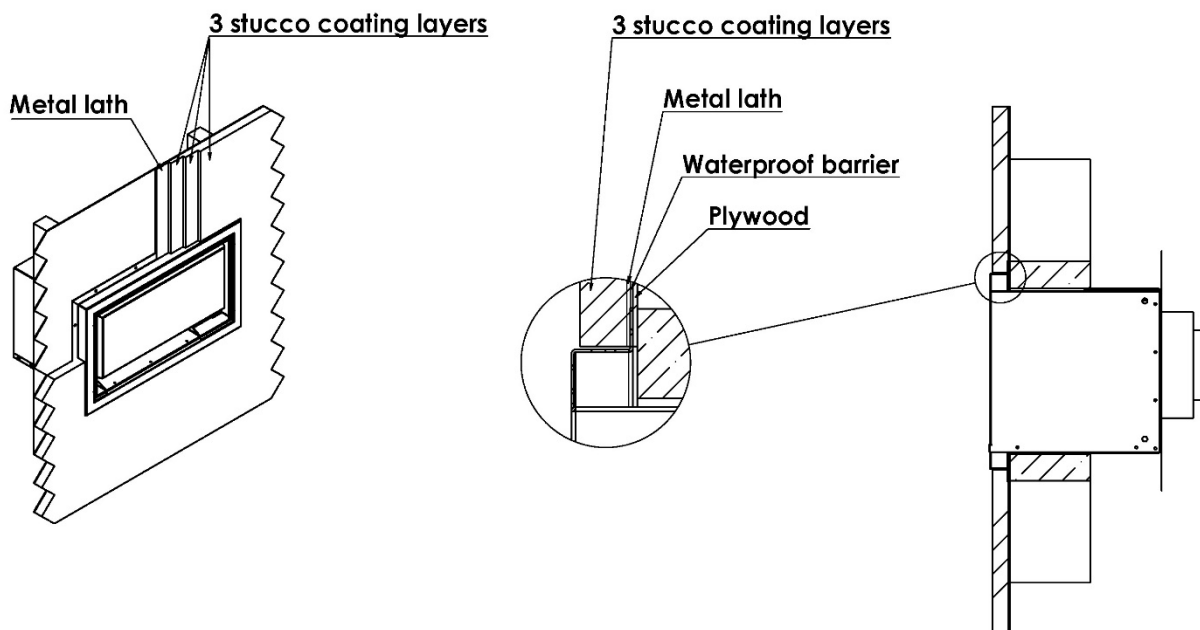

Horizontal End-Line Power Vent Max Dimensions

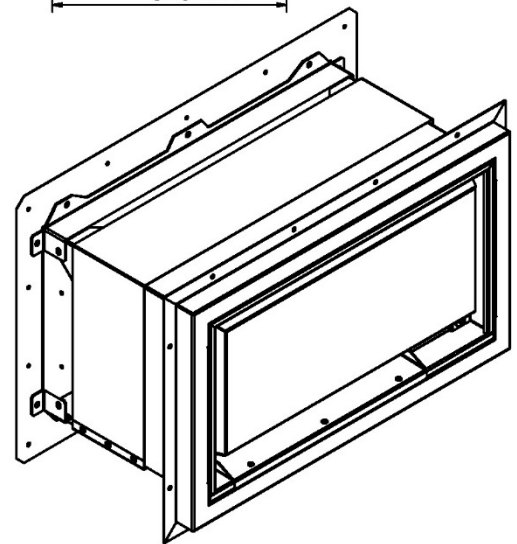
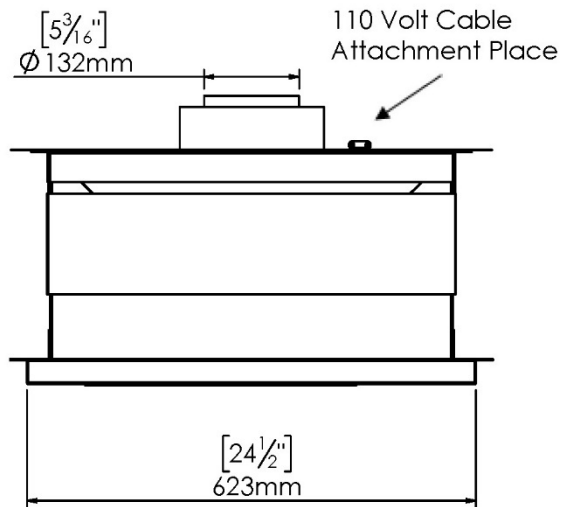
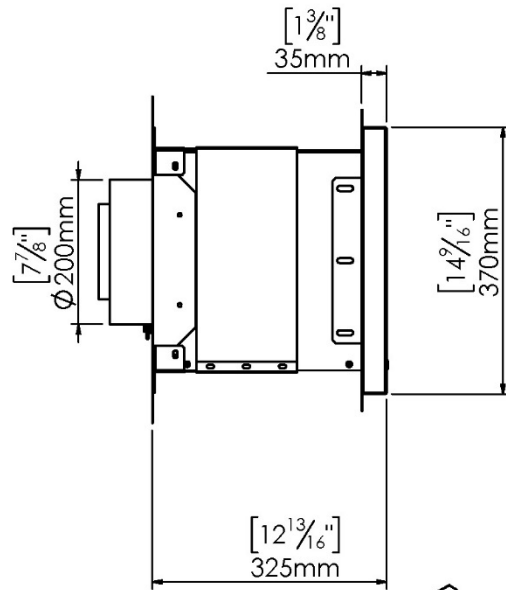
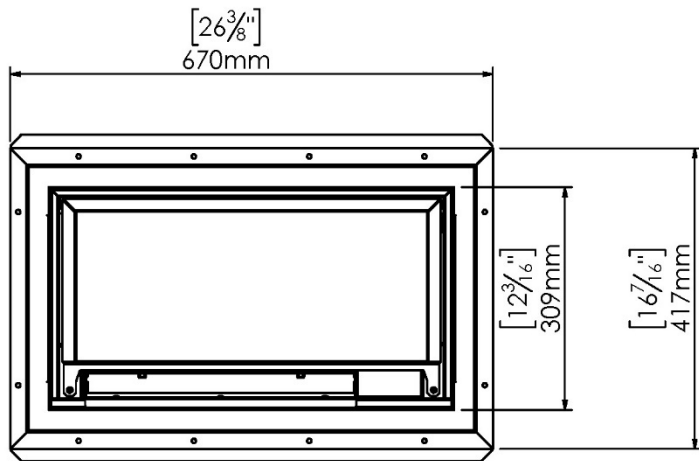

Dimensions for Horizontal End- Line Power Vent Max

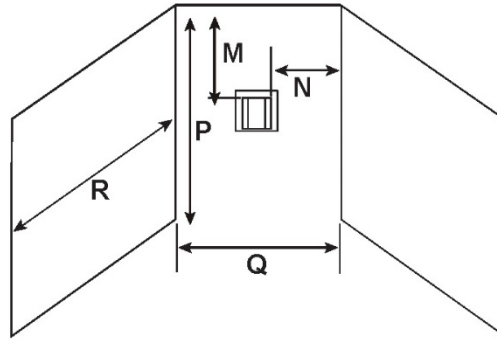

Covered Alcove: spaces open only on one side and with an overhang

Horizontal Termination Clearances Continued: Covered Alcove Application				
Location	Country	Minimum Clearance	Description	
COVERED ALCOVE APPLICATION	M	US & Canada	16 inches	Clearance under non-vinyl veranda, porch, deck, balcony, or overhang. NOTE: Termination in a covered alcove space is permitted with the dimensions specified. 1. There must be 3 feet minimum between termination caps. 2. All mechanical air intakes within 10 feet of a termination cap must be a minimum of 3 feet below the termination cap. 3. All gravity air intakes within 3 feet of a termination cap must be a minimum of 1 foot below the termination cap.
	N	US & Canada	6 inches	Non-vinyl sidewalls.
			12 inches	Vinyl sidewalls.
	P	US & Canada	8 feet	Alcove height.
	Q	US & Canada	See table below.	Alcove width (dependent on number of caps in the space).
R	US & Canada	See table below.	Alcove depth (dependent on number of caps in the space).	

# Vent Caps	Q _{MINIMUM}	R _{MAXIMUM}
1 vent cap	3 feet	2 x Q _{ACTUAL}
2 vent caps	6 feet	1 x Q _{ACTUAL}
3 vent caps	9 feet	² / ₃ x Q _{ACTUAL}
4 vent caps	12 feet	¹ / ₂ x Q _{ACTUAL}
	Q_{MIN} = # vent caps x 3	R_{MAX} = (²/_{# vent caps}) x Q_{ACTUAL}

! HORIZONTAL TERMINATION CAP CLEARANCES - NOTES:

- If exterior walls are finished with vinyl siding, it is required that a vinyl protector kit be installed.
- Vent system termination is not permitted in screened porches.
- Vent system termination is permitted in porch areas with two or more sides open. You must follow all side walls, overhang and ground clearances as stated.
- Termination caps may be hot. Consider their proximity to doors or other traffic areas.

! TERMINATION CAP NOTE: A Sconce Termination Cap can negatively impact flame appearance and is not recommended for use with the fireplace.

Venting Requirements

The fireplace operates using a direct vent system and requires co-axial direct vent pipe. The fireplace must be properly connected to an approved vent system. Venting is not provided with the fireplace and must be sourced from one of the approved vent manufacturers mentioned in the table below. Proper installation, use, and maintenance of venting is determined by and can be acquired from the vent manufacturer.

IMPORTANT: Wilderness 77 models require a power vent for operation. Ortal Power Vent Max is the recommended choice. Under the few circumstances where the Ortal Power Vent Max might not be the perfect fit, the Energex RS Power Vent can be substituted. A standard Ortal Power Vent (as mentioned in the Ortal Power Vent Manual) cannot provide adequate air flow and must not be used with any Wilderness 77 series fireplaces.

Vent Requirements			
Fireplace Model	Direct Vent Type	Vent Size	Approved Vent Manufacturers
Wilderness 77 Front Wilderness 77 RS Wilderness 77 LS Wilderness 77 TS	Ortal Power Vent Max (recommended)	5x8 co-axial direct vent pipe (5" interior, 8" exterior)	Olympia: Ventis DuraVent: Direct Vent Pro ICC: EXCELDirect BDM: Pro-Form Direct Vent System Selkirk: Direct-Temp System
	Energex RS Power Vent (optional)		

 **ENERVEX POWER VENT NOTES:** See Ortal's Energex RS Power Vent Manual for more details on power venting with an Energex power vent.

 **WARNING:** Do not combine vent components from different vent manufacturers. Please follow the manufacturer's instructions for vent system installation.

Vent Configurations

Wilderness 77 Series + Power Vent (Wilderness 135-3 Burner)		
Ortal Power Vent Max (recommended) or Energex RS009 Power Vent (optional)	Min. Total Run: 8 feet	Max. Total Run: 52 feet
	Max Elbows: 4 x 90°	Max. Vertical Drop: 6 ft
Energex RS014 Power Vent (optional)	Min. Total Run: 8 feet	Max. Total Run: 52 feet
	Max Elbows: 6 x 90°	Max. Vertical Drop: 15 ft

Vent Restrictor Sizing Guidelines

The restrictor sizing tables in this section determine the recommended restrictor for your vent configuration. These tables show Ortal's recommendations only. The Environment, gas type and other factors may affect the best restrictor choice.

How to use the "Recommended Restrictor" tables:

- Find the total vertical rise in your vent configuration along the y-axis.
- Find the horizontal run in your vent configuration along the x-axis.
- Follow the desired rise and run values within the table until they meet. This value is the recommended restrictor size (in inches) for your vent configuration.

Legend:

X: Vent configuration is not allowed. Power vent required.

0: No restrictor required.

Numbers other than 0: Represents the recommended restrictor (by width).

Restrictor Sizes:

- 20mm (0.79")
- 30mm (1.18")
- 40mm (1.57")
- 50mm (1.97")
- 70mm (2.75")
- 85mm (3.35")

Wilderness 77 Series + Power Vent (any)		
Min. Total Run: 8 feet		
Total Vertical Vent Rise	31'-52'	0
	15'-30'	1.18"
	8'-14'	1.97"
	0'-7'	X
		8-52'
		Horizontal Vent Run

Vent Clearances

The following clearances apply to the vent system regardless of vent manufacturer.

Vent Clearances	
Sides: 1"	Applies to entire circumference when venting is oriented vertically. Clearance is to any material.
*Top: 3"	Applies to venting oriented horizontally or at an angle. Clearance is to any material.
Bottom: 1"	

***Exception:** Wall thimble top clearance to any material is 1".

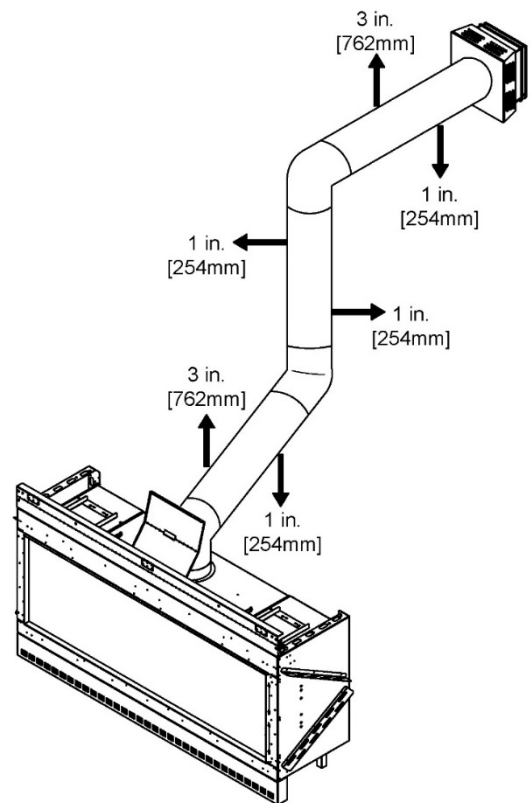

NOTE: The vent clearance diagram above is for illustration purposes only. The Ortal Power Vent Max, not shown in the diagram, is required for optimal operation of the fireplace.

Chimney Shroud

Top Open

Keep a minimum **6-inch** clearance around the diameter of the cap's side edge and extending above and below the cap.

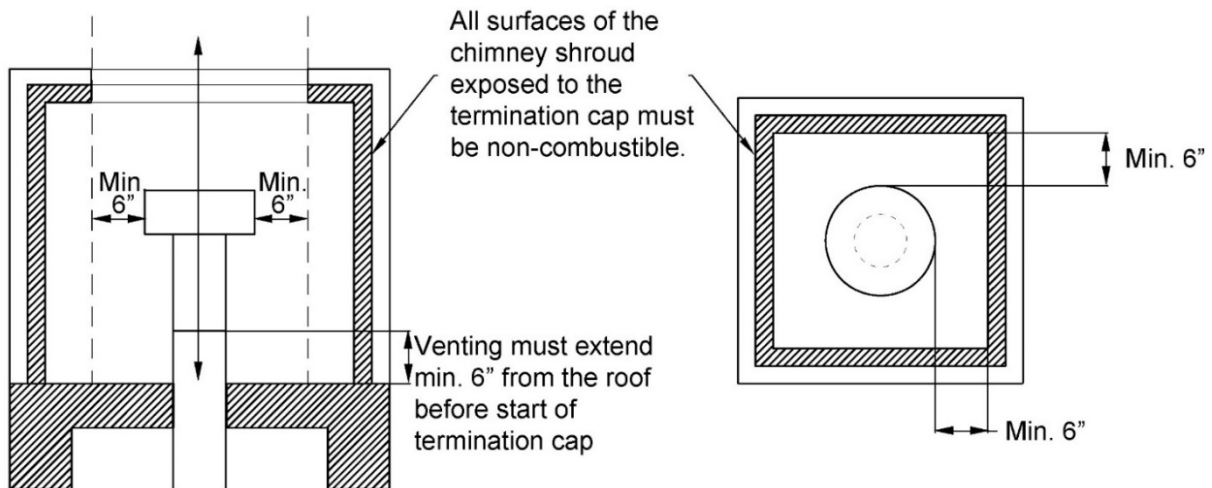

Sides Open

Keep a minimum **6-inch** clearance around the diameter of the cap's side edge, and a minimum **10-inch** clearance above the top of the cap. For openings in the shroud, make sure to allow for enough air flow space to release the exhaust gases and allow the vent to operate properly.

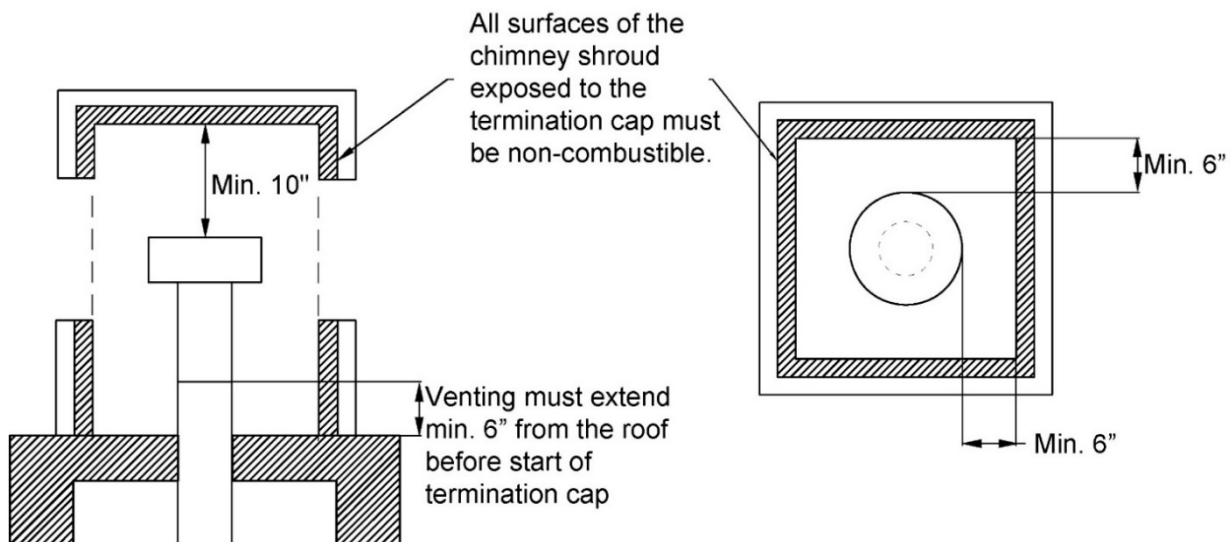

Vent Installation

Venting must be installed to meet the requirements as detailed in the following sections in conjunction with the vent system manufacturer's installation instructions. Venting must be supported by the structural surrounding and not by the fireplace. Each offset (elbow) must be strapped to reduce movement or possible disconnection.

The first section of venting must be secured to the fireplace starter collar with a minimum of 3 sheet metal screws no longer than $\frac{1}{2}$ ". DO NOT use silicone to seal the sections. If sealing is required by the vent manufacturer or local code, use Mil-Pac sealant or equivalent.

WARNING: Do not combine vent components from different vent manufacturers. Please follow the manufacturer's instructions for vent system installation.

Vent Maintenance

Regular inspection of the vent system by a qualified service technician is recommended every six months. The following maintenance routing is recommended:

- Inspect for excessive condensation, e.g., water droplets forming in the inner lining, and subsequently dripping from the joints. This can cause corrosion in the system.
- Check for corrosion in areas exposed to the elements. Components with rust spots or holes must be immediately replaced.
- Ensure that there is no foreign material in the vents. Survey by removing the cap and shining a light down the vent.
- If possible, check all vent joints to make sure nothing has been disturbed or loosened.

Gas

The fireplaces are approved for use with natural gas (NG) or propane (LP) only. No other fuel types are permitted.

Gas Pressures

Fireplace Series	Firelog Burner	Gas Type	Inlet Pressure		Manifold Pressure	Heat Input (BTU/hr)		Orifice Size*
			Min	Max		Min	Max	
Wilderness 77 Front Wilderness 77 RS Wilderness 77 LS Wilderness 77 TS	Driftwood 135-3 (3 long logs)	Natural Gas	7.0	11.0	3.5	41,000	61,000	500-160-380-800
		Propane	11.0	13.0	5.0	50,000	57,000	260-60-180-380

*Wilderness Orifice Size, Top Row (left to right): Left log, center log, right log. Bottom Row: Bottom of burner.

! NOTE: It can take up to 20 minutes for the flames to turn yellow.

Routing the Gas Line

Correctly size and route the gas supply line from the supply regulator to the area where the access panel is located (or to the burner area if no access panel is available), as per the requirements outlined in the latest edition of the National Fuel Gas Code, NFPA 54 (USA) or CAN/CSA-B1491 (Canada).

The gas and electrical components are attached to the pilot on a flexible gas line and can be kept directly under the fireplace or, depending on the model, moved to the left, right, or back of the fireplace within 36 inches of the pilot (located at the center front of the burner). See images below for details.

Gas line should be routed to the access area (see "Access Area Requirements" section for details). If no access panel is planned, gas line should be routed to the most accessible area within the 36" radius.

A gas shut-off valve and a 12" gas flex connector are provided with every fireplace. The location of the gas shut-off valve is dependent on local codes and requirements. Check with your authority having jurisdiction for more information.

! WARNING: The main gas valve must be installed to allow complete disconnection of the fireplace from the gas supply piping system for servicing purposes.

Screen Models

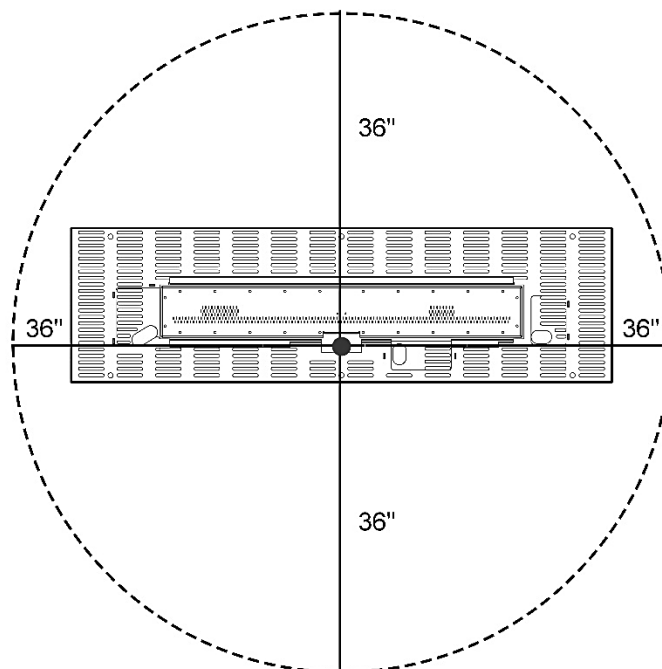

77 Series Fireplaces with Screen: Left, Right, Back, Front

Double Glass Models

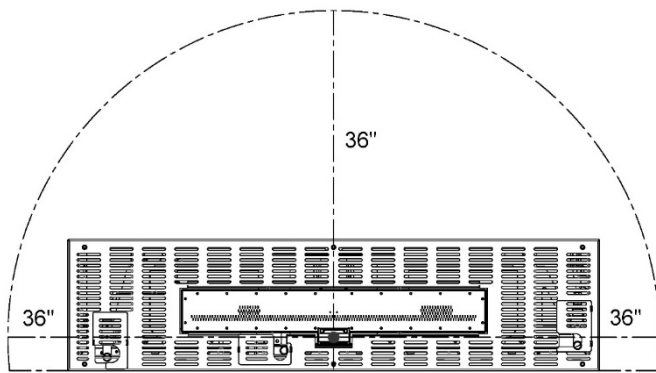

Front with Double Glass: Left, Right, Back

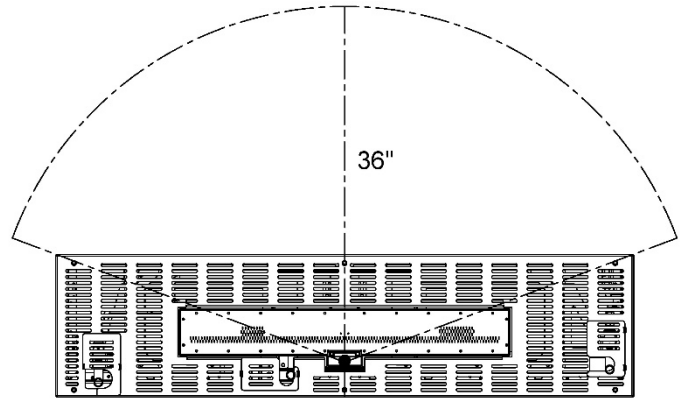

Three Sided with Double Glass: Back

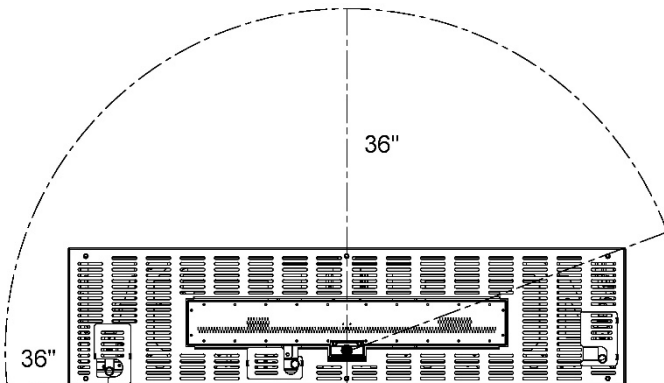

Right Side (RS) with Double Glass: Left, Back

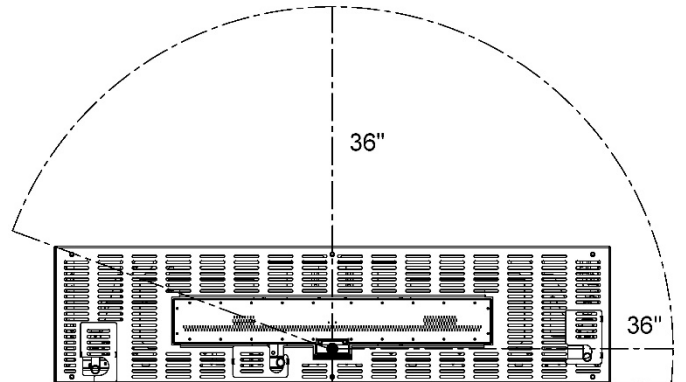

Left Side (LS) with Double Glass: Right, Back

Gas Conversion

For gas conversion (NG to LP or LP to NG) in the field, Firelogs for the desired gas type must have been ordered and on site before gas conversion can occur. Firelog installation and gas conversion must be performed only by technicians who have specific authorization by Ortal to change these components. The Driftwood Firelog Kit must be supplied by Ortal. Using parts from other manufacturers or having an unauthorized party performing the conversion will void your fireplace's warranty. Conversion instructions are supplied with the kit.

Driftwood 135-3 Firelog Set for Wilderness 77 Series Fireplaces, NG to LP: **SKU: GCNLLDW3LB1350-US**

Driftwood 135-3 Firelog Set for Wilderness 77 Series Fireplaces, LP to NG: **SKU: GCLNLDW3LB1350-US**

- NOTES:**
- Log sets for NG and LP have different SKUs. Please consult the price list to ensure you have the correct SKU.
 - LP logs do not contain nickel strands inside the logs. NG logs do contain nickel strands.

High Altitude Requirements

For elevations above 2,000 feet, the fireplace shall be re-rated 4% for each 1,000 feet above sea level.

In Canada: Input ratings are certified without a reduction of input rate for elevations up to 4500 feet above sea level. Please consult provincial and/ or local authorities having jurisdiction for installations at elevations above 4500 feet.

→ Gas and Electrical Components

Assemblies and components are listed and described in the tables following the figure.

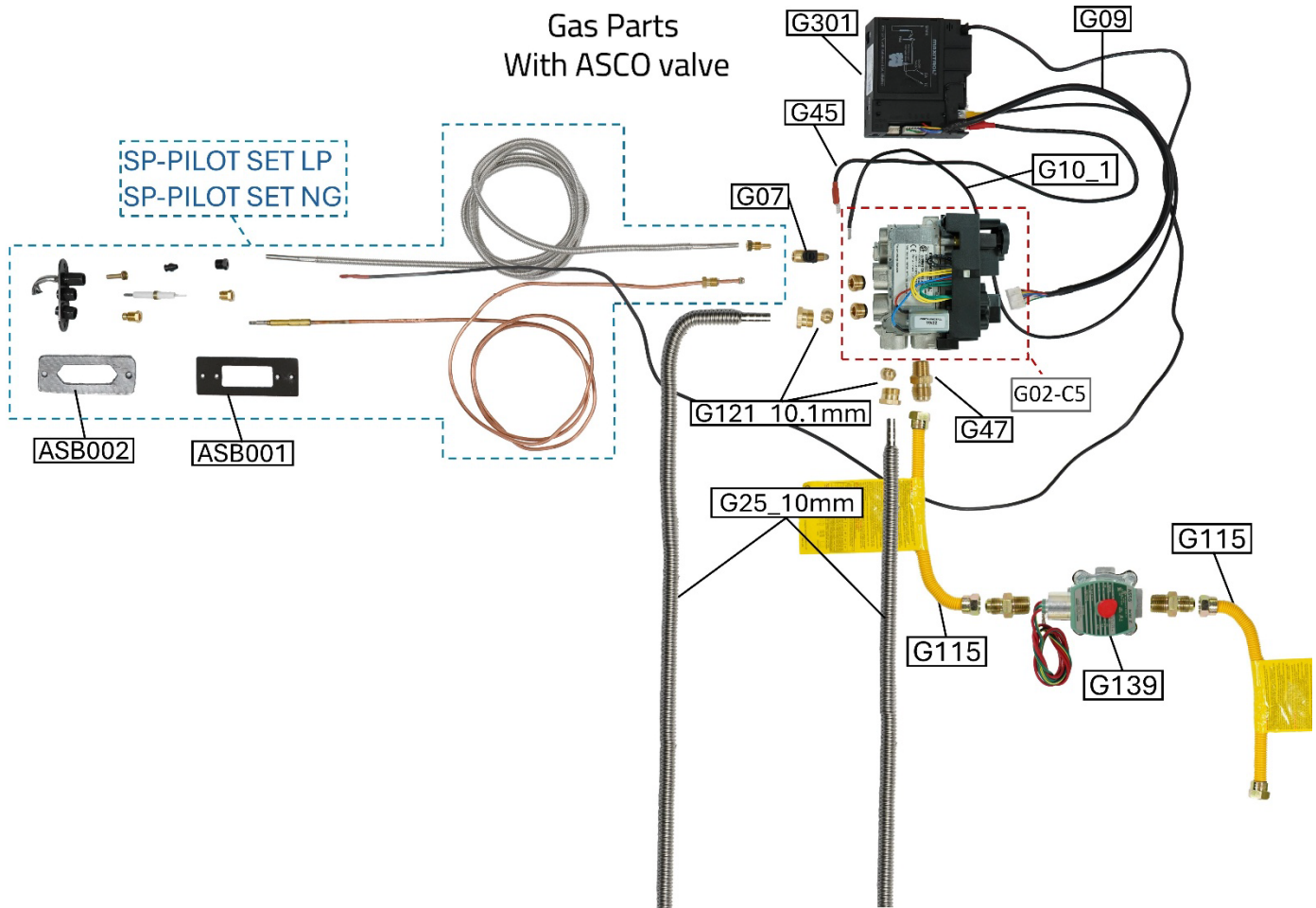

Part Number	Description
ASB001	Pilot Bracket
ASB002	Pilot Gasket
SP=PILOT SET NG	NG Pilot Assembly
SP-PILOT SET LP	LP Pilot Assembly
G301	Symax Receiver
G45	Red Cable
G10_1	Yellow Cable
G09	8 Pin Wire Harness

Part Number	Description
G121_10.1mm	Main Burner Fitting
G25_10mm	Burner Gas Tube
G02-C5	Mertik Gas Valve
G07	Thermocouple Block
G47	Main Line Gas Fitting for Valve
G115	Yellow Gas Tube 1/2"
G139	ASCO Gas Solenoid

The manufacturer of Ortal's gas and electrical components is Mertik Maxitrol. For information on these components, please visit the manufacturer's website: www.mertikmaxitrol.com

Electrical

WARNING: Disconnect the power supply before servicing any electrical components.

Electrical Requirements

A duplex receptacle with three outlets (not included) must be installed in the location where the gas and electrical components will be placed, which must be to the side or back of the fireplace within **36 inches** of the pilot (see diagram in "Routing the Gas Line" section). Electrical work should be performed by a qualified licensed electrician, per local code.

Electrical Outlet Requirements		
Outlet Type	Power Requirements	Location
Duplex Receptacle (With 3 outlets)	120V, 15 amp, 60Hz	Located near the access panel location (Or according to local code)

Power is supplied to the power vent fan from the power vent control box via the supplied 62-foot Power Cable. The power vent power cable and the fireplace AC Adapter will be plugged into this receptacle.

NOTE: The Power Vent System requires a continuous power supply and will not operate on battery power or during power failure.

NOTE: Any device that functions using the same radio frequency as the handset will be affected when remote-controlled handset is in use.

Power Outage



Wilderness 77 series fireplaces are required to be plugged into an outlet for the power vent to function. The fireplace cannot operate safely on battery power alone, and therefore cannot be operated in the event of a power outage.

Pairing the Remote and Receiver

To set up the remote-control device to operate the fireplace, follow the following guidelines to pair the remote and receiver unit on the same radio frequency.

1. Press and hold the receiver's reset button until you hear two beeps. The first beep is short, and the second beep is long. After the second beep, release the reset button.



2. Within the subsequent 20 seconds, press the following button depending on the mode of operation:
 - **10-Button Handset:** Press the  button. "CONN" and a running number from 1 to 8 will appear on the handset display confirming that the synchronization and data exchange are in process.
 - **Puck Handset:** Press and hold the  button approximately 4 seconds.
 - **Wall Switch:** Use the 10-button handset to synch with the receiver. Once the remote and receiver are paired, the wall switch will function normally.
 - **MyFire App:** Use the 10-button handset to synch with the receiver. Once the remote and receiver are paired, the App will function normally.
3. You will hear two short beeps confirming the connection.

NOTES:

- If you hear one long beep, this indicates the connection has failed or the wiring is incorrect.
- The connection between remote and receiver only needs to be made once and is not required after changing the batteries in the remote.

→Wiring Diagrams

The following diagrams show the electrical wiring required for different feature combinations.

Wiring Diagram: Screen Fireplace with Interior Lighting and Power Vent Max

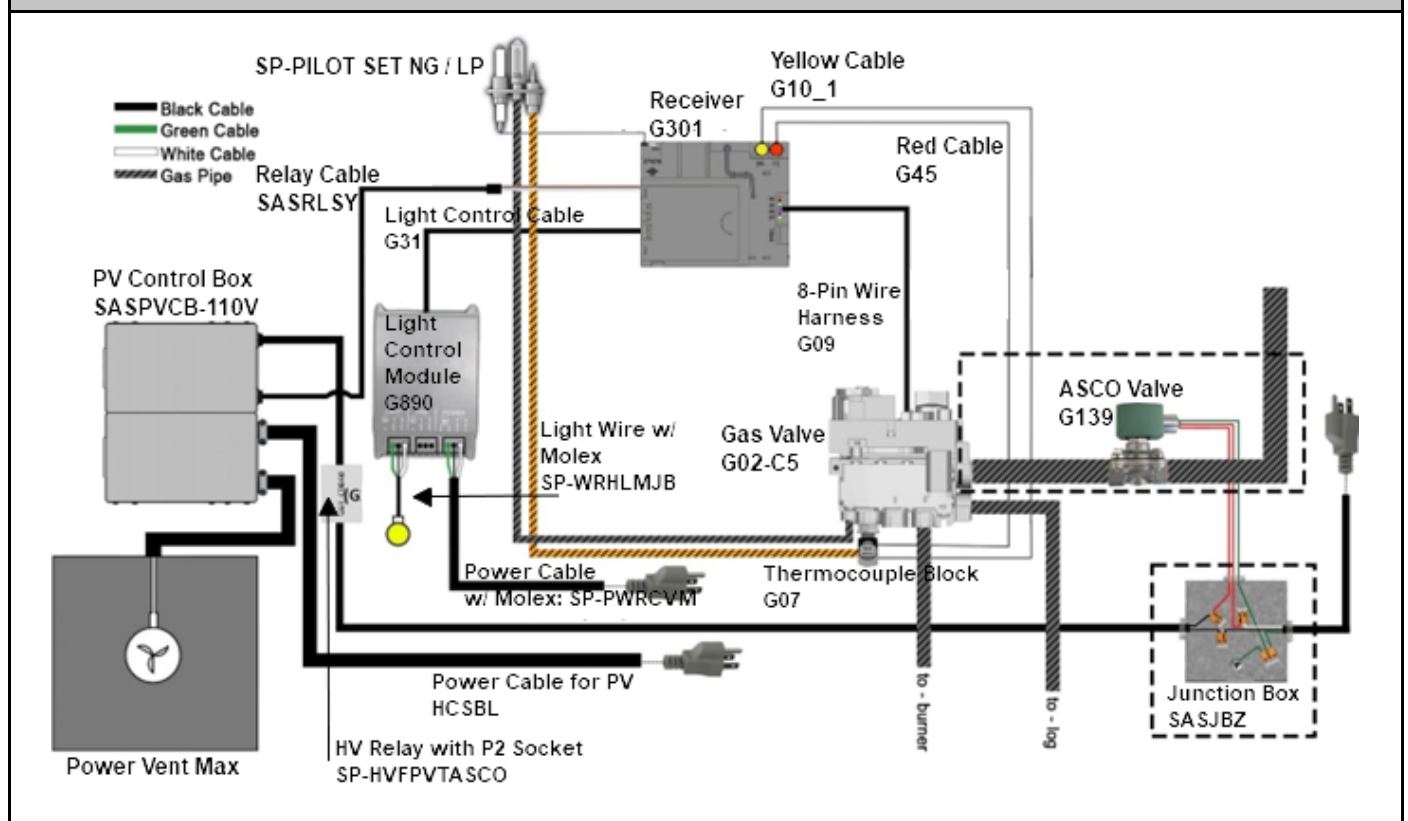

Wiring Diagram: Double Glass Fireplace with Interior Lighting and Power Vent Max

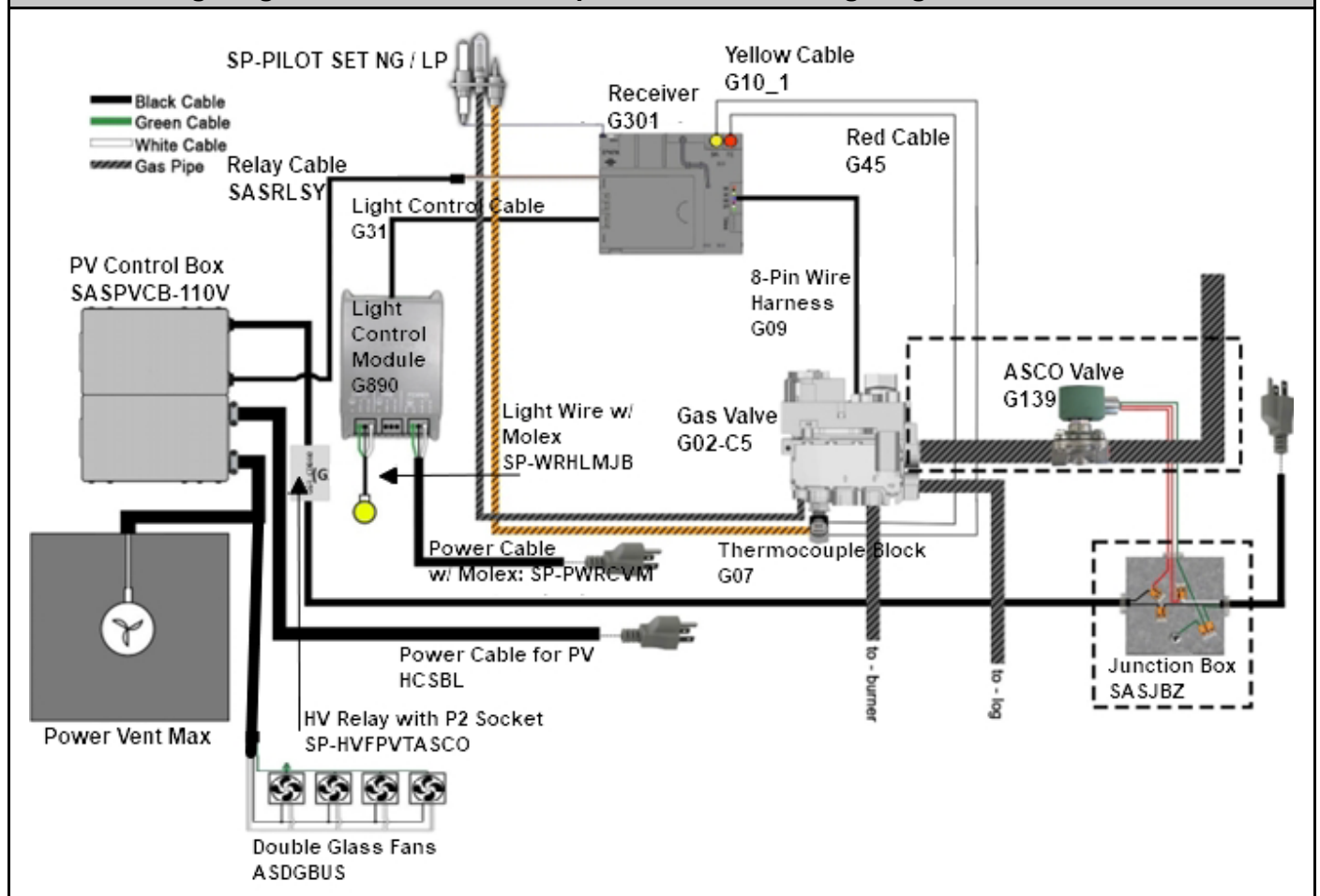

Home Automation Wiring Diagram

Use the following wiring diagram to connect fireplace control a hardwired home automation system.

Contacts Options/Operation

Ignition: Close contacts 0 (orange) and 2 (brown) simultaneously for 1 second. Fireplace automatically goes to high after ignition.

Up Flame: Close contacts 0 (orange) and 1 (red) simultaneously. The contact needs to be closed for 12 seconds to turn the motor from end-stop to end-stop.

Down Flame: Close contacts 0 (orange) and 3 (black) simultaneously. The contact needs to be closed for 12 seconds to turn the motor from end-stop to end-stop.

Off: Close contacts 0 (orange) and 2 (brown) simultaneously for 1 second.

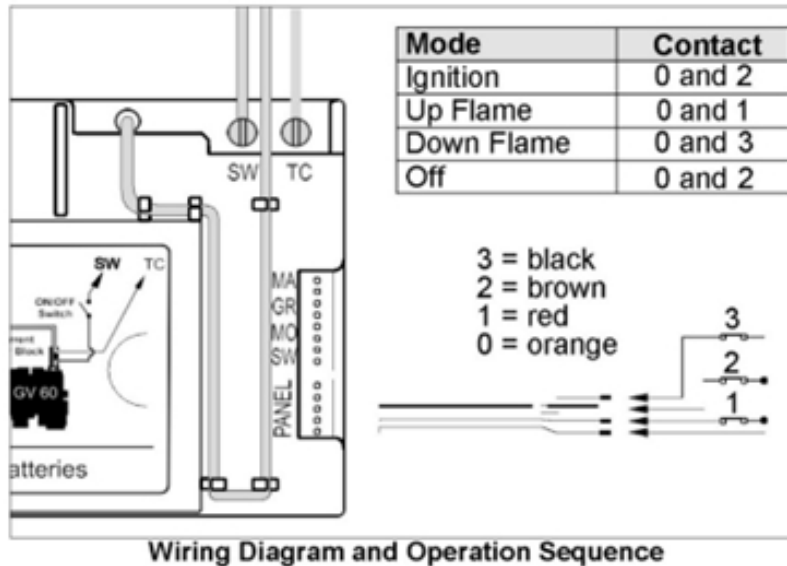

Mode of Operation: The external source provides ON and OFF operation only. The Timer/Thermostat handset provides all other functions.

NOTICE: The Timer/Thermostat handset in Thermostatic Model controls the room temperature even if the fire is turned on by the external source. If the handset is in Manual Mode, the fire will go to High Fire in the next cycle of external operation.

NOTE: This wiring diagram is for hardwired home automation systems only and will not connect the fireplace to a wireless system.

Driftwood Firelog Set

Wilderness Driftwood Firelogs are designed for use in the Wilderness series fireplaces only. No other interior design media options are permitted for Wilderness series fireplaces. The following Firelog sets are permitted for the Wilderness 77 series fireplaces:

Driftwood 135-3 Firelog Set for Wilderness 77 Series Fireplaces, NG to LP: **SKU: GCNLLDW3LB135O-US**

Driftwood 135-3 Firelog Set for Wilderness 77 Series Fireplaces, LP to NG: **SKU: GCLNLDW3LB135O-US**

DRIFTWOOD FIRELOG SETS ARE DIFFERENT FOR NG AND LP:

- Firelog sets for NG and LP have different SKUs. Please ensure you have the correct SKU for desired gas type prior to ordering.
- LP logs do not contain nickel strands inside the logs. NG logs do contain nickel strands.

NOTE: It can take up to 20 minutes for the flames to turn yellow.

WARNING: The fireplace is not designed to burn real wood. Any attempt to do so could cause irreparable damage to the fireplace and may result in property damage, personal injury and/or loss of life.

WARNING: To prevent log breakage, follow these log instructions carefully. The gas logs **MUST** be supported by additional logs as directed as they were not designed to support their own weight solely from the gas supply tube.

Firelog Installation Warnings

1. **Firelogs are fragile.** Handle them gently to prevent damage to their paint or to the fireplace.
 - **Arrange firelogs as shown in the section below.** Do not arrange them in any other way. If firelogs are not installed per installation instructions, flame impingement and improper combustion may occur and result in soot and/or excessive production of carbon monoxide (CO). Carbon monoxide is a toxic, colorless, and odorless gas.
 - **Do not install the firelog media until** fireplace installation is complete, the gas line is connected and tested for leaks, and initial burner operation has been inspected and approved.
 - **Keep 1 inch around the pilot (behind pilot hood) completely clear of any media or debris.** Contact between the nickel strands and the spark plug cable may lead to failure operating the fireplace.
 - **Do not cover the main burner holes** (marked in the image below) unless otherwise stated in this manual. Blocking the holes can cause a gas release that could cause hazardous pressure build-up in the fireplace.

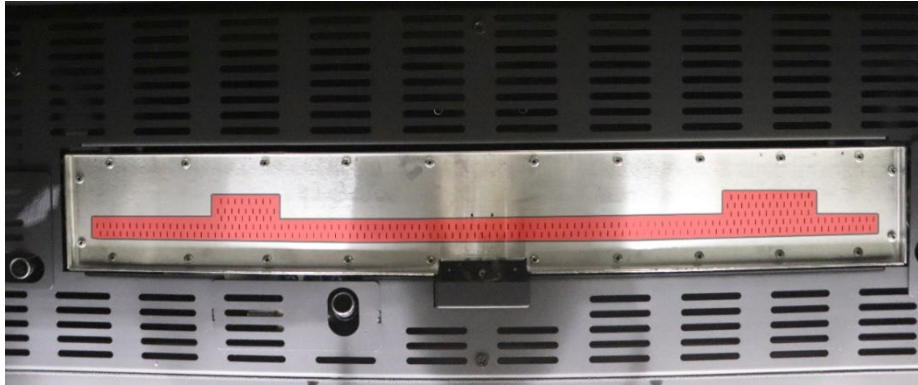

- **Placing the log onto the log base/tube:**
Step 1: Grasp the log at both ends as shown in the picture.



Step 2: Insert the tube coming out of the log into its base while making gentle rotational movements back and forth around its axis for easy insertion/removal. See figure below.

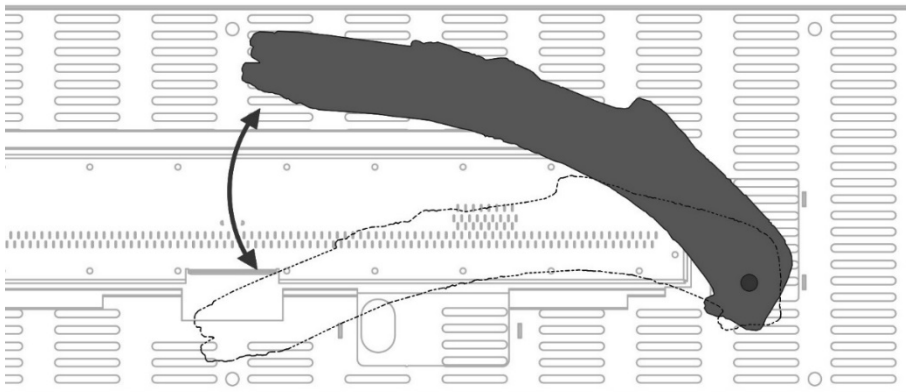

Top View

WARNING: Using force when installing the log onto its base/gas tube may result in breakage or damage to the log that will require its replacement.

Firelog Setup

Log placement of the Driftwood Firelog Set is crucial for optimal fireplace operation and safety purposes. Logs must be arranged as detailed in the following pages. No other arrangement is permitted. Alternative log arrangement will affect fireplace safety, operation, and performance. Setup can take up to 1 hour to complete. Handle logs gently to avoid paint damage. Log placement is the same for NG and LP.

The following items are included with the Driftwood Firelog set for the Wilderness 77 series fireplaces.



Items supplied with Driftwood Firelog set

STEP 1: Nickle Strands

1. Use your fingers to separate the nickel strands (supplied 2x20" long) as shown in the image below. It is recommended to cut the nickel strips into 10 equal strips to make it easier to separate them.



Left: Nickel strands as supplied | Right: Nickel strands ready to use

2. Place nickel strands on top of the burner holes. Keep nickel strands a minimum of 1 inch from the pilot.



⚠ WARNING: For safety and optimal fireplace function, keep 1 inch around the pilot (behind pilot hood) completely clear of any media or debris.

Arrange firelogs as shown in Steps 2-9.

STEP 2



STEP 3

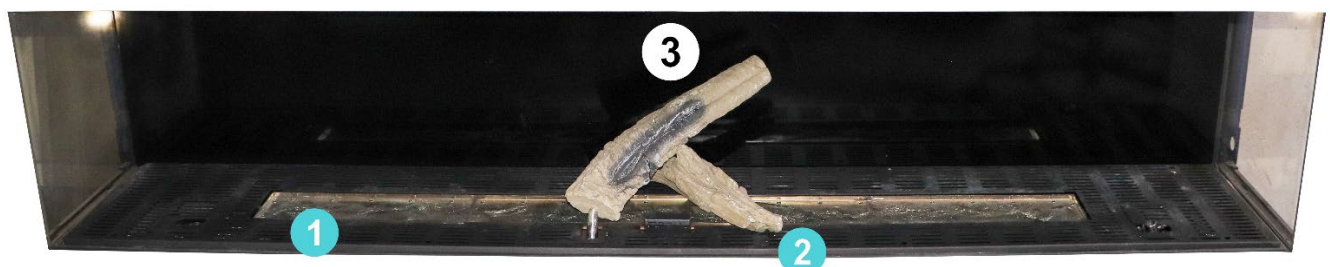

The base of log #3 can be adjusted to fit the position shown in the picture above (see "Log Base Position Adjustment" section on for details).

STEP 4



STEP 5



STEP 6



The base of log #6 can be adjusted to fit the position shown in the picture above (see “Log Base Position Adjustment” section for details).

STEP 7



The base of log #7 can be adjusted to fit the position shown in the picture above (see “Log Base Position Adjustment” section on for details).

STEP 8



STEP 9



STEP 10 : Charcoal

Cover the remainder of the burner with provided charcoals. Do not cover any burner holes. Maintain minimum 1-inch clearance around the pilot (behind pilot hood).



⚠ WARNING: For safety and optimal fireplace function, keep 1 inch around the pilot (behind pilot hood) completely clear of any media or debris.

⚠ WARNING: To prevent log breakage, follow these log instructions carefully. The gas logs **MUST** be supported by additional logs as directed as they were not designed to support their own weight solely from the gas supply tube.

Log Base Position Adjustment

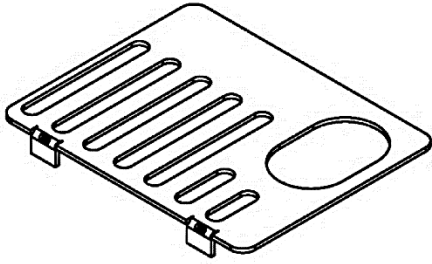

Left Grill Cover

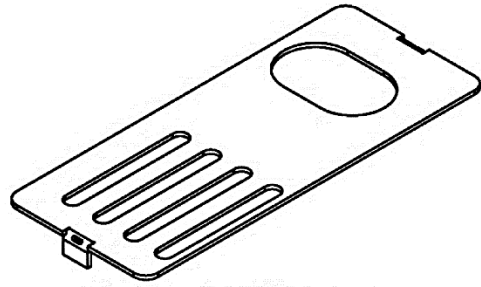

Center Grill Cover

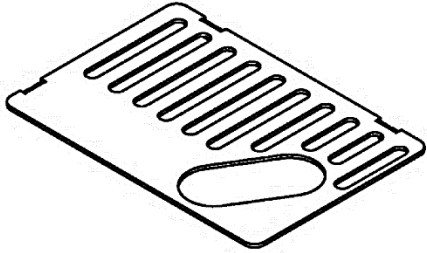

Right Grill Cover

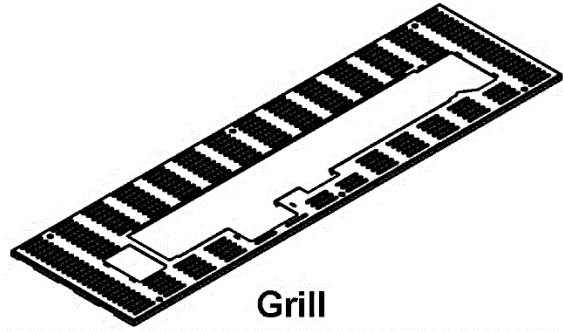

Grill

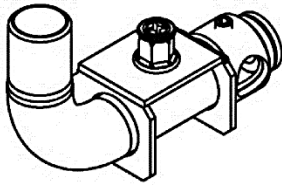

Left/Right Log Base

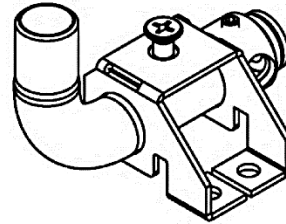

Center Log Base

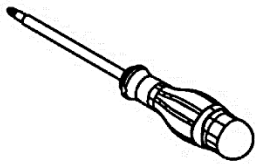

Phillips Head
Screwdriver



2.5 Allen Key

Tools Needed

Adjustment Instructions

! NOTE: The following images are for illustrative purposes only. Instructions apply to Front, Corner, and Three-Sided models.

Step 1

Remove the front heat barrier (screen or glass) and inner front glass.

Step 2

Pull the logs up and remove from the fireplace, as shown in figure 1 below.

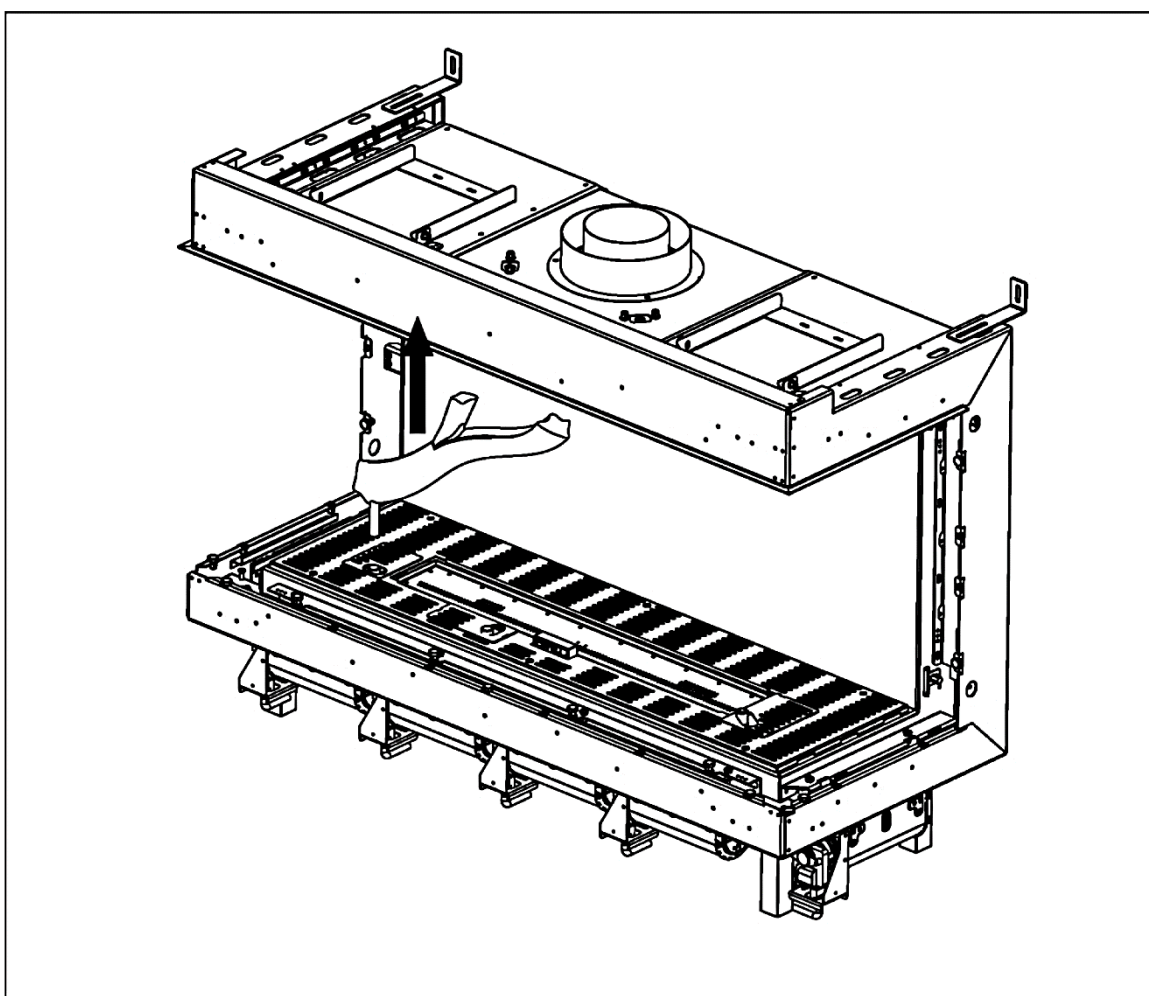

Figure 1

Step 3

Remove the grill covers as shown in figure 2 below.

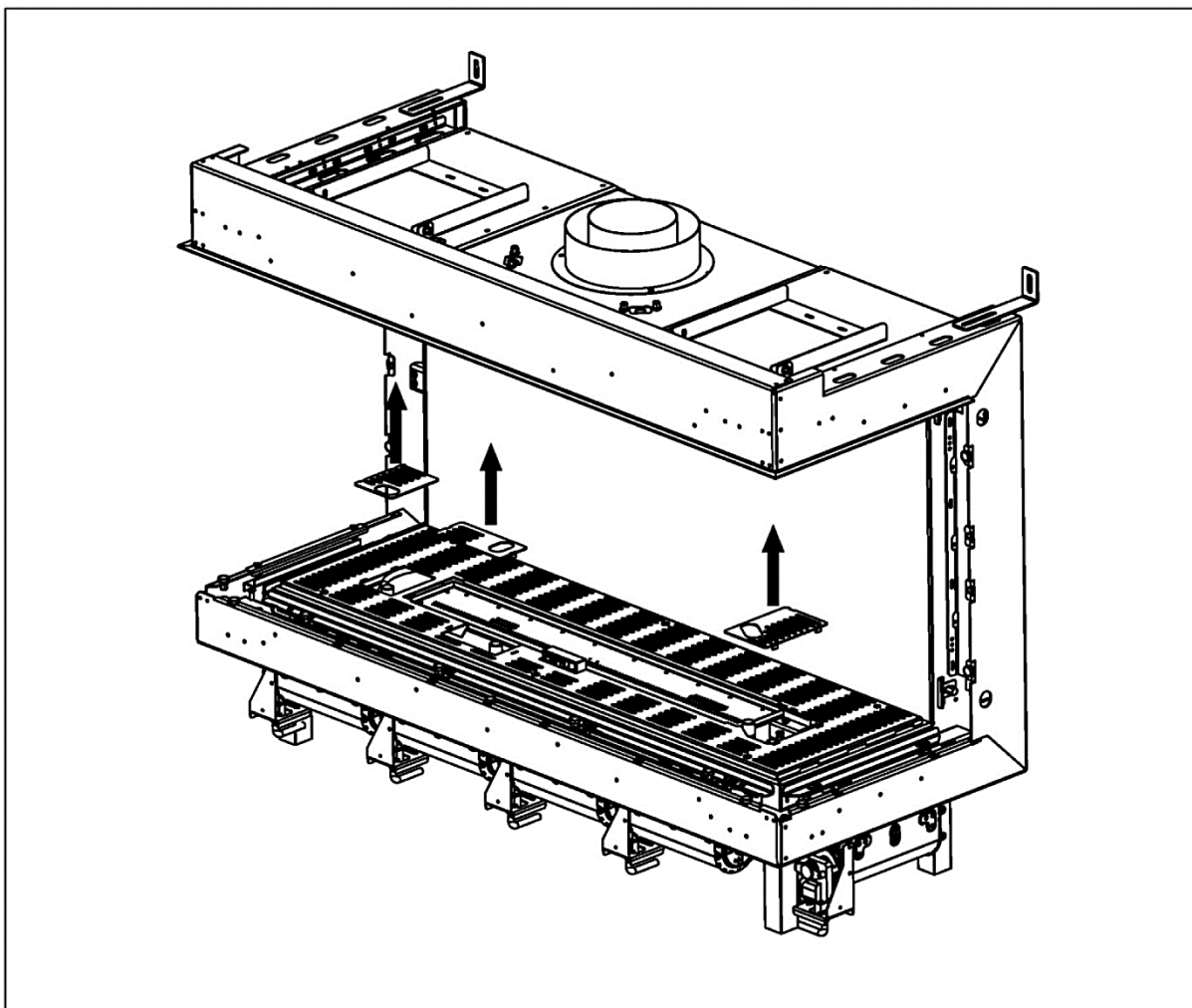

Figure 2

NOTE: Reassemble the system by performing Steps 1-3 in reverse.

Adjusting Log Position

Step 4

Using a screwdriver, loosen the log tube screw to change its orientation, as shown in figure 3 below.

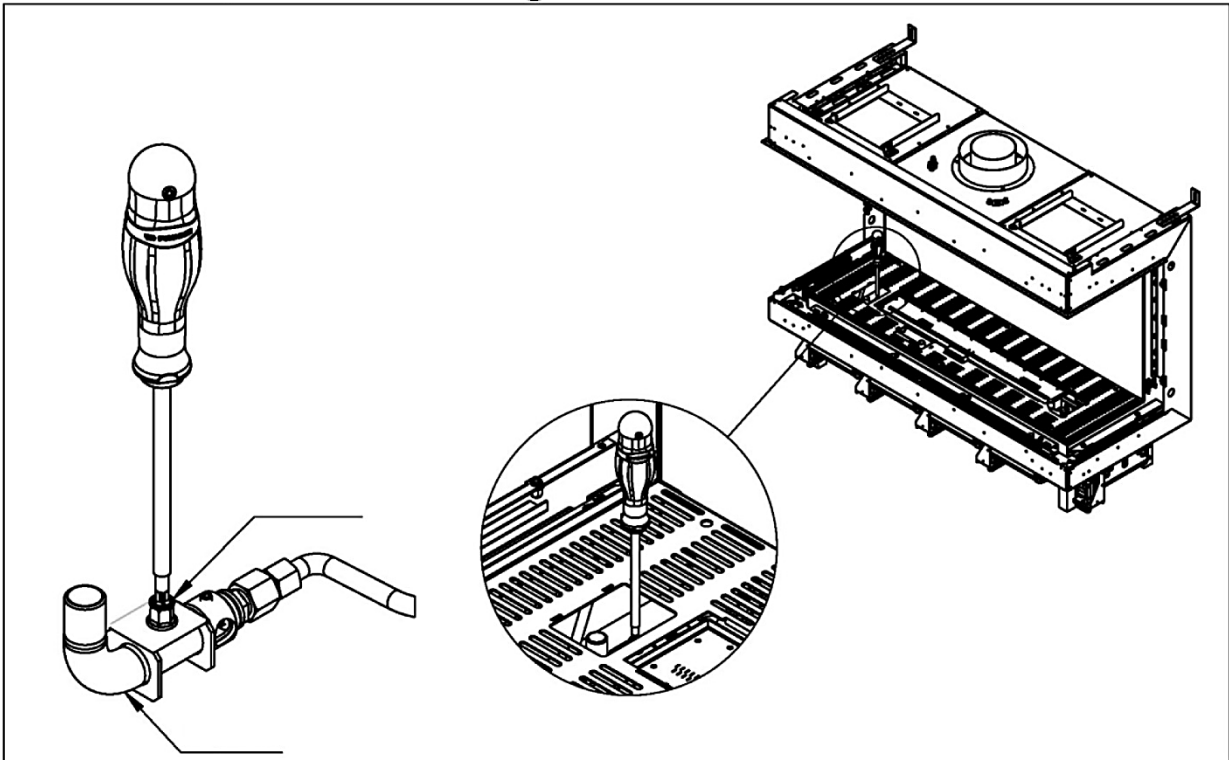

Figure 3

Step 5

Adjust the orientation as needed, as shown in figure 4 below, then re-tighten the screw.

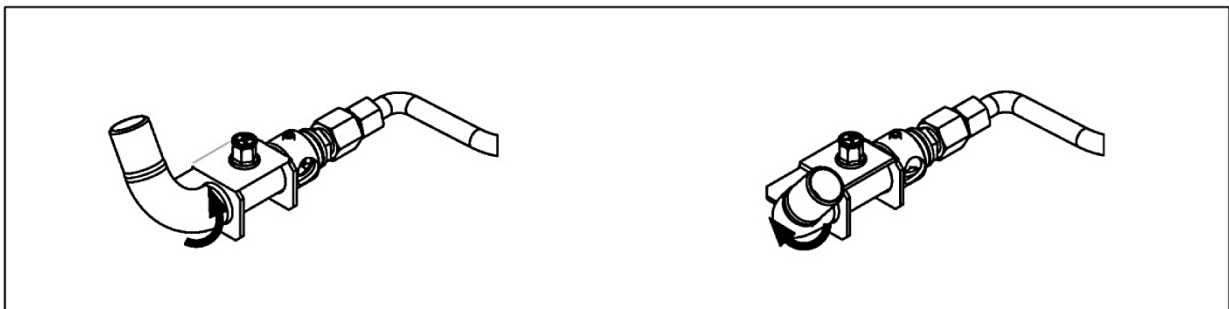

Figure 4

Log Base Aeration

Step 1

Using a 2.5mm Allen Key, loosen the aeration screw to change its position, as shown in figure 1 below.

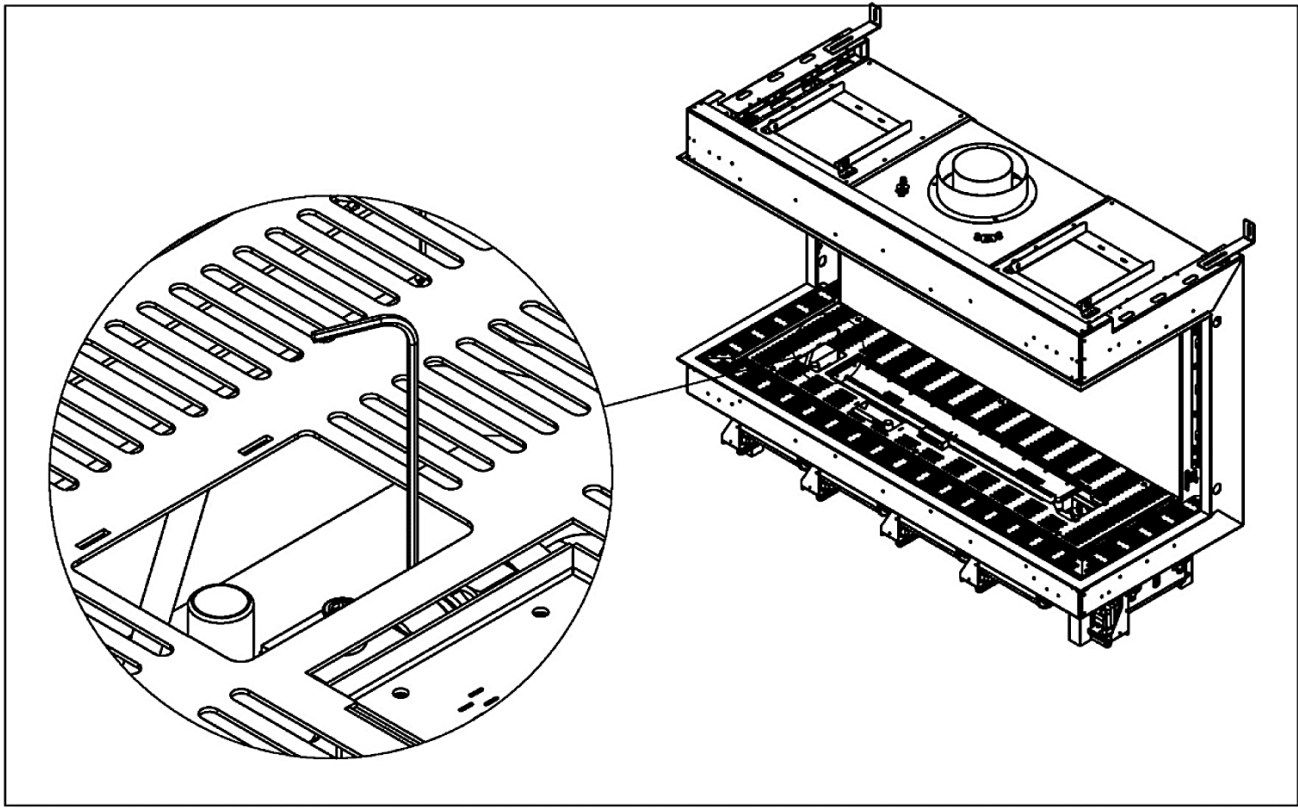

Figure 1

Step 2

Rotate the shutter to adjust the aeration to the gas tube, as shown in figure 2 below. Then re-tighten the screw.

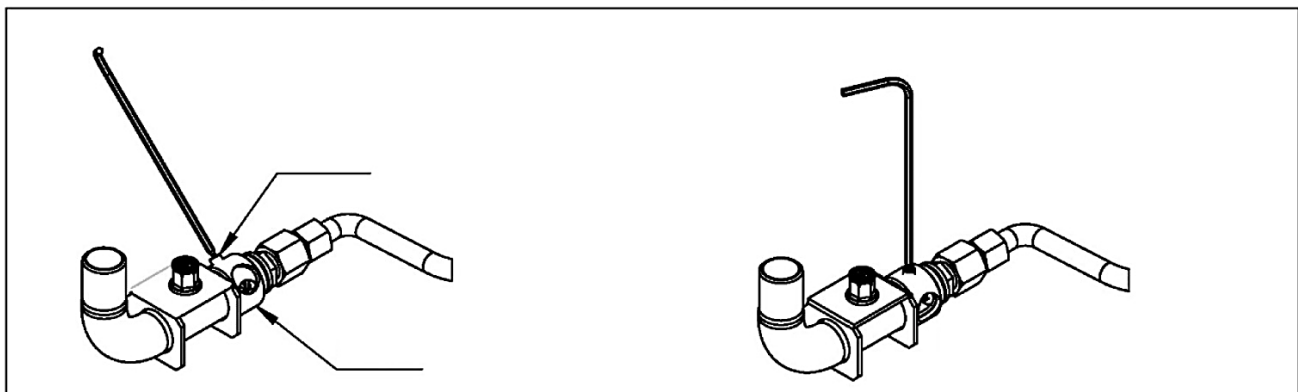

Figure 2

Operation

WARNING – Read these instructions carefully before lighting the fireplace.

Four operation options are available for use with the fireplace:

- 10-Button Remote Control Handset (default option, always included with the fireplace)
- Puck Handset (optional accessory)
- Wall Switch (optional accessory)
- MyFire Application (optional accessory)

IMPORTANT: The 10-Button remote control handset is always included with the fireplace regardless of which operation option is chosen. **DO NOT DISCARD.** The 10-Button remote must be kept within 26 feet of the fireplace at all times.

NOTES:

- Wiring of valve and receiver must be completed before starting ignition. Failure to do so could damage the electronics.
- Fireplaces with double glass, power vent, and/or interior lighting features must operate using the AC Adapter and therefore will not operate during a power failure.
- Only the Mertik Maxitrol AC Adapter is permitted for use with the fireplace. Use of other adapter brands can render the system inoperable. The handsets, receivers, wall switches are not interchangeable with other electronics.
- Batteries must be kept within their recommended temperature limits (32°F to 131°F).

10-Button Remote Control Handset

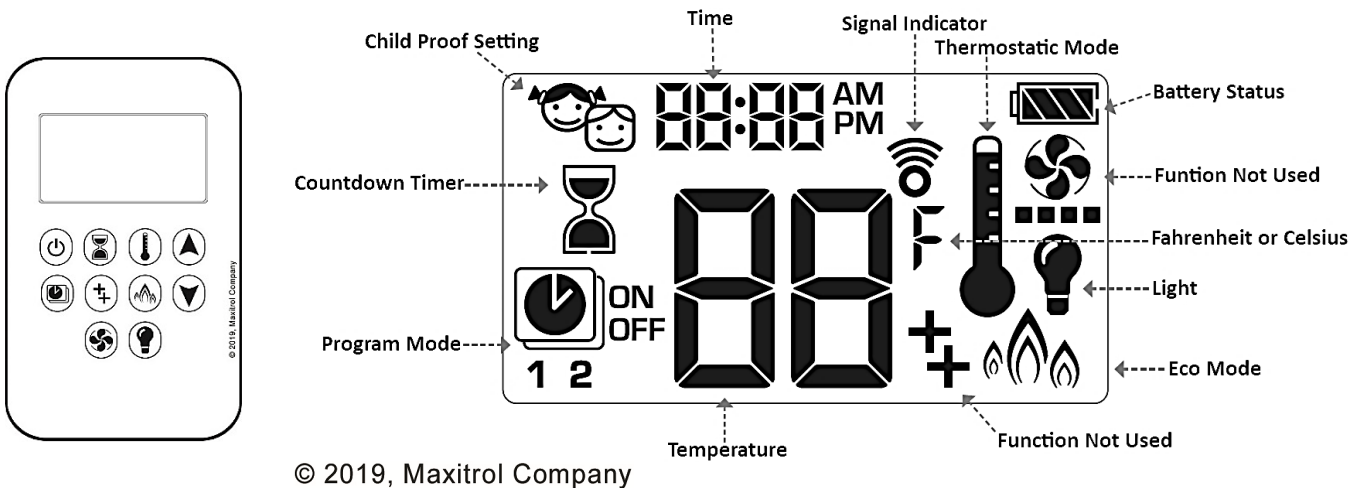

Control Option	Radio Frequency	Power Supply	
		10-Button Handset	918.0 MHz (U.S. & Canada)

IMPORTANT: For safety/communication purposes, 10-button handset must be located within 26 feet of the receiver.

NOTE: Any device that functions using the same radio frequency as the handset will be affected when handset is in use.

Operating Instructions

Instructions for operating the 10-Button Handset are shown below. For more in-depth instructions, please refer to the “Homeowner’s Fireplace Operation Manual” or “Remote Operation Instructions”.

NOTE: Some options on the remote may not be available for all fireplaces.

Turning the Fireplace On

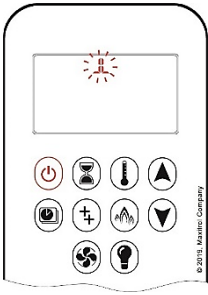

1. Press the  button until you hear continuous beeping, and a blinking series of lines confirms the start sequence has begun; release buttons.
2. Main gas flows once pilot ignition is confirmed.
3. The system automatically goes into Manual Mode after main burner ignition.

NOTE: When pilot ignition is confirmed, motor turns automatically to maximum flame height.

NOTE: If the Timer function has been set and the fireplace is manually turned on, the Timer function will need to be reset.

Turning the Fireplace Off





1. Press the  button to turn the fireplace off.

NOTE: The fireplace may be turned on again after the OFF icon stops flashing.

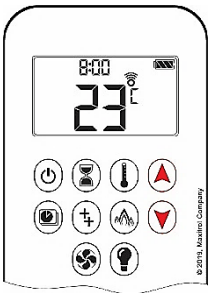
Flame Height Adjustment



1. To increase flame height, press and hold the  button to desired flame height.
2. To decrease flame height, or to set fireplace to pilot flame only, press and hold the  button.

Puck Handset

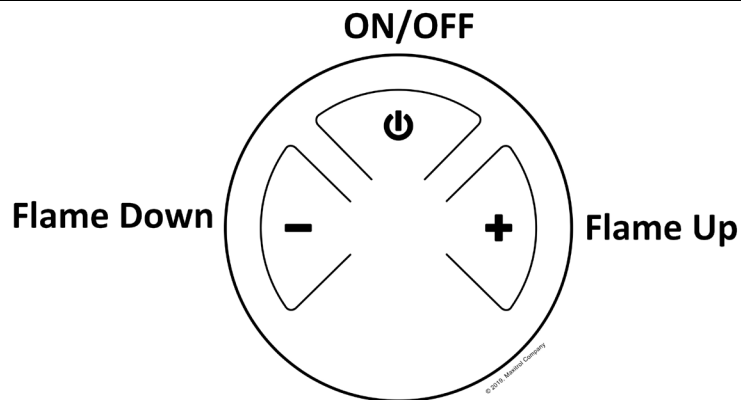

Control Option	Radio Frequency	Power Supply	
Puck Handset	918.0 MHz (U.S. & Canada)	2 x 1.5V AAA batteries (Quality alkaline recommended)	Replace batteries after 2 years or when low battery indicator appears on handset display

IMPORTANT: For safety/communication purposes, Puck handset must be located within 26 feet of the receiver.

NOTE: Any device that functions using the same radio frequency as the handset will be affected when handset is in use.

Operating Instructions

Instructions for operating the Puck Handset are shown below.

Turning the Fireplace On/Off

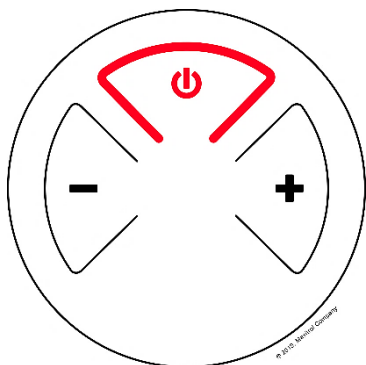

ON:

- Firmly press and hold the  button until two short beeps confirms the start sequence has begun; release button.

OFF:

- Firmly press the  button.

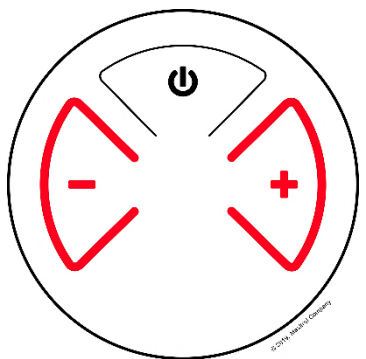

Increase/Decrease Flame Height



INCREASE:

- To increase flame height, press and hold  button.

DECREASE:

- To decrease flame height, press and hold  button.
- Holding the  button long enough sets the fireplace to pilot flame (Standby Mode).

Designated Flame Settings

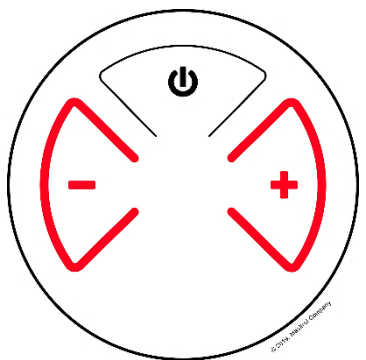

DESIGNATED LOW FLAME SETTING

- To go to designated low flame setting, double-click  button.

 **NOTE:** Flame goes to High Flame before going to Low Flame.

DESIGNATED HIGH FLAME SETTING

- To go to designated high flame setting, double-click  button.

Wall Switch

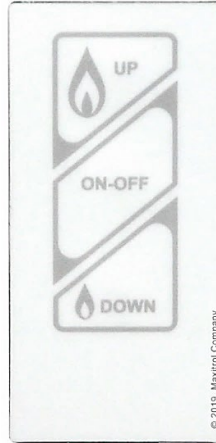

Control Option	Radio Frequency	Power Supply
Wall Switch	N/A	N/A
IMPORTANT: For safety/communication purposes, the 10-button handset must be located within 26 feet of the receiver.		

Operating Instructions

Turning the Fireplace On/Off



ON/OFF

ON: Press and hold the **ON-OFF** button until two short beeps confirms the start sequence has begun; release button.

OFF: Press the **ON-OFF** button.

Flame Height Adjustment



Flame Up

Flame Down

INCREASE: To increase flame height, press and hold  (up flame) button.

DECREASE: To decrease flame height, press and hold  (down flame) button.

Holding the  (down flame) button long enough sets the fireplace to pilot flame (Standby Mode).

Fireplace Maintenance

General Maintenance

All servicing, maintenance, interior cleaning and handling of the fireplace, parts and glass must be performed by an authorized Ortal dealer service technician only.

Servicing

- Turn off the gas and electricity **BEFORE** servicing the fireplace.
- It is recommended that a routine inspection is performed at the beginning of each heating season.
- When removing glass from multisided fireplaces, only one side of glass can be removed at a time. Glass must be re-installed before removing glass from a different side.

Metallic Noise

- Noise is caused by metal expanding and contracting as it heats up and cools down, like noise produced from a furnace. The noise does not affect the operation or longevity of the fireplace.
- These minor expansion, contractions or movement of parts causing noise are normal. Complaints related to these noises are not covered by warranty.

Burner and Vent Inspections

- Periodic checks should be made of the burner for correct position and condition. Visually check the flame of the burner, making sure that the flames are steady.
- The vent system must be inspected before use. Annual inspection must be scheduled to ensure the flow of combustion and ventilation air.

Submerged Parts

- Do not use the fireplace if any part has been under water, or if you suspect that it may have been under water. The Ortal dealer service technician must inspect and, if necessary, replace any parts of the control system and any gas controls which have been under water.

Handling the Glass

Inner glass panel is 5mm ceramic glass. Exterior double glass panel is 3/16" tempered glass. Tempered glass can be sourced locally if replacement becomes necessary. Ceramic glass must be provided by Ortal.

- When removing glass from multisided fireplaces, only one side of glass can be removed at a time. Glass must be re-installed before removing glass from a different side.
- **NEVER** operate the fireplace without the glass properly secured in place.
- Only an Ortal certified installer is authorized to remove the glass. Glass must be removed using an 8-inch glass-handling suction cup. Lower the glass to rest in a safe place to prevent damage to the glass edges.

Cleaning the Fireplace

- Only an Ortal dealer service technician can open the fireplace to clean interior surfaces.
- **ALWAYS** turn off the gas valve before cleaning.
- Do **NOT** clean when hot. Make sure fireplace has had time to cool prior to cleaning any surface or component, interior or exterior.
- Keep the fireplace clean by brushing and/or vacuuming at least once a year. This can only be performed by an Ortal dealer service technician.
- When removing glass from multisided fireplaces, only one side of glass can be removed at a time. Glass must be re-installed before removing glass from a different side.
- Clean the glass when it starts to look cloudy. Use a damp cloth for cleaning the fireplace and the door.
- Verify correct operation after servicing.

Maintenance Frequency and Equipment Checklist

- Under normal circumstances, the factory recommendation is to have the fireplace serviced at least once a year. Fireplaces meeting the following conditions should have more frequent service:
 - Fireplaces installed in commercial/public spaces should be serviced every 3 months.
 - Fireplaces installed in climates near the ocean or in other settings where corrosion buildup is more likely should be serviced every 6 months.
- Thermocouple Maintenance:
 - The thermocouple should be replaced annually or as needed in all commercial installations, and in any residential fireplace where the fireplace is operated for an average of 10 hours or more per day.
 - For all other installations, the thermocouple should be replaced every three years or as needed.

© Ortal 2026
Version 2.4, March 2026
SKU: KPMANWILD77V2.4

Ortal USA
2152 Citygate Dr., Columbus, OH 43219
T: (818) 238-7000 | F: (818) 678-0541
info@ortalheat.com | www.ortalheat.com