

ORTAL®

Installation and Operation Manual Wilderness Outdoor 44 Series

! DANGER

HOT GLASS WILL CAUSE BURNS.

DO NOT TOUCH GLASS UNTIL COOLED

NEVER ALLOW CHILDREN TO TOUCH GLASS.

A barrier designed to reduce the risk of burns from the hot viewing glass is provided with this appliance and must be installed for the protection of children and other at-risk individuals

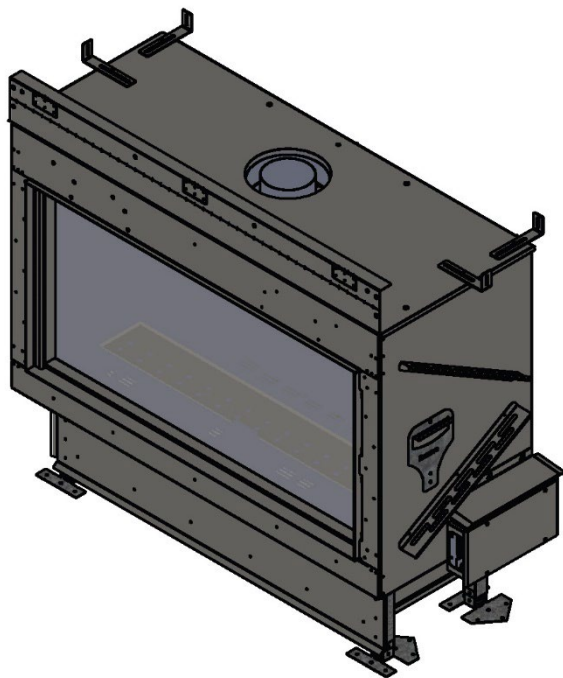

⚠ DANGER
FIRE OR EXPLOSION HAZARD

If you smell gas:

- Shut off gas to the appliance.
- Extinguish any open flame.
- If odor continues, leave the area immediately.
- After leaving the area, call your gas supplier or fire department.

Failure to follow these instructions could result in fire or explosion, which could cause property damage, personal injury, or death.

⚠ WARNING

Do not store or use gasoline, or other flammable vapors and liquids, in the vicinity of this or any other appliance.

An LP-cylinder not connected for use shall not be stored in the vicinity of this or any other appliance.

⚠ WARNING: For Outdoor Use Only.

Installation and service must be performed by a qualified installer, service agency, or the gas supplier.

INSTALLER: Leave this manual with the appliance.

CONSUMER: Retain this manual for future reference.

⚠ DANGER

CARBON MONOXIDE HAZARD

This appliance can produce carbon monoxide which has no odor.

Using it in an enclosed space can kill you.

Never use this appliance in an enclosed space such as a camper, tent, car or home.

⚠ WARNING: If the information in this manual is not followed exactly, a fire or explosion may result causing property damage, personal injury, or loss of life.

Wilderness 44 Outdoor Series:
Wilderness 44H Front Facing



Safety Information and Warnings

IMPORTANT NOTE: LOCAL CODE

Local codes and regulations that are more stringent than the requirements in this manual take precedence over Ortal requirements.

WARNING: REVIEW ALL WARNINGS

Be sure to review all safety warnings and installation guidelines contained in this manual. Consider installation location, vent configuration, clearances, structural requirements, framing and finish materials, and local codes. ALL warnings and instructions apply to all products manufactured and distributed by Ortal.

WARNING: DO NOT OPERATE FIREPLACE IF:

The glass is NOT properly secured in place; Connection points are not sealed (for fireplaces with glass-to-glass connections); Glass is cracked; You smell gas; Any part of the fireplace has been under water; You have any doubt about safe operation of the fireplace. Immediately call a qualified, professional service technician to inspect the fireplace and to replace any parts of the control system and any gas controls which have been underwater.

WARNING: ELECTRICAL GROUNDING

All electrical connections must be properly installed, insulated, and secured to avoid potential **ELECTRICAL SHOCK** and **FIRE HAZARD** and malfunction of the system. Consult local building code requirements. In the absence of local codes, refer to the National Electric Code, ANSI/NFPA 70, or the Canadian Electric Code, CSA C22.1.

WARNING: MATERIAL USAGE

All materials and objects used to carry out the installation must be certified/approved or specified by Ortal and are suitable for use. Do NOT install the system with different materials or objects than those approved for installation by Ortal.

WARNING: INSTALLATION AND SERVICE

Installation and repairs on the fireplace and vent system must be done by an authorized Ortal qualified installer service agency or gas supplier. If these components are not installed by an authorized Ortal dealer/installer, the warranty of all components will be void and Ortal will not be responsible for any damage caused by improper installation. The fireplace should be inspected before use and at least annually by a professional service person. More frequent cleaning may be required due to excessive lint from carpeting, bedding material, etc. Control compartments, burners and circulating air passageways of the fireplace must be kept clean. Any alteration to the product can cause soot or carbon to form and may result in damage. This damage and any other damage that results from not following the instructions outlined in this manual is not the responsibility of Ortal.

WARNING: HEAT BARRIER

A barrier designed to reduce the risk of burns from hot viewing glass is provided with this fireplace and shall be installed. The fireplace MUST not be used without the heat barrier in place. If the barrier becomes damaged, the barrier shall be replaced with the manufacturer's barrier for this fireplace. **Any safety screen, guard, or barrier removed for servicing the fireplace must be replaced before operating.**

WARNING: FIREPLACE TEMPERATURE

Due to hot temperatures, the fireplace should be located out of traffic and away from furniture and draperies. Children and adults should be alerted to the hazards of high surface temperature and should stay away to avoid burns or clothing ignition. Clothing or other flammable material should not be placed on or near the fireplace. **Young children should be carefully supervised when they are in the same room as the fireplace.** Toddlers, young children, and others may be susceptible to accidental contact burns. A physical barrier is recommended if there are at-risk individuals in the house. To restrict access to a fireplace or stove, install an adjustable safety gate to keep toddlers, young children, and other at-risk individuals out of the room and away from hot surfaces.

WARNING: GLASS HANDLING

Only an Ortal certified installer is authorized to remove the glass using an 8-inch glass-handling suction cup.

WARNING: INSTALLATION AND OPERATION

The fireplace and accompanying components must be installed as an OEM installation in manufactured homes (USA only) or an aftermarket permanently located, or a mobile home, where not prohibited by local codes. The fireplace must be installed in accordance with the Manufacturer's instructions and the Manufactured Home Construction and Safety Standard, Title 24 CFR, Part 3280, in the United States, or the Standard for Installation in Mobile Homes, CAN/CSA Z240 MH Series, in Canada. **Exceeding the restrictions imposed in these instructions may result in a fire or explosion, causing property damage, personal injury, or loss of life. Ortal will not be responsible for any damage caused by improper installation. Do not store or use gasoline or other flammable vapors and liquids near this fireplace.**

WARNING: GAS FIREPLACE

This fireplace is for use only with the type of gas indicated on the rating plate. Solid fuels shall not be burned in this appliance. These fireplaces are not convertible for use with other gases unless a certified kit is used, and the conversion is performed by an authorized and qualified technician. Applicable standards approved to ANSI Z21.97- 2017/CSA 2.41 standards.

WARNING: CALIFORNIA PROP 65

These products and the fuels used to operate these products (liquid propane or natural gas), and the products of combustion of such fuels, can expose you to chemicals including benzene, carbon monoxide, and ceramic fibers, which are known to the state of California to cause cancer and/or reproductive harm. For more information, visit www.p65warnings.ca.gov.

Table of Contents

General	2
Safety Information and Warnings	2
Product Information	4
Models	4
Certification	4
Rating Label	5
Parts of the Fireplace	6
Installation	7
Prior to Installation	7
Locate the Fireplace	7
Fireplace Installation	7
Planning	7
Installation	7
Startup	8
Post-Installation	8
Initial Burning Period	8
Final Inspection Procedure	8
Final Checks and User Instruction	8
Building Around the Fireplace	9
→Building Checklist	9
Framing	10
Framing Requirements	10
Weather Proofing	10
Chase Floor/Leg Height	10
Minimal Framing Dimensions	11
General Clearances	13
Air Intake Openings	14
Access Panel	15
Finishing	15
Flush Installation	15
Recessed Installation	16
Maximum Overhang/ Mantel Depth	16
Venting	17
General Venting Requirements	17
Vent Configurations	17
Vent Restrictor Sizing Guidelines	19
Clearances	19
Termination	20
Horizontal Termination Clearance Diagram	20
Vertical Termination Clearance Diagram	22
Vent Installation	23
Vent Maintenance	23
Gas	23
Gas Pressures	23
Routing the Gas Line	23
Gas Conversion	24
High Altitude Requirements	24
Electrical	24
Electrical Requirements	24
Pairing the Remote and Receiver	24
Wiring Diagram	25
Replacement Parts	25
Firelog Installation Warnings	26
Driftwood Firelog Set	27
Driftwood Firelog Setup	28
Valley Oak Firelog Set	32
Valley Oak Firelog Setup	33
→Birch Log Firelog Set	37

→Birch Log Firelog Setup	37
Log Base Position Adjustment	42
Servicing the Fireplace	46
Screen Removal	46
Glass Removal	48
Service Box	50
Service Box Installed on the Side	50
Service Box Installed Underneath the Burner	51
Operation	53
10-Button Remote Control Handset	53
Operating Instructions	54
Wall Switch	54
Operating Instructions	55
Fireplace Maintenance	56
General Maintenance	56

Product Information

Models

Series	Models	Firelog Burner	Certification Standard	Gas Types	Direct Venting
Wilderness Outdoor 44	Wilderness 44H Front	Driftwood, Valley Oak or Birch Firelogs (BL70)	US: ANSI Z21.97-2017 Canada: CSA 2.41-2017	Natural Gas or Propane	Standard: Type: Passive Vent Vent Size: 5"x8" (co-axial)

NOTES:

- Venting is not supplied by Ortal with the fireplace. The fireplace is certified to be used with, and can be obtained from, the vent manufacturers outlined in "General Venting Requirements" section.
- Not for use with a Power Vent.

Certification

These outdoor fireplaces are tested and approved to ANSI Z21.97- 2017/CSA 2.41 standards by PFS agency using listing #20-024. It should be installed by a qualified installer in accordance with local and state building codes using National Fuel Gas Code ANSI Z223.1/ NFPA54 or current CSA-B149.1 installation codes for Gas Burning Appliances and Equipment in Canada.

CSA Group is approved by the American National Standards Institute (ANSI) as an Accredited Standards Developer.

Certification Standard:

US: ANSI Z21.97 – Outdoor Decorative Gas Appliance
Canada: CSA 2.41 – Outdoor Decorative Gas Appliance



The fireplaces are permitted for outdoor use only. An outdoor space is defined as the following per ANSI Z21.97: Outdoor spaces- An appliance is considered to be outdoor if installed with shelter no more inclusive than:

- With wall on all sides, but no over- head cover.
- Within a partial enclosure with includes an overhead cover and no more than two side walls. These side walls may be parallel, as in a breezeway or at right angles to each other; or
- Within a partial enclosure which includes an overhead cover and three sidewalls, as long as 30% or more of the horizontal periphery of the enclosure is permanently open.

IMPORTANT:

- Consult the authority having jurisdiction to determine the need for a permit prior to starting the installation.
- It is the responsibility of the fireplace dealer and installer to ensure that this fireplace is installed and framed in compliance with these instructions and all applicable codes.
- Before starting, take careful note of **ALL** the **WARNINGS** in this manual.

Rating Label



The fireplace rating label is found on a metal plate separate included with the fireplace.

DEALERS/INSTALLERS:

You **MUST** leave the fireplace's rating label with the fireplace in an area easily accessible by the owner (typically near the access panel, if available). You must instruct the owner before handing over the fireplace where this label can be found.

OWNERS:

Make sure the installer leaves your fireplace's rating label in an area that is easily accessible for you. This information is required for servicing and receiving replacement parts.

ORTAL [®]		  	
Manufacturer/Fabricant Ortal Ltd. 14 Haharash St. Hod Hasharon, 4524087 Israel Tel: 011-972-9-7402828 Fax: 011-972-9-7402687		For use only with vent, glass and interior design media certified and approved for use with the appliance. Not for use with solid fuel. For use only with barrier(s) Part No(s) _____ Follow installation instructions.	
<input type="checkbox"/> ORTAL <input type="checkbox"/> LYRIC		Utilisez uniquement avec des conduits, des panneaux vitrés et des accessoires décoratifs intérieurs homologués et approuvés pour une utilisation avec cet appareil. Pas pour l'usage avec le combustible solide. À utiliser uniquement avec la ou les barrière(s) numéro(s) de pièce _____ Suivez les instructions d'installation.	
Serial No.:	<input type="text"/>	Approved By: Homologué Par:	CSA No.: 2358468
Tested to: CSA/ANSI Z21.97-2017 • CSA 2.41-2017 for Outdoor decorative gas appliances Examiné à: CSA/ANSI Z21.97-2017 • CSA 2.41-2017 pour Appareils décoratifs extérieurs au gaz			
Altitude rating: Estimation d'altitude:	0-2000 ft. / 0-610 m.	Electrical Rating: Estimation Électrique:	120 volt / 60 Hz / less than 5A
Model Series / Modèle Séries: Wilderness Outdoor Burner 70-3			
<input type="checkbox"/> Wilderness Outdoor 44 H/HH FR/TU <input type="checkbox"/> Wilderness Outdoor Traditional 36 <input type="checkbox"/> Wilderness Outdoor 60 H/HH FR/TU <input type="checkbox"/> Wilderness Outdoor Traditional 42			
For Outdoor Use Only / Seulement pour usage extérieur			
Fuel Type/Type de combustible:	<input type="checkbox"/> NG/GN		<input type="checkbox"/> PROPANE
Max Input / Débit max. (BTU/HR):	33,500		29,000
Min Input / Débit min. (BTU/HR):	15,696		21,400
Orifice Size / Taille de l'orifice:	320-160-320 380		90-60-90 180
Gas Inlet Pressure (W.C.) inches: Pression d'entrée de gaz (CE) pouces:	Min.: 7.0	Max.: 11.0	Min.: 11.0 Max.: 13.0
Gas manifold Pressure (W.C.) inches: Pression d'alimentation (CE) pouces:	4.7		4.7
Clearances to Combustibles (with included standoffs): Espacement par rapport aux matériaux inflammables (avec entretoises inclus):	Sides: Côtés: 0"	Back: Arrière: 0"	In front of Glass Devant le panneau vitré: 16"
Also adhere to clearance diagrams and instructions included in the ORTAL manual. Adhérer également aux schémas d'espacement et des instructions figurant dans le manuel ORTAL.			
High Altitude Installations / Installations en haute altitude			
• In the USA: Reduce input rate 4% for each 1000 feet above 2000 feet. • In Canada: For altitudes 2,000-4,500 feet the 10% input rate reduction should be used. NG: Input: 7.0 Manifold pressure: 4.0 Orifice: 320-160-320+380 PROPANE: Input: 11.0 Manifold pressure: 4.2 Orifice: 90-60-90+180 For operation above 4500 feet refer to B149 • Aux États-Unis : Réduisez le débit d'entrée de 4 % tous les 305 mètres au-dessus de 610 mètres. • Au Canada : Pour les altitudes de 610 à 1,370 mètres, la réduction du débit d'entrée de 10 % doit être utilisée. GN: Débit: 7.0 Pression d'alimentation: 4.0 Orifice: 320-160-320+380 PROPANE: Débit: 11.0 Pression d'alimentation: 4.2 Orifice: 90-60-90+180 Pour une utilisation au-dessus de 1,370 m, consultez B149.			
SKU: M209-WDOD-70-3			

Wilderness 44 Series Rating Label

Parts of the Fireplace

Side & Back Framing Stand-offs: Attached to the sides and back of the fireplace, keeping enough distance from the fireplace to the framing to allow for proper airflow inside the chase.

Top Framing Stand-offs: Keeps a clearance above the heat barrier vents on the top of the fireplace to ensure proper air flow inside the chase.

Service Box: Attaches to either the sides or underneath the fireplace. It houses the electrical components for weatherproofing protection.

Rain Cover: Encloses the firebox, to assist with proper airflow and keep the fireplace weatherproof.

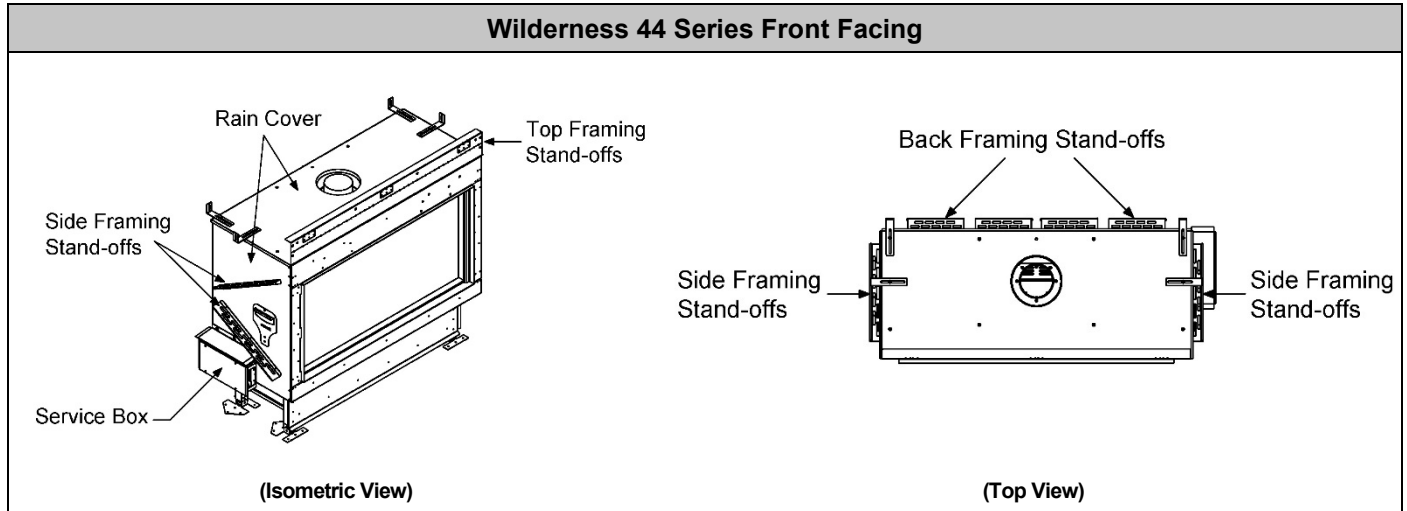

Airflow

The diagram below depicts the airflow through the fireplace from the air intake.

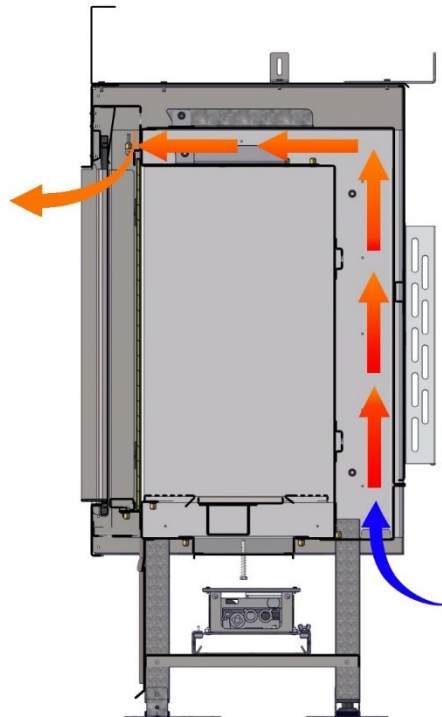

Installation

Prior to Installation

Locate the Fireplace

Keep the following factors in mind when selecting a location for the fireplace:

- Fireplace clearance requirements
- Adequate space for servicing.
- Access panel, depending on location of service box
- Minimum vertical vent rise, allowed horizontal lengths, and number and orientation of elbows
- Framing and finishing requirements
 - Front wall installation and finishes to be completed after fireplace and vent installation
- Floor requirements

Fireplace Installation

Use the following guidelines to ensure smooth installation. The installation sequence is divided into three phases: Planning, Installation, and Startup.

Planning

Consult with the contractor and go over all requirements:

- Chase framing requirements, including weatherproofing
- Air Intake requirements and weatherproofing
- Service Box Location
- Access panel size and location and weatherproofing
- Gas and electrical specs and location.
- Vent configuration.
- Finishing details.



NOTE: Provide the contractor with a printed copy of the “Building Checklist” and review requirements with them.

Installation

- Confirm the following items are properly located and built to specification:
 - Framing
 - Gas and electrical
 - Access panel (if applicable)
 - Air intake
- Clear a path free of any possible obstruction to carry in the fireplace.
- Uncrate the fireplace and set it in place.
- Make sure all stand-offs on the outside of the fireplace are fully extended.
- Secure the fireplace to the framing by attaching the nailing flanges to the framing. See “Securing the Fireplace” section.
- Remove all zip ties.
- Move the components to the access panel location. Be mindful of the routing for future service needs.
- Install the vent components. See “Vent Installation” section.
- Review the front wall requirements and finishing details with the contractor.
- Protect the fireplace and components from damage.

Securing the Fireplace

The fireplace has nailing flanges attached to the face of the fireplace (see figures below). The nailing flanges can be attached to the framing upon installation. It is crucial to the finishing that the fireplace is stable, level, and plumb. For added stability (though not required), re-use the shipping brackets to secure the legs of the fireplace to floor.

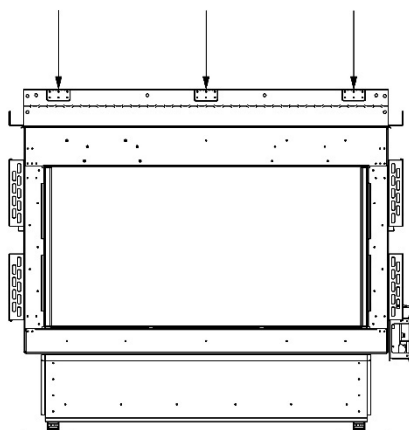

Nailing Flanges for Front Facing

Vent Installation

Venting must be installed according to the requirements detailed in the “Venting” section of this manual in conjunction with the vent system manufacturer’s installation instructions. Venting must be supported by the structural surrounding and not by the fireplace. Each elbow must be strapped to reduce movement or possible disconnection.

Startup

- Perform a visual inspection to confirm that all work was completed correctly and per specification.
- Confirm that gas and electrical are properly connected and live.
- Remove the safety barrier and glass and clean the inside of the fireplace.
- Install firelogs as specified in the “Firelog” section.
- Confirm the fireplace is operating properly.
- Check remote-control setup.
- Remove protective layer from glass.
- Clean glass.
- Reinstall the glass and safety barrier.
- Review operation of the fireplace and remote control with the owner.
 - Discuss location to store remote that is weatherproofed and within 26’ of the appliance.
- Set up return visit to clean glass after the Initial Burning Period (see “Post-Installation” section)

Post-Installation

Initial Burning Period

There is a 12-hour minimum burning period following installation of the fireplace. This 12-hour period must include a minimum of 4 consecutive hours of continuous burning. During this time, the owner or installer may notice:

- The glass developing a white or “cloudy” residue.
- An unusual smell

Both the residue and the smell are due to the paint on the fireplace metal heating and “burning off”. This is normal. The cloudiness and odor will disappear after the 12-hour period elapses and the installer returns to service the fireplace and complete startup.

Final Inspection Procedure

When the 12-hour burning period is complete, the installer should return and perform the final inspection, which includes:

- Cleaning the glass with a ceramic glass cleaner (otherwise the white residue will remain)
- Checking the interior media setup
- Checking for gas leaks
- Adjusting the restrictor (if necessary)
- Performing an overall check to make sure that everything is working properly.

When these activities are complete, initial startup is concluded, and the fireplace may be operated by the owner.

Final Checks and User Instruction

Before releasing the fireplace to the customer for use without installer supervision, the installer must ensure that the fireplace is burning correctly. In addition, the installer must review and explain the following to the owner:

- Safety warnings
- Fireplace operation
- Warranty requirements
- Maintenance requirements
- Glass is hot during and after operation.
- If any questions or concerns arise, the owner must contact the local Ortal dealer/installer for support.

Building Around the Fireplace

→Building Checklist

The following building checklist is a quick reference for a typical Wilderness Outdoor 44 series fireplace installation. This list is not exhaustive and does not supplement thorough review of the installation manual.

- ☑ **Fireplace Location:** Ensure the location allows for min. 16" clearance from viewing area to combustibles. Make sure a clear path is established to allow the fireplace to be safely transported to installation location.
- ☑ **Exhaust Vent:** Confirm vent size (5"x8"), vent clearance (1" on sides and bottom, 3" on top), vent configuration, and termination location.
- ☑ **Height from Floor:** Fireplace leg height is 14 1/8" (to the bottom of the lower drywall lip). Legs cannot be removed/altered.
- ☑ **Chase Floor:** Floor must be able to bear the weight of the fireplace. It must be constructed out of non-combustible materials.
- ☑ **Chase Construction:** No materials can be attached directly to the fireplace (exception: facing material that is 5/8" for flush finishing). **Weatherproofing** of the chase is essential when installing an outdoor fireplace.
- ☑ →**Framing:** Adhere to minimum framing dimensions (or greater). *When constructing the framing for the fireplace, please add up to +.25" variance to each side, and the top, of the fireplace frame. This added variance will allow added space to maneuver and adjust the fireplace when setting it in the chase.* Framing materials can only be **non-combustible**. For recessed fireplaces, do not exceed 12" max. front overhang depth limit. No material is permitted to extend past the metal lip surrounding the fireplace viewing area.
- ☑ **Gas Supply Line and Power Location:** Locate gas line with manual shut off according to local code. Power provided by a duplex outlet receptacle (120V, 15 amp, 60Hz) in same area as gas line. Ensure all local codes are followed, per the outdoor requirements.
- ☑ **Access Panel:** An access panel is necessary if the service box is located on the side of the unit to access gas and electrical components for servicing. If the service box is installed under the fireplace, servicing can be done through the fireplace, and an access panel is not necessary, but highly recommended.
- ☑ **Air Intake:** Required on all installations. Air intake must be 1" from the bottom of the chase and a minimum of 64 sq. inches (front, back, left or right side of the chase).
- ☑ **Finishes:** For finishes flush to the fireplace, no clearances are required. For finishes where the fireplace is recessed to the finish, maintain 1/8" from the finish to the front face of the fireplace. **All materials must be non-combustible.**

Framing

Framing Requirements

Fireplace chase may only be framed with non-combustible materials (typically metal studs).

The framing of the fireplace chase must be designed to carry the entire weight of the wall and finish material. The surrounding material must not transfer weight to the fireplace or be connected in any way to the fireplace. Consult with the project structural engineer and refer to your local building codes for proper wall support.

No material is permitted to extend past the $\frac{5}{8}$ " deep metal drywall lip surrounding the fireplace viewing area. This area must be unobstructed to allow the heat barrier and inside glass panel to be removed. A thickness of $\frac{5}{8}$ " will allow the finishing surface to be flush with the front of the unit.

Weather Proofing

- The fireplace must be located inside of a weatherproof enclosure.
- Flashing must be installed around the fireplace opening in accordance with local building codes to prevent moisture from entering the enclosure.
- A drip pan (not supplied with the unit) is recommended to be installed under the fireplace and be provided with a means of draining.
- Care must be taken to select materials and building practices which will protect the enclosure and fireplace from exposure to moisture.
- Water or moisture can accumulate through the screen, a deflector is designed into the front of the fireplace to help deflect this water in the chase.

Chase Floor/Leg Height

The fireplace must be installed on a flat, solid, continuous surface. Surface must be constructed from non-combustible materials.

The fireplace leg height is $14\frac{1}{8}$ ", measured to the bottom of the lower drywall lip. Legs cannot be removed, cut, or adjusted.

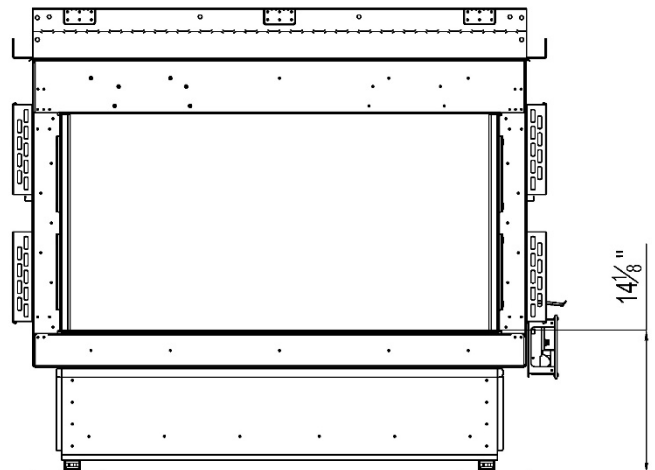

Fireplace Leg Height

Minimal Framing Dimensions

The following diagrams are for illustrative purposes only. There are multiple approved framing scenarios. A flush application is not the only permitted application. The fireplace may be recessed into the wall. Refer to diagrams and values below and in the following pages for details.

******When constructing the framing for the fireplace, please add up to +.25" variance to each side, and the top, of the fireplace frame. This added variance will allow added space to maneuver and adjust the fireplace when setting it in the chase.

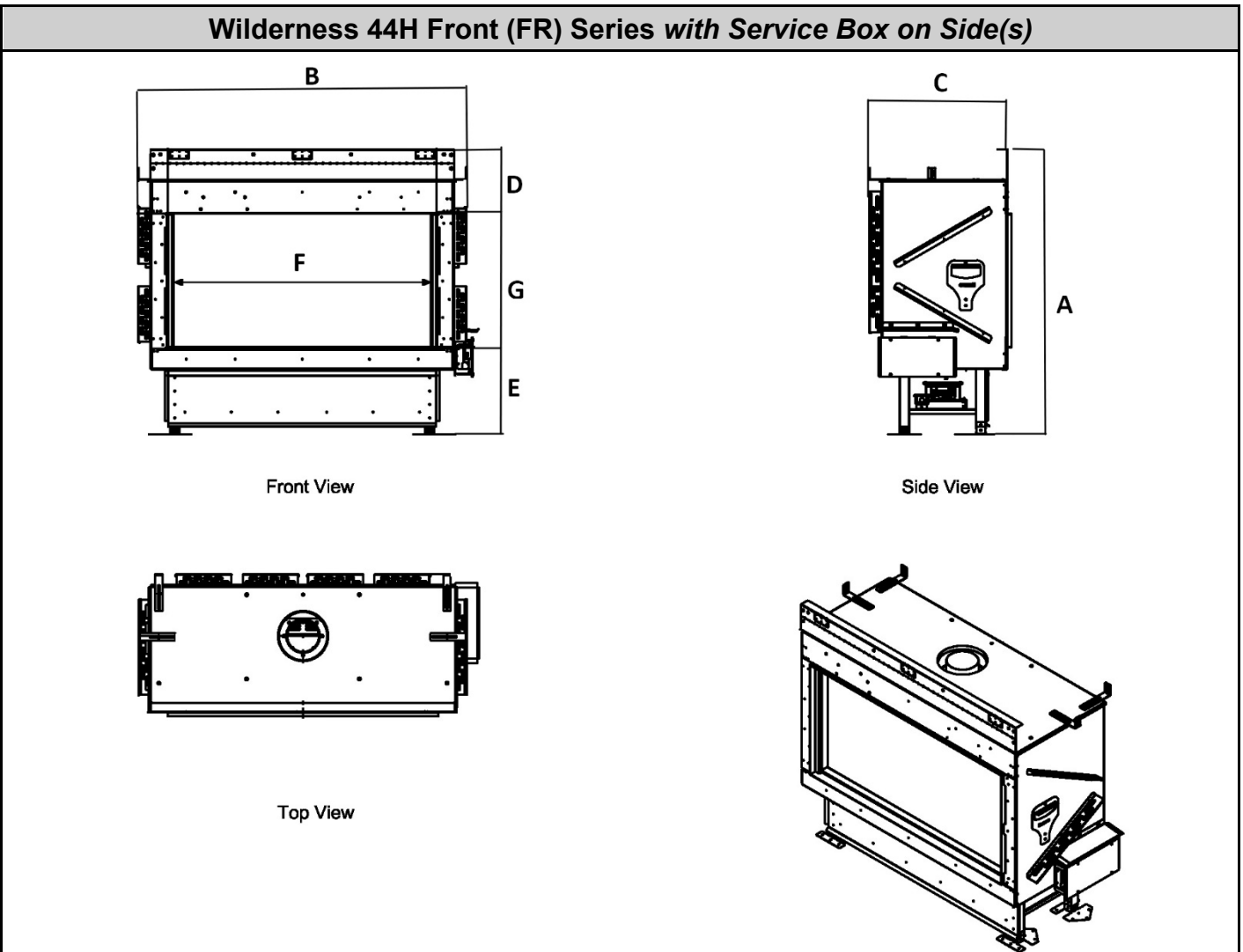

Fireplace	A: Height	B: Length	C: Depth	D: Stand-Off	E: Legs	F: Glass Length	G: Glass Height
44H FR	45 ⁷ / ₈ "	56 ⁷ / ₈ "	22 ¹ / ₄ "	10 ³ / ₈ "	14 ¹ / ₈ "	43 ⁵ / ₈ "	21 ⁵ / ₈ "

Framing	
Fireplace	44H FR
A: Height	45 ⁷ / ₈ "
B: Length	56 ⁷ / ₈ "
C: Depth	22 ¹ / ₄ "
D: Firestop	Refer to pipe manufacturer's firestop dimensions

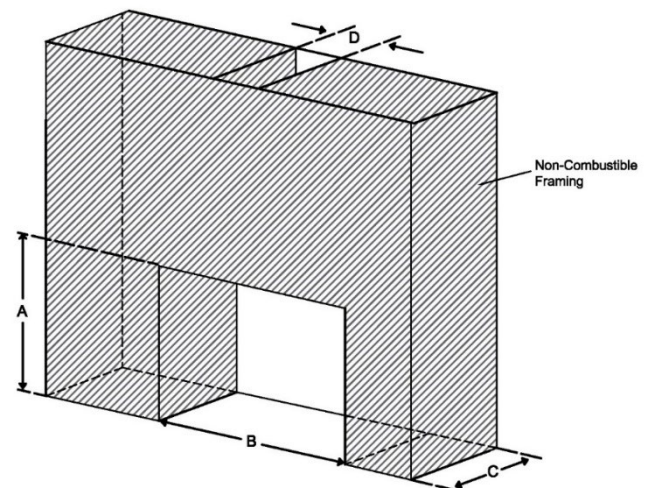

**Wilderness 44H Front (FR) Series
with Service Box underneath**

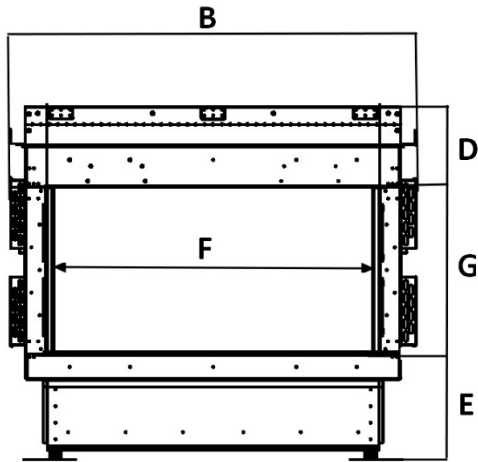

Front View

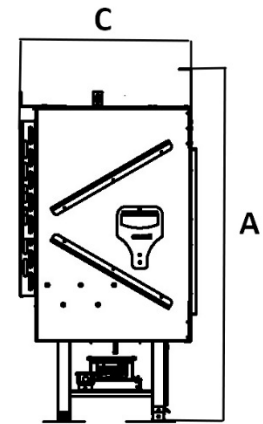

Side View

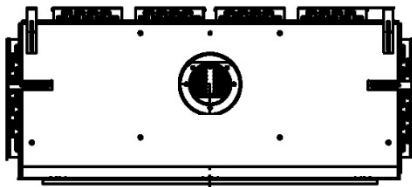

Top View

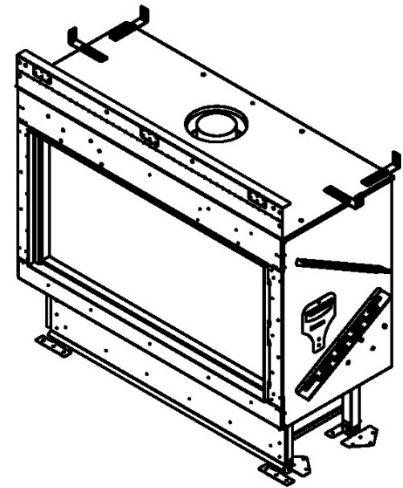

Fireplace	A: Height	B: Length	C: Depth	D: Stand-Off	E: Legs	F: Glass Length	G: Glass Height
44H FR	45 ⁷ / ₈ "	52 ⁷ / ₈ "	22 ¹ / ₄ "	10 ³ / ₈ "	14 ¹ / ₈ "	43 ⁵ / ₈ "	21 ⁵ / ₈ "

Framing	
Fireplace	44H FR
A: Height	45 ⁷ / ₈ "
B: Length	52 ⁷ / ₈ "
C: Depth	22 ¹ / ₄ "
D: Firestop	Refer to pipe manufacturer's firestop dimensions

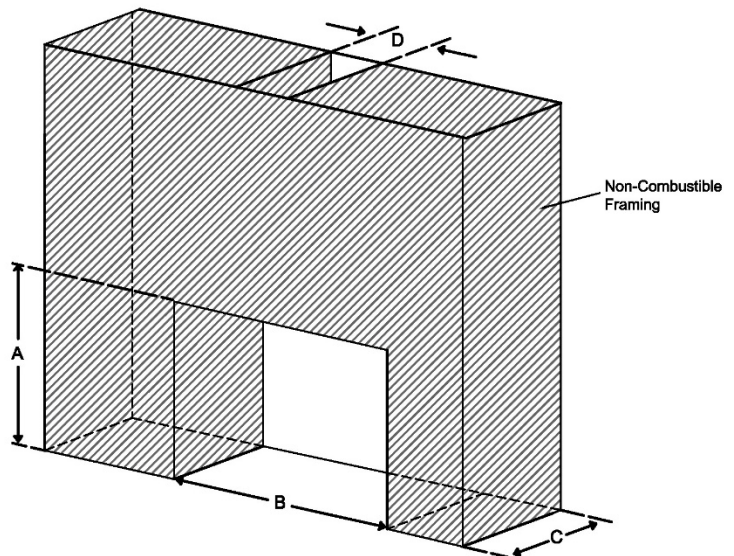

General Clearances

Viewing Area Clearance Zone

The viewing area clearance zone is an area that extends perpendicular from the fireplace viewing area. The depth of the viewing area clearance zone depends on the combustibility of the material in question. Distance is measured from the fireplace heat barrier.

Non-Combustible Materials	Must be minimum 12 inches from fireplace viewing area.
Combustible Materials	Must be minimum 16 inches from fireplace viewing area.

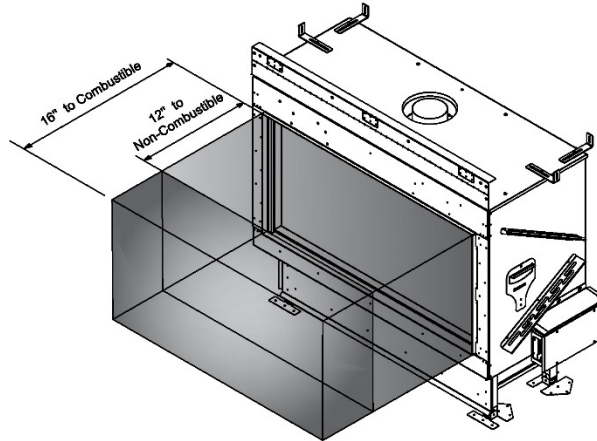



Materials (including flooring and non-combustible finish material) are permitted below and around the viewing area clearance zone.

! **IMPORTANT NOTE:** When placing material near the glass, take care to consider fireplace serviceability. It is strongly recommended that any items/materials placed in front of the front (long) glass be movable for easy access to the fireplace during servicing.

Clearance to a Side Wall

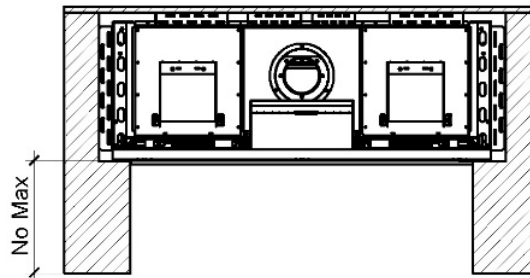
The fireplace viewing area is zero-clearance to a side wall. A side wall is defined as a wall that meets the viewing area at a 90° angle.



 = Building Material (must be non-combustible materials)

Air Intake Openings

An air intake opening must be incorporated into the framing and finish around the fireplace. The air intake opening is essential to maintain cool air flow throughout the chase. The opening must meet the minimum size requirement, as stated in the table below.

Fireplace Series	Air Intake Opening Size
Wilderness 44H	Minimum 64 sq. in. of free air space

The air intake opening should be finished in the form of a louvered ventilation grille, to prevent infiltration from the elements. The net free air space allowed in the louvered area must be equal to or greater than the minimum number of square inches required per fireplace.

The air intake is not required to be on the front of the chase. It can be placed on either the front, back, left or right side of the chase. The air intake must be 1" from the bottom of the chase to prevent any infiltration of standing water. A minimum of 64" square inches. Height cannot exceed the width of the air intake. If the components are placed on the right side of the fireplace, ensure that no outside elements will affect the service box.

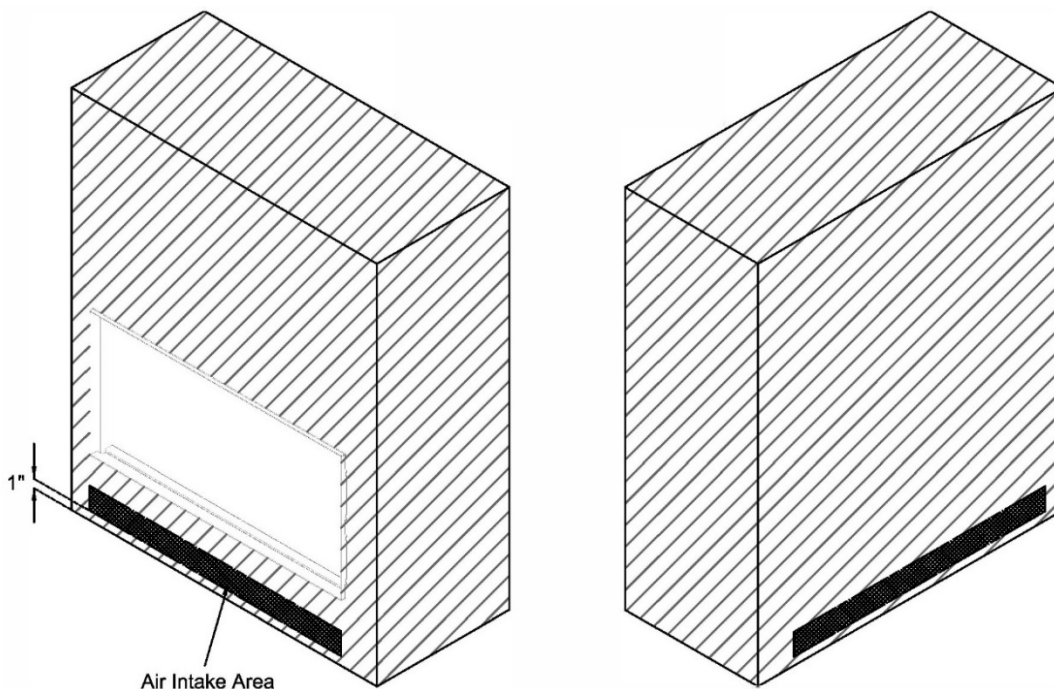

Air Intake on Front or Back of the Chase

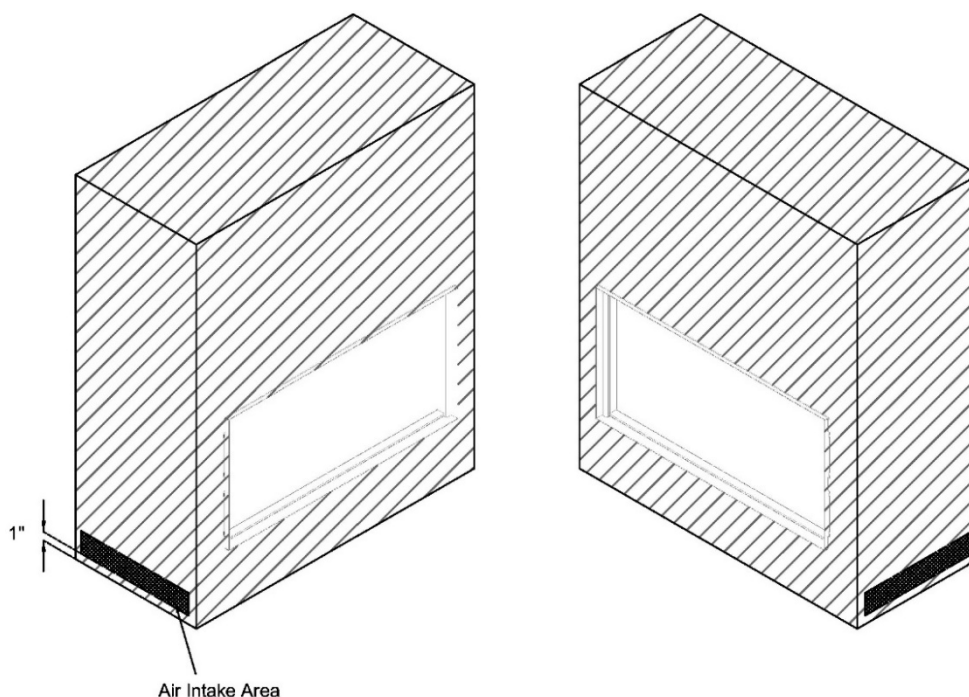

Air Intakes on Left or Right Sides of the Chase

Access Panel

Depending on the location chosen for the service box (side of unit or below) an access panel might be necessary. If you choose to put the service box below the unit (under the burner), you will be able to service the unit internally. If the service box is installed on the side of the fireplace, an access panel will be necessary for servicing. An access panel will also give you access to the control when installed below. Please refer to the "Servicing the Fireplace" section for details on how to access the service box.

Access Panel Size and Location Recommendations:

- Size: 8" height by 14" width is the **minimum**
- Location: Component box is located on the right side of the fireplace. Refer to image on the right.

The size and location of the access panel may vary, but in all cases, it must allow the technician to comfortably access and remove the component box to service the fireplace's gas and electrical components without compromising the weatherproofing integrity of the chase.

Prior to installation, fireplace dealers/installers should work with the owner, builder, project architects and/or interior designers to determine the best size and location of their access panel.

! NOTE: If local code requires an access panel, defer to local code requirements.

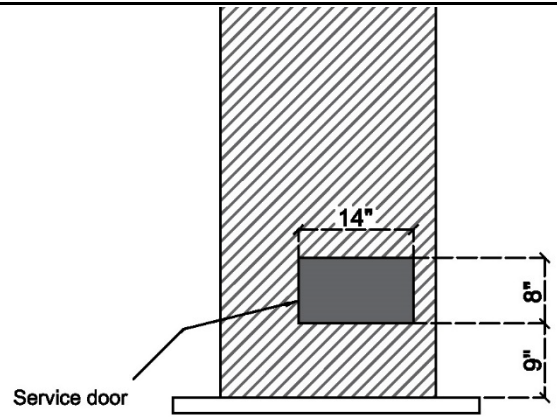

Finishing

The following diagrams show various finished applications. **Diagrams apply to only non-combustible finish material.**

! IMPORTANT NOTES:

- All recessed installations must comply with applicable maximum overhang limit and side wall clearances. See "Maximum Overhang/ Mantel Depth" and "Clearance to a Side Wall" sections for details.
- No material is permitted to extend past the metal lip surrounding the fireplace viewing area. This area must be unobstructed to allow the heat barrier and inside glass panel to be removable.
- All finishing materials must be non-combustible.

Flush Installation

Diagram applies to only non-combustible finish material.

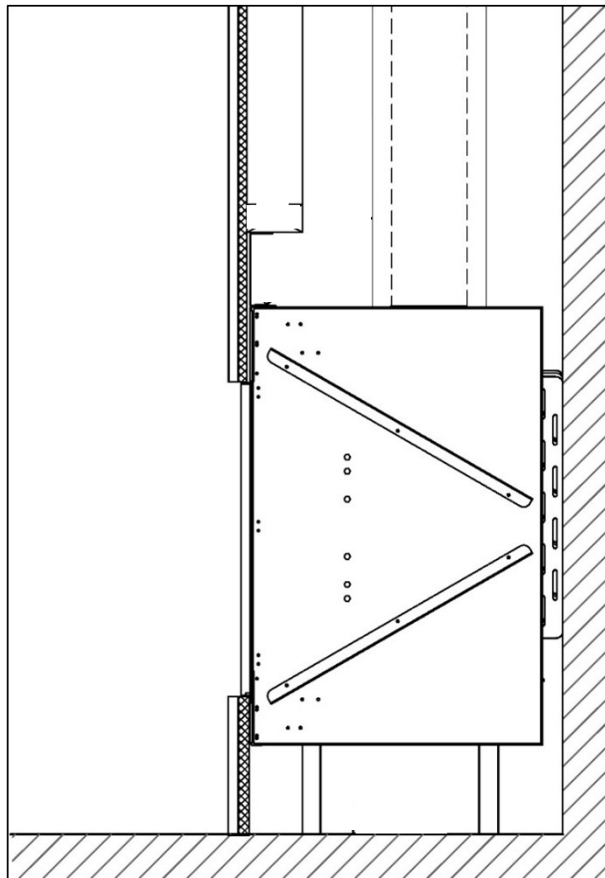

Recessed Installation

Diagram applies to only non-combustible finish material. The finish must maintain at least a 1/8" clearance to the fireplace to both the top and bottom recesses.

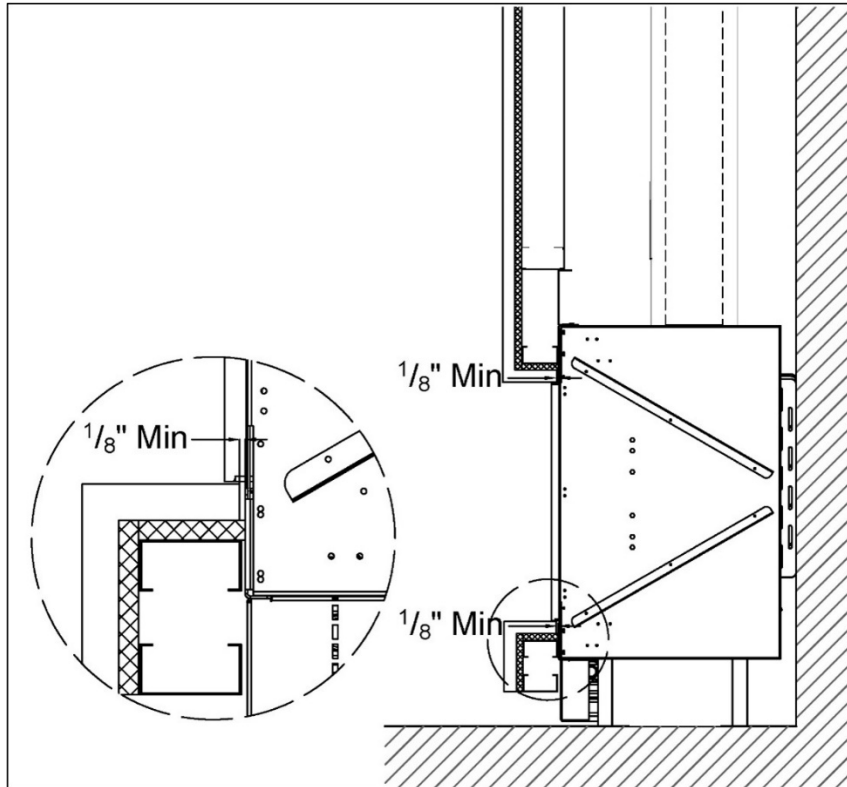

Maximum Overhang/ Mantel Depth

Overhang depth of a recessed fireplace must not exceed **12 inches** when located at the top finishing lip or top of the viewing area. Overhang depth is measured from the edge of the fireplace lip to the out-most part of the wall (including finish material). For a deeper, the overhang/mantel must be moved up the chase farther. **Side overhang has no limit.** Overhang/Mantel is required to be constructed out of all non-combustible materials.

Bottom recess (or "hearth extension") has no minimum or maximum depth requirement. If bottom recess depth exceeds 12 inches, ensure the structure is capable of supporting the weight of a fireplace technician for servicing. Framing and finishing materials must be non-combustible.

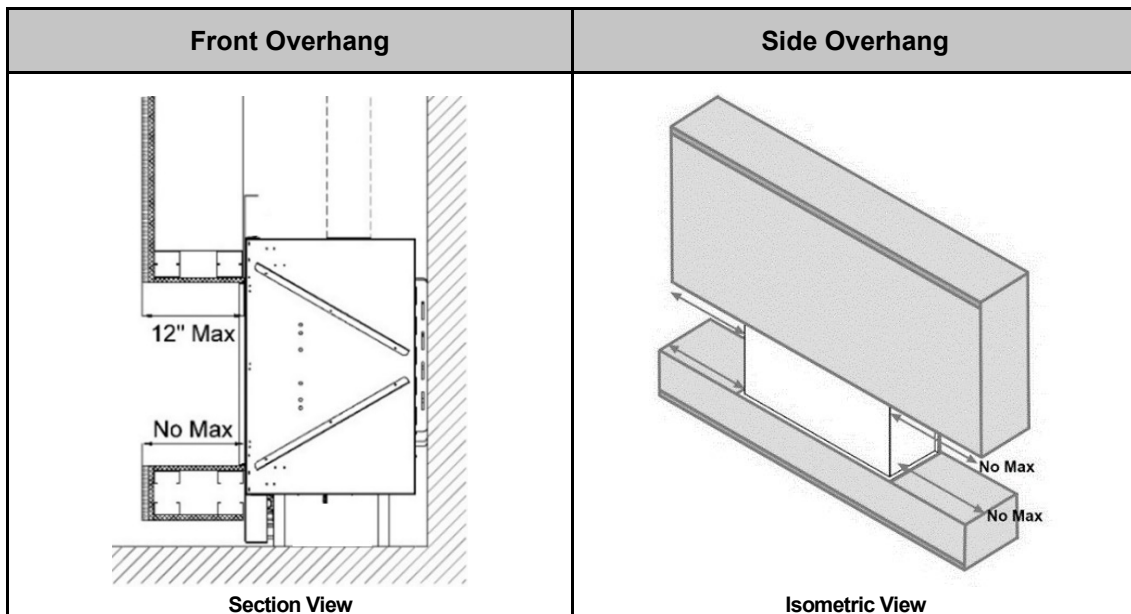



Venting

General Venting Requirements

The fireplace operates using a direct vent system and requires co-axial direct vent pipe. The fireplace must be properly connected to an approved vent system. Venting is not provided with the fireplace and must be sourced from one of the approved vent manufacturers mentioned in the table below. Proper installation, use, and maintenance of venting is determined by and can be acquired from the vent manufacturer.

Vent Requirements			
Fireplace Model	Direct Vent Type	Vent Size	Approved Vent Manufacturers
Wilderness 44H FR	Passive Vent (standard)	5x8 co-axial direct vent pipe (5" interior, 8" exterior)	Olympia: Ventis DuraVent: Direct Vent Pro ICC: EXCELDirect BDM: Pro-Form Direct Vent System Selkirk: Direct-Temp System

 **NOTE:** Depending on which approved vent manufacturer is used, it might be necessary to seal up the interaction at the top of the fireplace between the venting and outer wrap using flashing to create a tight seal.

 **TERMINATION CAP NOTE:** Low Profile Termination Cap and Sconce Termination Cap can negatively impact flame appearance and are not recommended for use with the fireplace.

 Power Vents are not allowed for use with Outdoor Fireplaces.

 **WARNING:** Do not combine vent components from different vent manufacturers. Please follow the manufacturer's instructions for vent system installation.

Vent Configurations

The following sections provide information for calculating vent configuration distances and elbows.

Please consider the following guidelines when determining vent configuration:

Elbows

- **Maximum Elbows:** Up to **four** 90° elbows can be used in the vent configuration. Two 45° elbows = one 90° elbow.
 - **45° Vertical Offset Exception:** Two 45° elbows in the vertical plane with a diagonal run in between is equal to **0 elbows**. They are not counted with other elbows in the vent configuration. This offset exception is applicable immediately on the top of the fireplace and anywhere else within the vent configuration.
The diagonal run between the two 45° elbows must be included when calculating vertical and horizontal distances.
 - **45° Horizontal Offset:** Two 45° elbows that begin and end in the horizontal plane, with a diagonal run in between, is equal to **one 90° elbow**. Additionally, **3 feet** must be reduced from the total allowable horizontal run.
The diagonal run between the two 45° elbows must be included when calculating vertical and horizontal distances
- **Flat 90° Elbows:** For every flat 90° elbow (a 90° elbow that stays in the horizontal plane), **6 feet** must be reduced from the total allowable horizontal run. Up to two flat elbows are allowed.
 - Example: If max allowable horizontal run is 24 feet and 1 flat elbow is added, max run is reduced to 18 feet.
- **Exceeding two 90° Elbows:** For more than two 90° elbows, the minimum total vertical rise is **6 feet**.

 **Exception:** If the 3rd 90° elbow in the vertical plane turns the vent direction from horizontal to vertical, the total allowable horizontal run does not require a 3-foot reduction.

Diagonal Runs

- **Calculating Diagonal Runs (D):** Diagonal (45°) vent runs have an equal combination of vertical and horizontal aspects. To include diagonal portions of your desired vent configuration when determining overall vent limitations, divide the diagonal distance in half. Add this value to the total vertical rise and total horizontal run distances in your vent configuration. Include these values when utilizing the Vent Configuration Tables below.
 - Example: 6 feet diagonal run = 3 feet vertical rise & 3 feet horizontal run

Other

- **V Minimum:** This is the minimum amount of vertical rise required before the first *completely* horizontal (not diagonal) run.
- Any vent configuration that does not meet these parameters requires Ortal's review and approval.

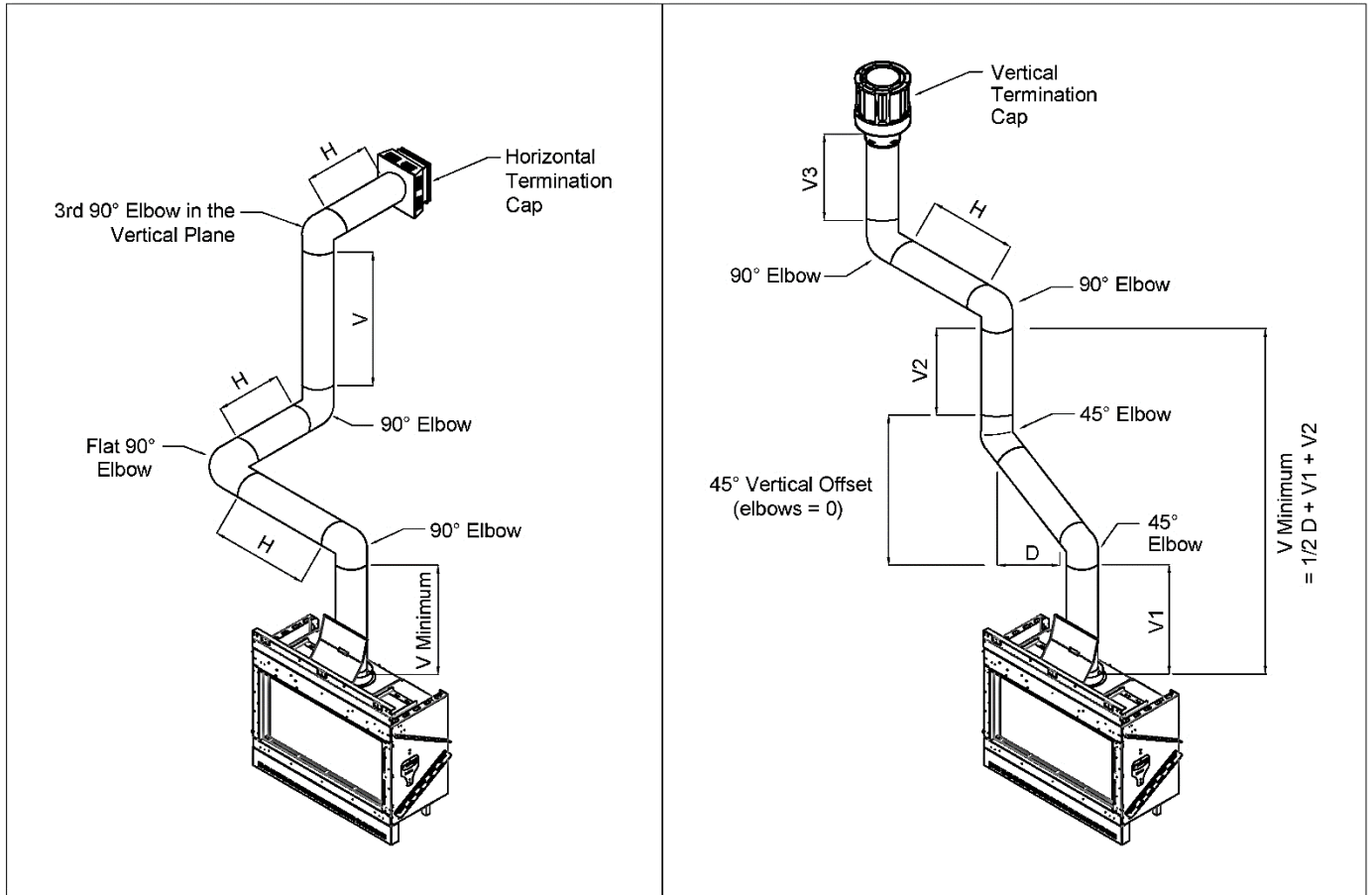

! TERMINATION CAP NOTE: Low Profile Termination Cap and Sconce Termination Cap can negatively impact flame appearance and are not recommended for use with the fireplace.

Allowable Maximum Horizontal Runs

Wilderness 44 Series	
V minimum = 3 feet	
Vertical (V)	Max Horizontal (H)
3 ft	7 ft
6 ft	12 ft
9 ft	18 ft
12 ft	21 ft
15 ft	21 ft
18 ft	18 ft
21 ft	18 ft
24 ft	18 ft
27 ft	12 ft
30 ft	12 ft
33 ft	12 ft
36 ft	6 ft
39 ft	0 ft
42 ft	0 ft
45 ft	0 ft

! CHART NOTE: Do not include the space elbows take up when calculating your vertical and horizontal distances.

Vent Restrictor Sizing Guidelines

The restrictor sizing tables in this section determine the recommended restrictor for your vent configuration. These tables show Ortal's recommendations only. The Environment, gas type and other factors may affect the best restrictor choice.

How to use the "Recommended Restrictor" tables:

1. Find the total vertical rise in your vent configuration along the y-axis.
2. Find the horizontal run in your vent configuration along the x-axis.
3. Follow the desired rise and run values within the table until they meet. This value is the recommended restrictor size (in inches) for your vent configuration.

Legend:

X: Vent configuration is not allowed. Power vent required.

0: No restrictor required.

Numbers other than 0: Represents the recommended restrictor (by width).

Restrictor Sizes:

- 20mm (0.79")
- 30mm (1.18")
- 40mm (1.57")
- 50mm (1.97")
- 70mm (2.75")
- 85mm (3.35")

Wilderness 44H Series Fireplaces V Minimum = 3 Feet													
Total Vertical Vent Rise	45'	2.75"	X	X	X	X	X	X	X	X	X	X	
	42'	2.75"	X	X	X	X	X	X	X	X	X	X	
	39'	2.75"	X	X	X	X	X	X	X	X	X	X	
	36'	2.75"	0	0	X	X	X	X	X	X	X	X	
	33'	2.75"	1.97"	1.97"	1.97"	0	X	X	X	X	X	X	
	30'	2.75"	1.97"	1.97"	1.97"	0	X	X	X	X	X	X	
	27'	2.75"	1.97"	1.97"	1.97"	0	X	X	X	X	X	X	
	24'	2.75"	2.75"	2.75"	1.97"	1.57"	0	0	X	X	X	X	
	21'	2.75"	2.75"	1.97"	1.97"	1.57"	1.18"	0	X	X	X	X	
	18'	1.97"	1.97"	1.97"	1.57"	1.57"	1.18"	0	X	X	X	X	
	15'	1.97"	1.97"	1.97"	1.57"	1.57"	1.18"	0	0	X	X	X	
	12'	1.97"	1.97"	1.57"	1.57"	1.18"	1.18"	0	0	X	X	X	
	9'	1.57"	1.57"	1.18"	1.18"	0	0	0	X	X	X	X	
6'	1.18"	0	0	0	0	X	X	X	X	X	X		
3'	0	0	0	X	X	X	X	X	X	X	X		
0'	X	X	X	X	X	X	X	X	X	X	X		
		0'	3'	6'	9'	12'	15'	18'	21'	24'	27'	30'	33'
		Horizontal Vent Run											

Clearances

The following clearances apply to the vent system regardless of vent manufacturer.

Vent Clearances	
Sides: 1"	Applies to entire circumference when venting is oriented vertically. Clearance is to any material.
*Top: 3"	Applies to venting oriented horizontally or at an angle. Clearance is to any material.
Bottom: 1"	

***Exception:** Wall thimble top clearance to any material is 1".

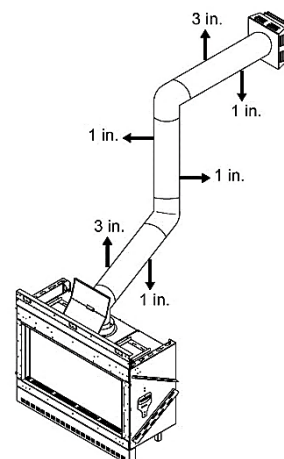

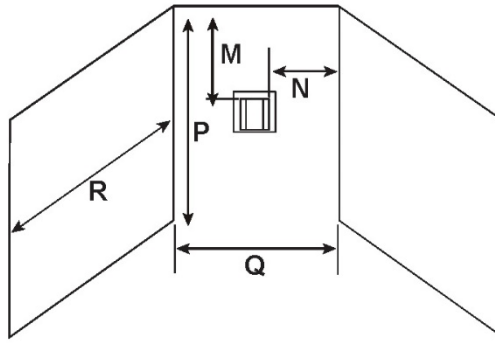

Covered Alcove: spaces open only on one side and with an overhang

Horizontal Termination Clearances Continued: Covered Alcove Application				
Location	Country	Minimum Clearance	Description	
COVERED ALCOVE APPLICATION	M	US & Canada	16 inches	Clearance under non-vinyl veranda, porch, deck, balcony, or overhang. NOTE: Termination in a covered alcove space is permitted with the dimensions specified. 1. There must be 3 feet minimum between termination caps. 2. All mechanical air intakes within 10 feet of a termination cap must be a minimum of 3 feet below the termination cap. 3. All gravity air intakes within 3 feet of a termination cap must be a minimum of 1 foot below the termination cap.
	N	US & Canada	6 inches	Non-vinyl sidewalls.
			12 inches	Vinyl sidewalls.
	P	US & Canada	8 feet	Alcove height.
	Q	US & Canada	See table below.	Alcove width (dependent on number of caps in the space).
R	US & Canada	See table below.	Alcove depth (dependent on number of caps in the space).	

# Vent Caps	Q_{MINIMUM}	R_{MAXIMUM}
1 vent cap	3 feet	$2 \times Q_{\text{ACTUAL}}$
2 vent caps	6 feet	$1 \times Q_{\text{ACTUAL}}$
3 vent caps	9 feet	$\frac{2}{3} \times Q_{\text{ACTUAL}}$
4 vent caps	12 feet	$\frac{1}{2} \times Q_{\text{ACTUAL}}$
$Q_{\text{MIN}} = \# \text{ vent caps} \times 3$		$R_{\text{MAX}} = (\frac{2}{\# \text{ vent caps}}) \times Q_{\text{ACTUAL}}$

! HORIZONTAL TERMINATION CAP CLEARANCES - NOTES:

- If exterior walls are finished with vinyl siding, it is *required* that a vinyl protector kit be installed.
- Vent system termination is not permitted in screened porches.
- Vent system termination is permitted in porch areas with two or more sides open. You must follow all side walls, overhang and ground clearances as stated.
- Termination caps may be hot. Consider their proximity to doors or other traffic areas.

Vertical Termination Clearance Diagram

Minimum Height From Roof To Lowest Discharge Opening

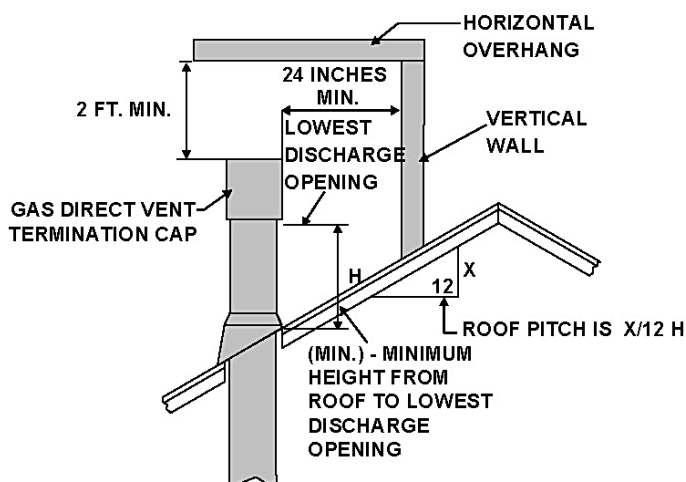

Roof Pitch	H (Min.) Ft.
Flat to 6/12.....	1.0*
Over 6/12 to 7/12.....	1.25*
Over 7/12 to 8/12.....	1.5*
Over 8/12 to 9/12.....	2.0*
Over 9/12 to 10/12.....	2.5*
Over 10/12 to 11/12.....	3.25
Over 11/12 to 12/12.....	4.0
Over 12/12 to 14/12.....	5.0
Over 14/12 to 16/12.....	6.0
Over 16/12 to 18/12.....	7.0
Over 18/12 to 20/12.....	7.5
Over 20/12 to 21/12.....	8.0

*H min. may vary depending on regional snowfall. Refer to local codes.

Staggered Termination Caps

A	B
6 in. (minimum) up to 24 in.	18 in. minimum
24 in. and over	0 in. minimum

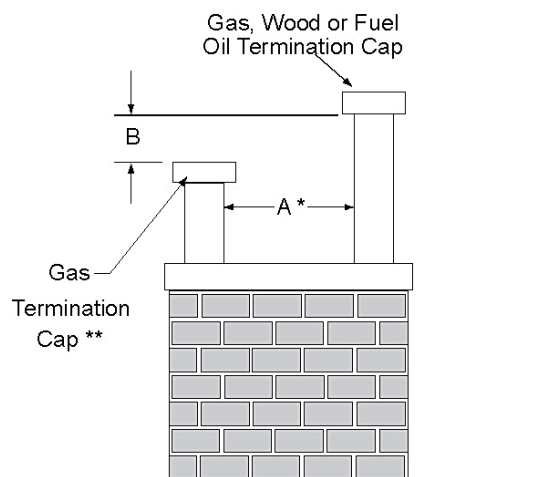

* If using decorative cap cover(s), this distance may need to be increased. Refer to the installation instructions supplied with the decorative cap cover.

** In a staggered installation with both gas and wood or fuel oil terminations, the wood or fuel oil termination cap must be higher than the gas termination cap.

Notes:

1. Maintain a minimum of 2 feet clearance between edge of vertical termination and perpendicular wall.
2. If terminating near window, keep minimum of 2 feet clearance between window and vent termination.
3. All mechanical air intakes (such as an Enervex power vent) within 10 feet of a termination cap must be a minimum of 3 feet below the termination cap.
4. All gravity air intakes within 3 feet of a termination cap must be a minimum of 1 foot below the termination cap.

NOTE: This chart does not apply to a chimney shroud application.

Vent Installation

Venting must be installed to meet the requirements as detailed in the following sections in conjunction with the vent system manufacturer's installation instructions. Venting must be supported by the structural surrounding and not by the fireplace. Each offset (elbow) must be strapped to reduce movement or possible disconnection.

The first section of venting must be secured to the fireplace starter collar with a minimum of 3 sheet metal screws no longer than 1/2". DO NOT use silicone to seal the sections. If sealing is required by the vent manufacturer or local code, use Mil-Pac sealant.

 **WARNING: Do not combine vent components from different vent manufacturers. Please follow the manufacturer's instructions for vent system installation.**

Vent Maintenance

Regular inspection of the vent system by a qualified service technician is recommended annually. The following maintenance routing is recommended:

- Inspect for excessive condensation, e.g., water droplets forming in the inner lining, and subsequently dripping from the joints. This can cause corrosion in the system.
- Check for corrosion in areas exposed to the elements. Components with rust spots or holes must be immediately replaced.
- Ensure that there is no foreign material in the vents. Survey by removing the cap and shining a light down the vent.
- If possible, check all vent joints to make sure nothing has been disturbed or loosened.

Gas

The fireplaces are approved for use with natural gas (NG) or propane (LP) only. No other fuel types are permitted.

Gas Pressures

Fireplace Series	Firelog Burner	Gas Type	Inlet Pressure		Manifold Pressure	Heat Input (BTU/hr)		Orifice Size*
			Min	Max		Min	Max	
Wilderness 44H FR	Driftwood, Valley Oak or Birch Firelogs (BL70)	Natural Gas	7.0	11.0	5.0	15,696	33,500	320-160-320 380
		Propane	11.0	13.0	4.7	21,400	29,000	90-60-90 180

*Wilderness Orifice Size, Top Row (left to right): Left log, center log, right log. Bottom Row: Bottom of burner.

 **NOTE: It can take up to 20 minutes for the flames to turn yellow.**

Routing the Gas Line

Correctly size and route the gas supply line from the supply regulator to the area where the access panel is located (or to the burner area if no access panel is available), as per the requirements outlined in the latest edition of the National Fuel Gas Code, NFPA 54 (USA) or CSA-B149.1 (Canada). Gas valve inlet accepts a 3/8" NPT fitting.

The gas and electrical components are attached to the pilot on a flexible gas line and can be kept directly under the fireplace or to the side of the appliance. Location should have been predetermined before installation, as framing dimension will vary depending on location of this service box.

This appliance and its individual shut off valve must be disconnected from gas supply piping system during any pressure testing of that system at test pressures in excess of 1/2 psig (3.5 kPa).

This appliance must be isolated from the gas supply piping system by closing its individual manual shut off valve during any pressure testing of the gas supply piping system at test pressures equal to or less than 1/2 psig (3.5 kPa). A gas shut-off valve and a 12" gas flex connector are provided with every fireplace. The location of the gas shut-off valve is dependent on local codes and requirements. Check with your authority having jurisdiction for more information.

 **WARNING: The main gas valve must be installed to allow complete disconnection of the fireplace from the gas supply piping system for servicing purposes.**

Gas Conversion

For Wilderness 44 series fireplace gas conversion (NG to LP or LP to NG) to be performed in the field, Firelogs for the desired gas type must have been ordered and on site before gas conversion can occur. Firelog installation and gas conversion must be performed only by technicians who have specific authorization by Ortal to change these components. The Driftwood Firelog Kit must be supplied by Ortal. Using parts from other manufacturers or having an unauthorized party performing the conversion will void your fireplace's warranty. Conversion instructions are supplied with the kit.

Driftwood Firelog Conversion Set for Natural Gas: **SKU: GCLNDW700-US**
Driftwood Firelog Conversion Set for Propane: **SKU: GCNLDW700-US**

Valley Oak Firelog Conversion Set for Natural Gas: **SKU: GCLNVLYOK3LO**
Valley Oak Firelog Conversion Set for Propane: **SKU: GCNLVLYOK3LO**

Birch Firelog Conversion Set for Natural Gas: **SKU: GCLNBIRCHB703LO**
Birch Firelog Conversion Set for Propane: **SKU: GCNLBIRCHB703LO**

! NOTES:

- Log sets for NG and LP have different SKUs. Please consult the price list to ensure you have the correct SKU.
- LP logs do not contain nickel strands inside the logs and consist of long ports/channels for gas flow. NG logs do contain nickel strands and consist of round circular ports for gas flow.

High Altitude Requirements

For elevations above 2,000 feet, the fireplace shall be re-rated 4% for each 1,000 feet above sea level.

For Canada: Input ratings are certified without a reduction of input rate for elevations up to 4500 feet above sea level. Please consult provincial and/ or local authorities having jurisdiction for installations at elevations above 4500 feet.

Electrical

This appliance must be electrically wired and grounded in accordance with local codes or, in the absence of local codes, with National Electric Code ANSI/NFPA 710-latest edition or Canadian Electric Code CSA C22.1.

! WARNING: Disconnect the power supply before servicing any electrical components.

Electrical Requirements

A duplex receptacle with one outlet (not included) must be installed in the location where the gas and electrical components will be placed, which must be to the side or back of the fireplace depending on the location of the service box. Electrical work should be performed by a qualified licensed electrician, per local code for an outdoor product. GCFI outlet might be necessary.

Outlet Type	Power Requirements
1 Duplex Receptacle (1 outlet)	120V, 15 amp, 60Hz

The outlet should be a **NEMA (National Electrical Manufacturers Association) Class 3** rated receptacle at minimum or weatherproof rated. All outdoor rated boxes will carry a NEMA Class 3 rating.

! NOTE: Any device that functions using the same radio frequency as the handset will be affected when remote-controlled handset is in use.

Pairing the Remote and Receiver

To set up the remote-control device to operate the fireplace, follow the following guidelines to pair the remote and receiver unit on the same radio frequency.

- Press and hold the receiver's reset button until you hear two beeps. The first beep is short, and the second beep is long. After the second beep, release the reset button.



- Within the subsequent 20 seconds, press the following button depending on the mode of operation:
 - 10-Button Handset:** Press the  button. "CONN" and a running number from 1 to 8 will appear on the handset display confirming that the synchronization and data exchange are in process.
- You will hear two short beeps confirming the connection.

! NOTES:

- If you hear one long beep, this indicates the connection has failed or the wiring is incorrect.
- The connection between remote and receiver only needs to be made once and is not required after changing the batteries in the remote.

Wiring Diagram

Wiring Diagram: Screen Fireplace with Interior Lighting

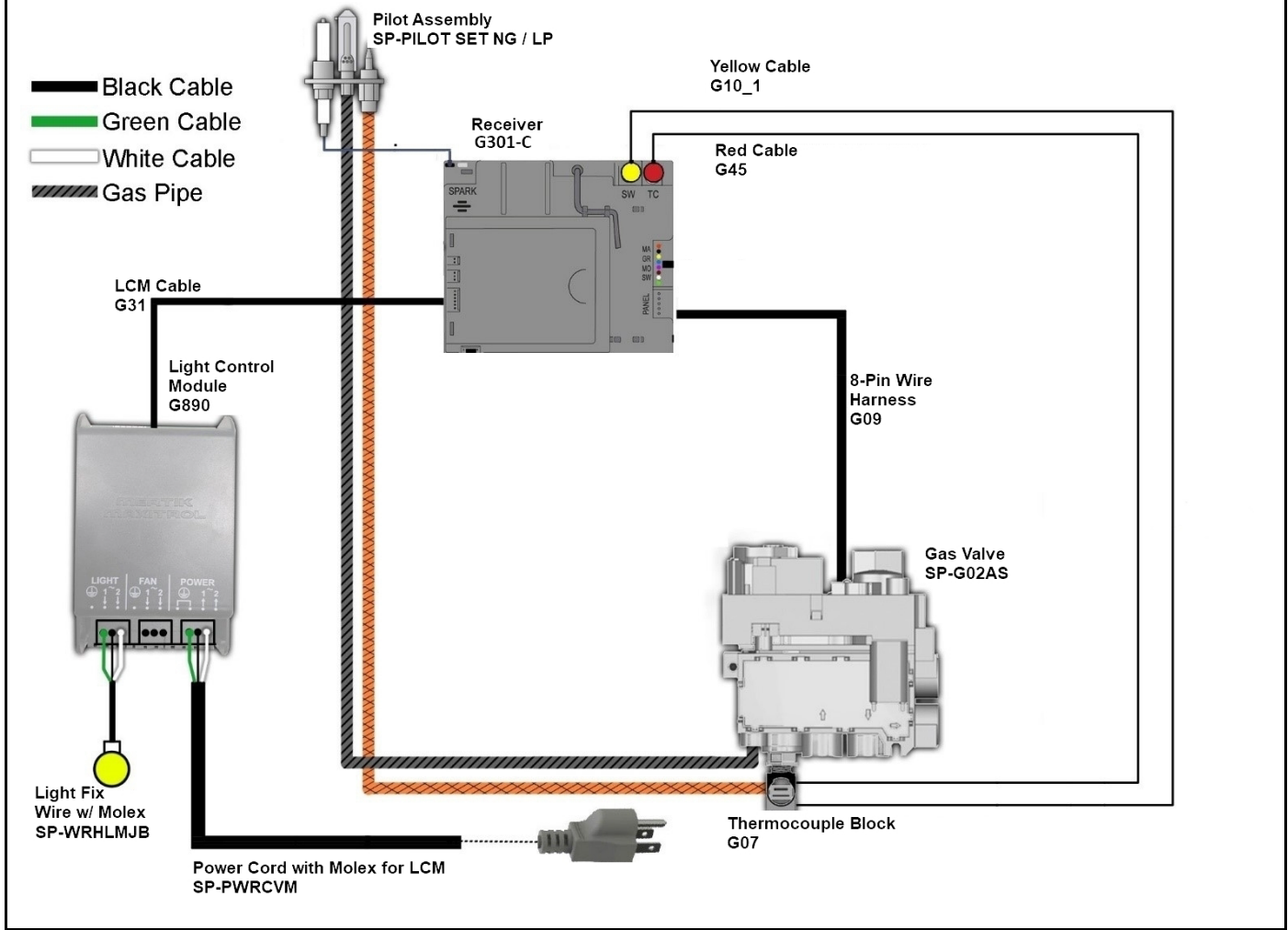

Replacement Parts

Parts are available through authorized Ortal Dealers.

Description	Part Number
Receiver	G301-C
Remote	G300
Pilot Assembly	NG: SP-PILOT SET NG LP: SP-PILOT SET LP
Yellow Cable	G10_1
Red Cable	G45
8-Pin Wire Harness	G09
Gas Valve	SP-G02AS
Thermocouple Block	G07
Light Control Module	G890
Cable for LCM	G31
Light Fix Wire with Molex	SP-WRHLMJ
Power Cord Fix with Molex	SP-PWRCVM
Wall Switch	G83 (optional)

Firelog Installation Warnings

1. **Firelogs are fragile.** Handle them gently to prevent damage to their paint or to the fireplace.
2. **Arrange firelogs as shown in the section below.** Do not arrange them in any other way. If firelogs are not installed per installation instructions, flame impingement and improper combustion may occur and result in soot and/or excessive production of carbon monoxide (CO). Carbon monoxide is a toxic, colorless, and odorless gas.
3. **Do not install the firelog media until** fireplace installation is complete, the gas line is connected and tested for leaks, and initial burner operation has been inspected and approved.
4. **Keep 1 inch around the pilot (behind pilot hood) completely clear of any media or debris.** Contact between the nickel strands and the spark plug cable may lead to failure operating the fireplace.
5. **Do not cover the main burner holes** (marked in the image below) unless otherwise stated in this manual. Blocking the holes can cause a gas release that could cause an explosion in the fireplace.

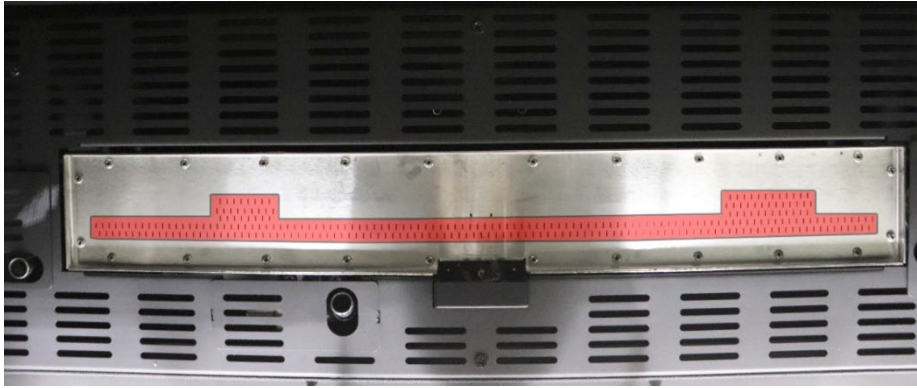

6. **Placing the log onto the log base/tube:**

Step 1: Grasp the log at both ends as shown in the picture

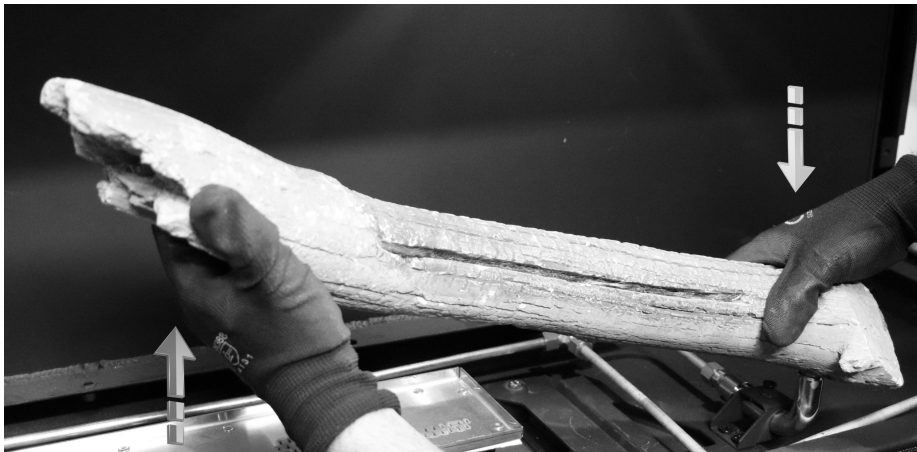

Step 2: Insert the tube coming out of the log into its base while making gentle rotational movements back and forth around its axis for easy insertion/removal. See figure below.

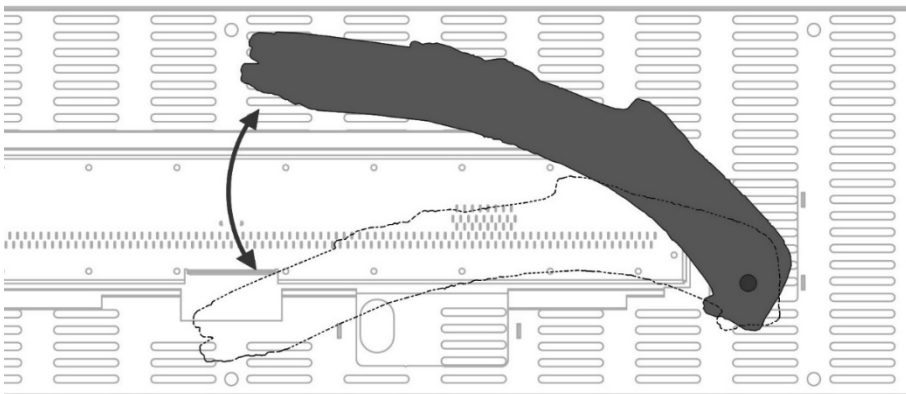

Top View

WARNING: Using force when installing the log onto its base/gas tube may result in breakage or damage to the log that will require its replacement.

Driftwood Firelog Set

Wilderness Driftwood Firelogs are designed for use in the Wilderness series fireplaces only. No other interior design media options are permitted for Wilderness series fireplaces.

DRIFTWOOD FIRELOG SETS ARE DIFFERENT FOR NG AND LP:

- Firelog sets for NG and LP have different SKUs. Please ensure you have correct SKU for desired gas type prior to ordering.
- LP logs do not contain nickel strands inside the logs. NG logs do contain nickel strands.

! NOTE: It can take up to 20 minutes for the flames to turn yellow.

! WARNING: Failure to position these logs in accordance with the instructions and diagrams below or failure to use the parts specifically approved with this appliance may result in property damage or personal injury.

The following items are included with the Driftwood Firelog set for the Wilderness 44 series fireplaces.



Items supplied with Driftwood Log set

Driftwood Firelog Setup

Log placement of the Driftwood Firelog Set is crucial for optimal fireplace operation and safety purposes. Logs must be arranged as detailed in the following pages. No other arrangement is permitted. Alternative log arrangement will affect fireplace safety, operation, and performance. Setup can take up to 1 hour to complete. Handle logs gently to avoid paint damage. Log placement is the same for NG and LP.

STEP 1: Nickle Strands

1. Use your fingers to separate the nickel strands (supplied 2x20" long) as shown in the image below. It is recommended to cut the nickel strips into 10 equal strips to make it easier to separate them.



Left: Nickel strands as supplied | Right: Nickel strands ready to use

2. Place nickel strands on top of the burner holes. Keep nickel strands a minimum of 1 inch from the pilot.



⚠ WARNING: For safety and optimal fireplace function, keep 1 inch around the pilot (behind pilot hood) completely clear of any media or debris.

Arrange firelogs as shown in Steps 2-9.

STEP 2

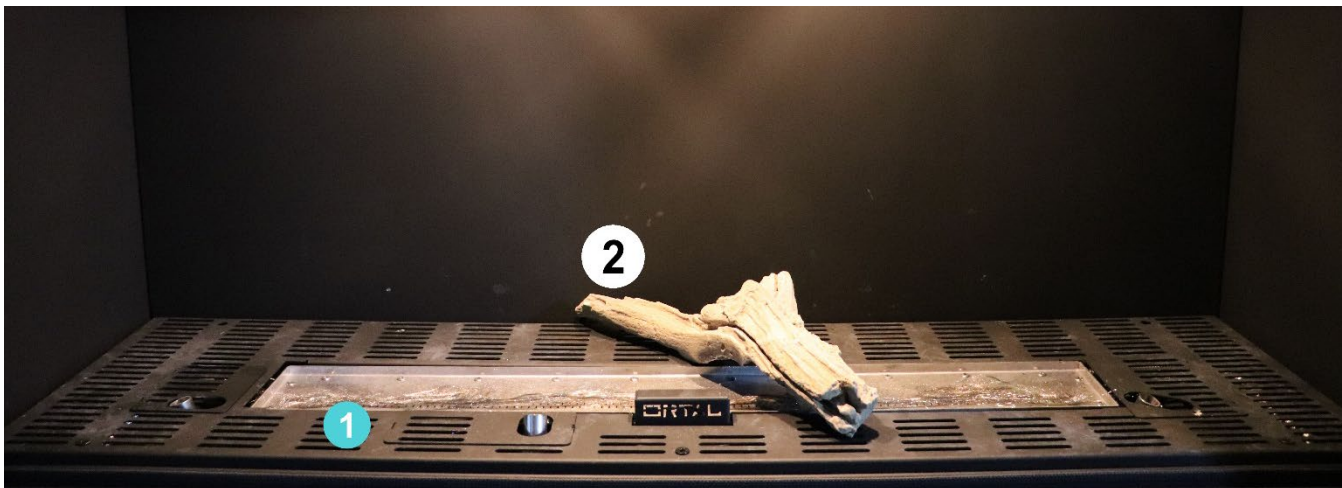

STEP 3



The base of log #3 can be adjusted to fit the position shown in pictures above (see "Log Base Position Adjustment" section for details).

STEP 4



STEP 5



STEP 6



The base of log #6 can be adjusted to fit the position shown in pictures above (see “Log Base Position Adjustment” section for details).

STEP 7



The base of log #7 can be adjusted to fit the position shown in pictures above (see “Log Base Position Adjustment” section for details).

STEP 8



STEP 9

Add charcoal pieces to the bottom of the firebox. Do not cover any burner holes. Maintain minimum 1-inch clearance around the pilot behind pilot hood.



⚠ WARNING: For safety and optimal fireplace function, keep 1 inch around the pilot (behind pilot hood) completely clear of any media or debris.

⚠ WARNING: To prevent log breakage, follow these log instructions carefully. The gas logs ***MUST*** be supported by additional logs as directed as they were not designed to support their own weight solely from the gas supply tube.

Valley Oak Firelog Set

Wilderness Valley Oak Firelogs are designed for use in the Wilderness series fireplaces only. No other interior design media options are permitted for Wilderness series fireplaces.

VALLEY OAK FIRELOG SETS ARE DIFFERENT FOR NG AND LP:

- Firelog sets for NG and LP have different SKUs. Please ensure you have correct SKU for desired gas type prior to ordering.
- LP logs do not contain nickel strands inside the logs. NG logs do contain nickel strands.

! NOTE: It can take up to 20 minutes for the flames to turn yellow.

! WARNING: Failure to position these logs in accordance with the instructions and diagrams below or failure to use the parts specifically approved with this appliance may result in property damage or personal injury.

The following items are included with the Valley Oak Firelog set for the Wilderness 44 series fireplaces.

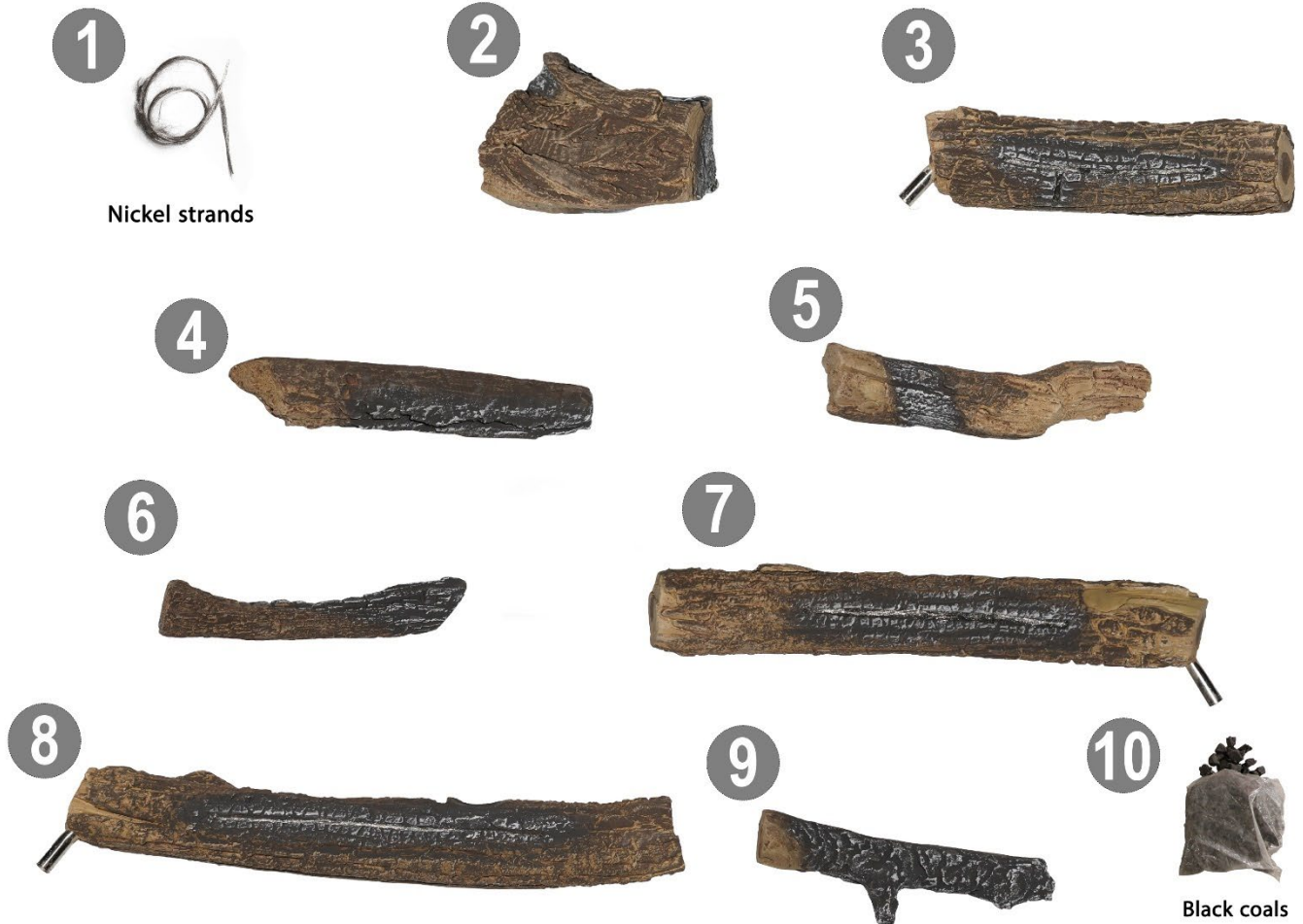

Valley Oak Firelog Setup

Log placement of the Valley Oak Firelog Set is crucial for optimal fireplace operation and safety purposes. Logs must be arranged as detailed in the following pages. No other arrangement is permitted. Alternative log arrangement will affect fireplace safety, operation, and performance. Setup can take up to 1 hour to complete. Handle logs gently to avoid paint damage.

STEP 1: Nickle Strands

1. Use your fingers to separate the nickel strands (supplied 2x20" long) as shown in the image below. It is recommended to cut the nickel strips into 10 equal strips to make it easier to separate them.



Left: Nickel strands as supplied | Right: Nickel strands ready to use

2. Place nickel strands on top of the burner holes. Keep nickel strands a minimum of 1 inch from the pilot.



⚠ WARNING: For safety and optimal fireplace function, keep 1 inch around the pilot (behind pilot hood) completely clear of any media or debris.

Arrange firelogs as shown in Steps 2-9.

STEP 2

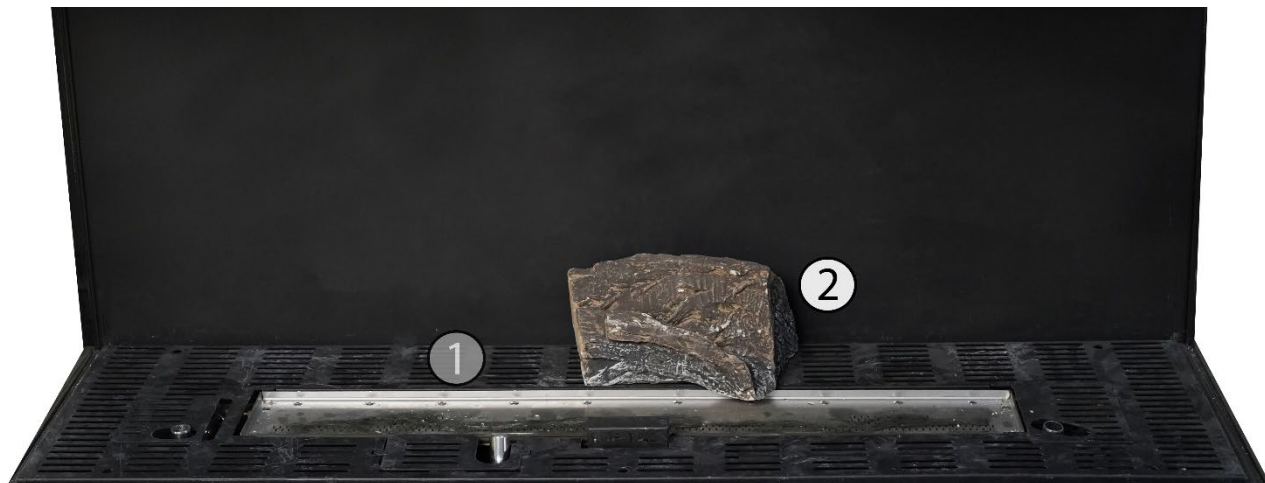

STEP 3

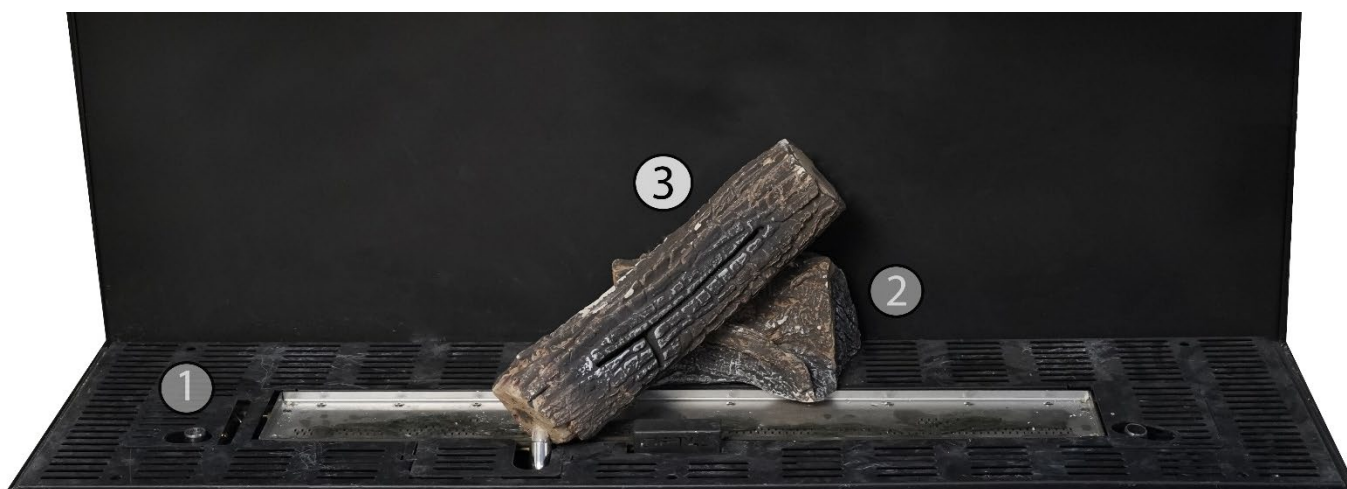

The base of log #3 can be adjusted to fit the position shown in pictures above (see "Log Base Position Adjustment" section for details).

STEP 4



STEP 5



STEP 6



STEP 7



The base of log #7 can be adjusted to fit the position shown in pictures above (see “Log Base Position Adjustment” section for details).

STEP 8



The base of log #8 can be adjusted to fit the position shown in pictures above (see “Log Base Position Adjustment” section for details).

STEP 9



STEP 10

Add charcoal pieces to the bottom of the firebox. Do not cover any burner holes. Maintain minimum 1-inch clearance around the pilot behind pilot hood.



⚠ WARNING: For safety and optimal fireplace function, keep 1 inch around the pilot (behind pilot hood) completely clear of any media or debris.

→ Birch Log Firelog Set

Wilderness Birch Log Firelogs are designed for use in the Wilderness series fireplaces only. No other interior design media options are permitted for the Wilderness series fireplaces. The following Firelog sets are permitted for the Wilderness 44 series fireplaces:

.BIRCH LOG FIRELOG SETS ARE DIFFERENT FOR NG AND LP:

- Firelog sets for NG and LP have different SKUs. Please ensure you have correct SKU for desired gas type prior to ordering.
- LP logs do not contain nickel strands inside the logs. NG logs do contain nickel strands.

! NOTE: It can take up to 20 minutes for the flames to turn yellow.

! WARNING: The fireplace is not designed to burn real wood. Any attempt to do so could cause irreparable damage to the fireplace and may result in property damage, personal injury and/or loss of life.

The following items are included with the Birch Log Firelog set for the Wilderness 44 series fireplaces.

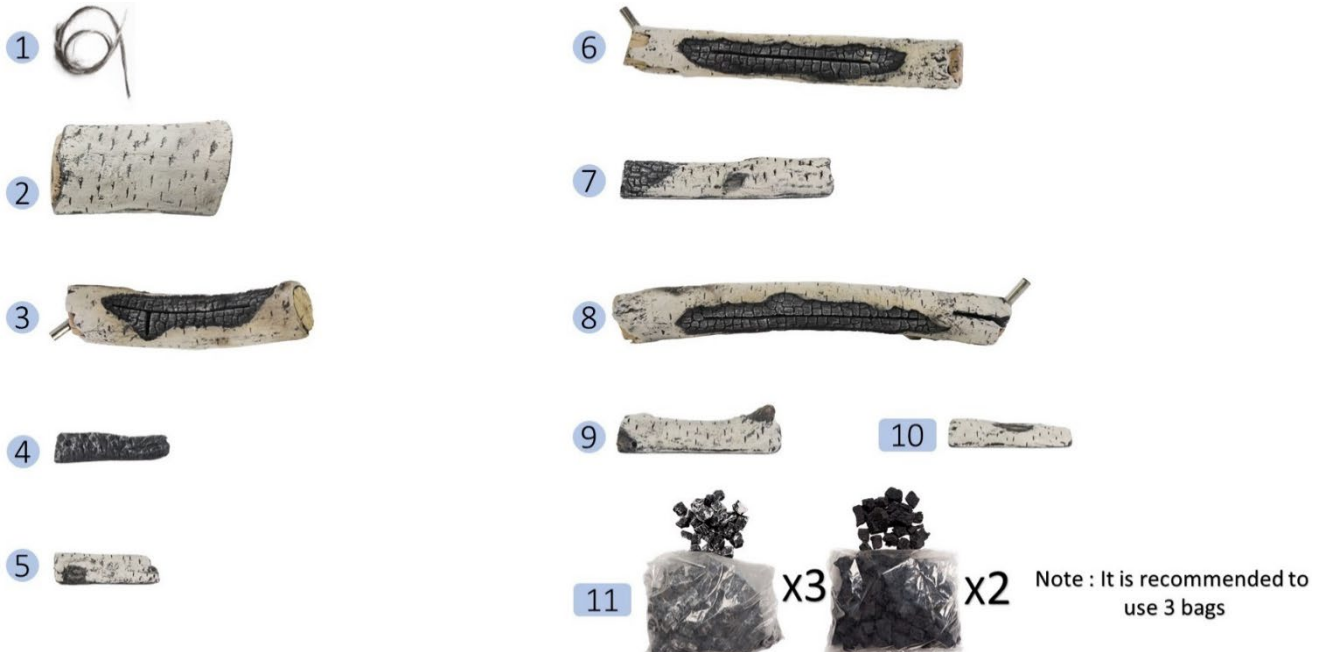

→ Birch Log Firelog Setup

Log placement of the Birch Log Firelog Set is crucial for optimal fireplace operation and safety purposes. Logs must be arranged as detailed in the following pages. No other arrangement is permitted. Alternative log arrangement will affect fireplace safety, operation, and performance. Setup can take up to 1 hour to complete. Handle logs gently to avoid paint damage.

STEP 1: Nickle Strands

1. Use your fingers to separate the nickel strands (supplied 2x20" long) as shown in the image below. It is recommended to cut the nickel strips into 10 equal strips to make it easier to separate them.



Left: Nickel strands as supplied | Right: Nickel strands ready to use

2. Place nickel strands on top of the burner holes. Keep nickel strands a minimum of 1 inch from the pilot.

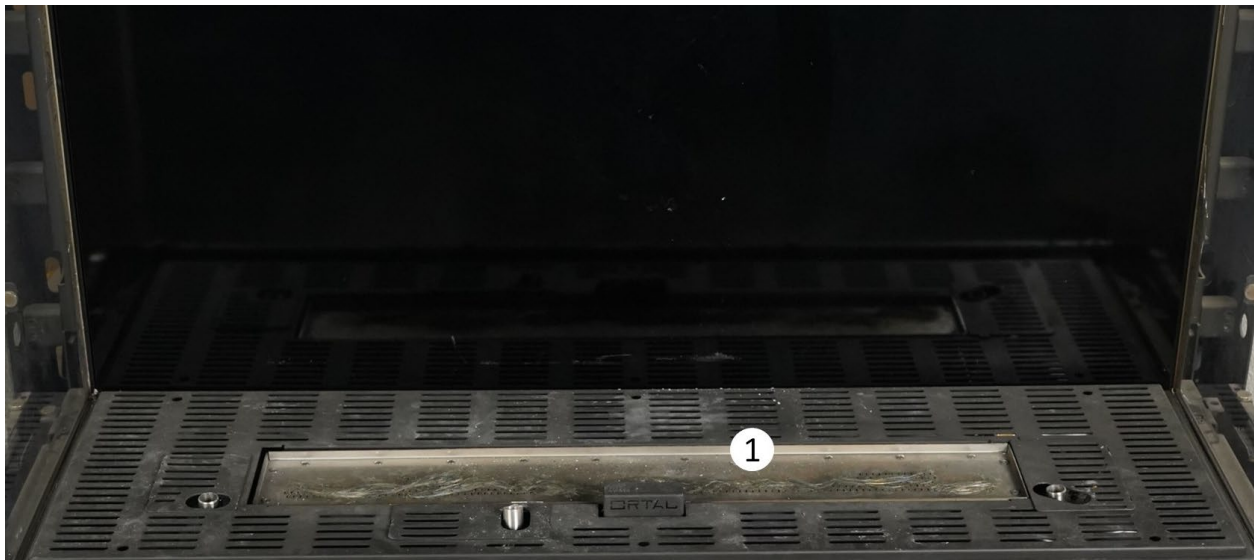

⚠ WARNING: For safety and optimal fireplace function, keep 1 inch around the pilot (behind pilot hood) completely clear of any media or debris.

Arrange firelogs as shown in Steps 2-10.

STEP 2

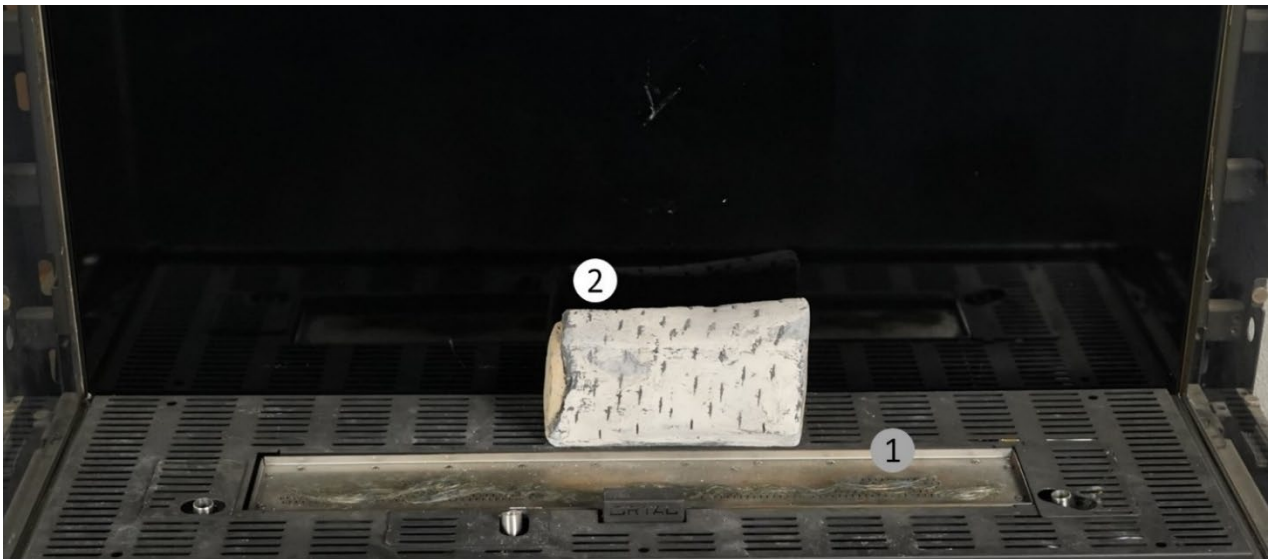

STEP 3

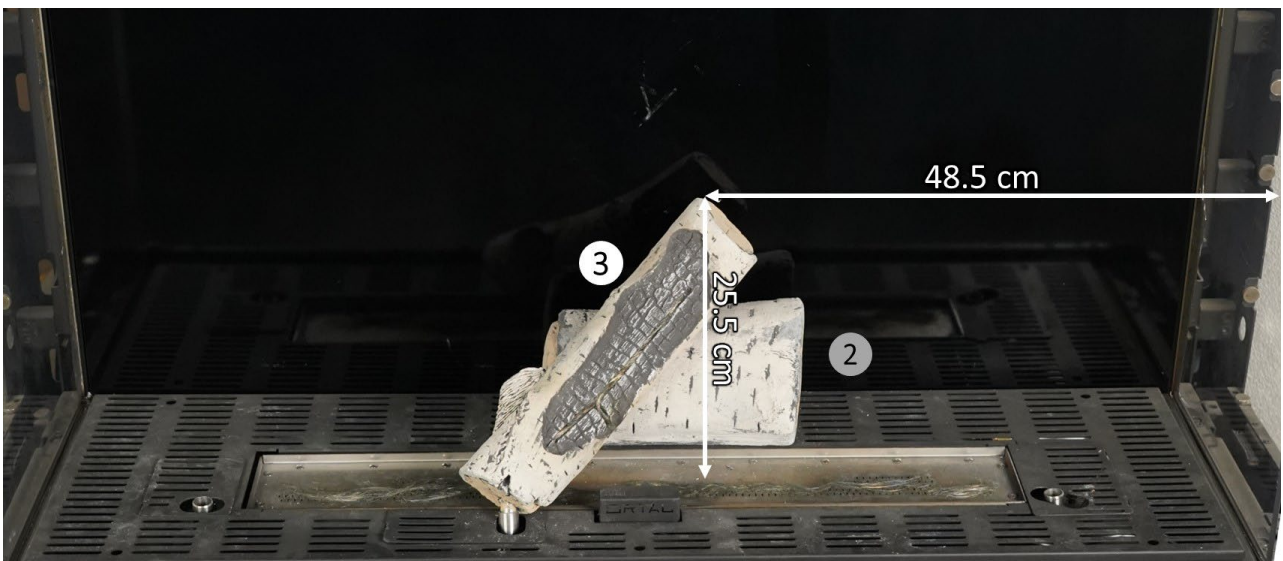

The base of log #3 can be adjusted to fit the position shown in pictures above (see "Log Base Position Adjustment" section for details).

STEP 4

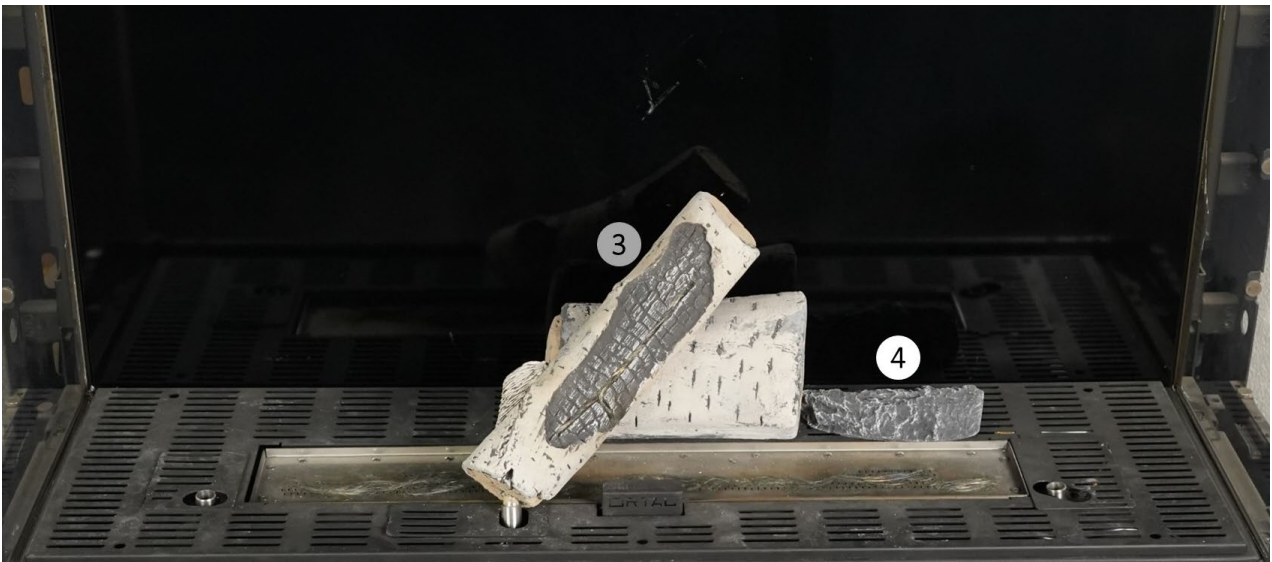

STEP 5

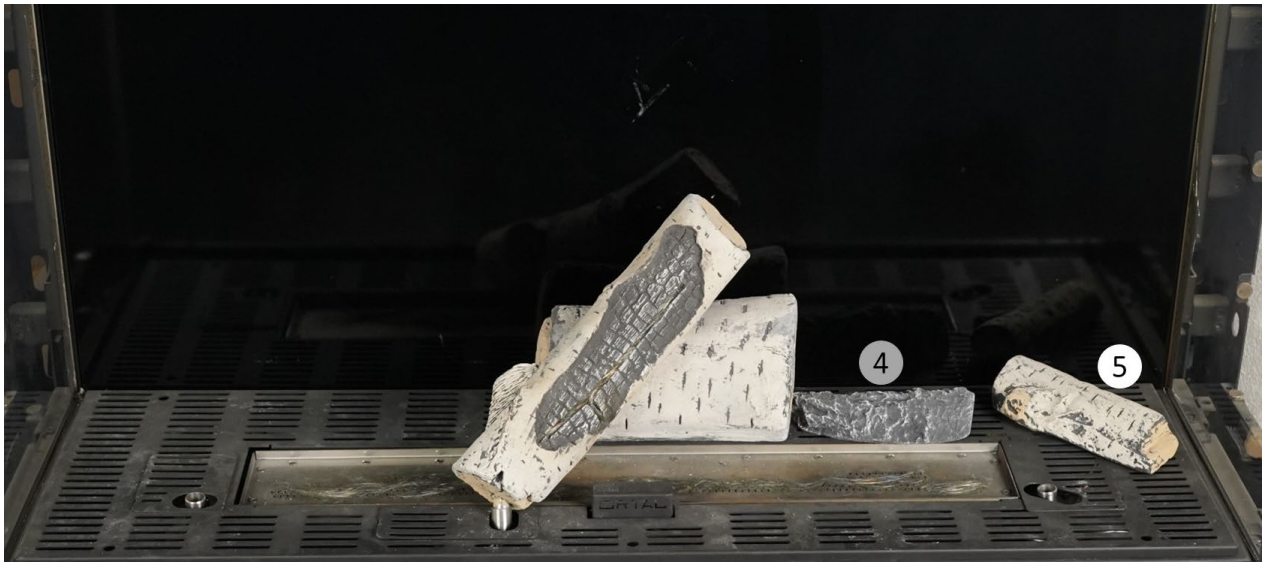

STEP 6

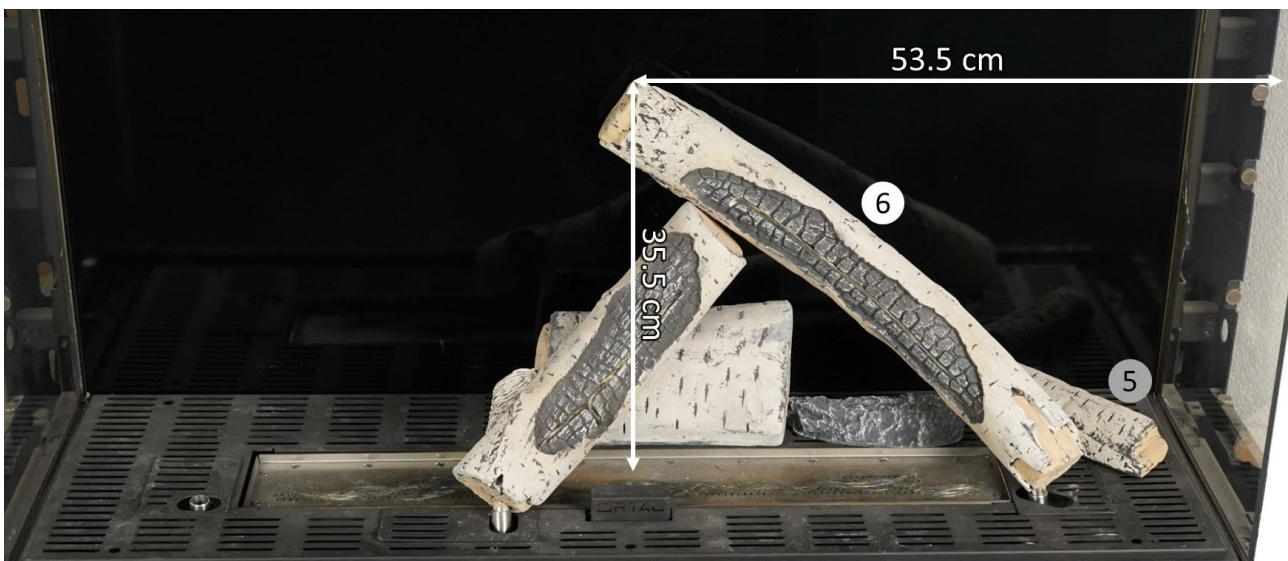

The base of log #6 can be adjusted to fit the position shown in pictures above (see “Log Base Position Adjustment” section for details).

STEP 7



STEP 8

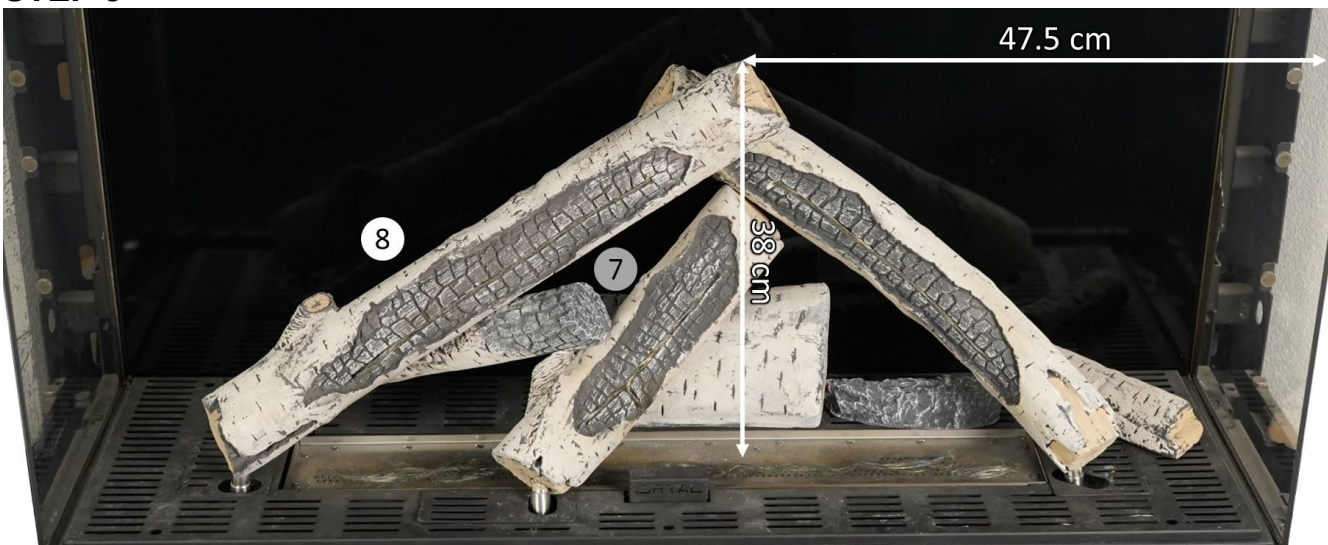

The base of log #8 can be adjusted to fit the position shown in pictures above (see “Log Base Position Adjustment” section for details).

STEP 9

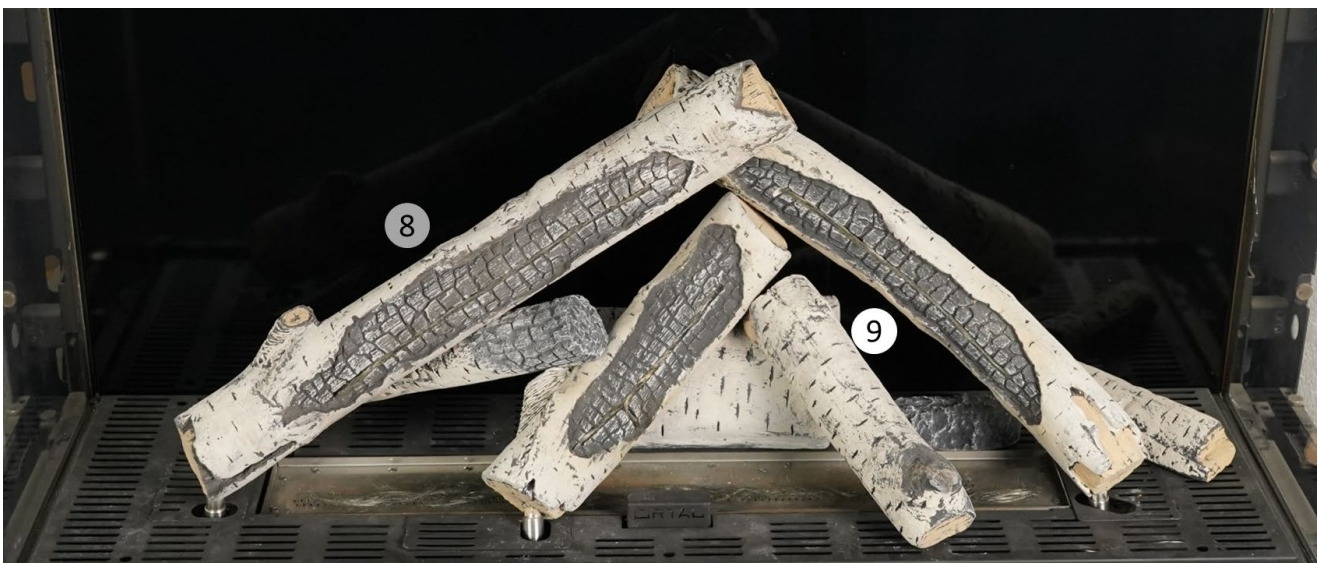

STEP 10



STEP 11

Add charcoal pieces to the bottom of the firebox. Do not cover any burner holes. Maintain minimum 1-inch clearance around the pilot behind pilot hood.



⚠ WARNING: For safety and optimal fireplace function, keep 1 inch around the pilot (behind pilot hood) completely clear of any media or debris.

⚠ WARNING: To prevent log breakage, follow these log instructions carefully. The gas logs ***MUST*** be supported by additional logs as directed as they were not designed to support their own weight solely from the gas supply tube.

Log Base Position Adjustment

Adjustment Instructions

! NOTE: The following images are for illustrative purposes only. Instructions apply to Front, Corner, and Three Sided models.

Step 1

Remove the front heat barrier (screen or glass) and inner front glass.

Step 2

Pull the logs up and remove from the fireplace, as shown in figure 1 below.

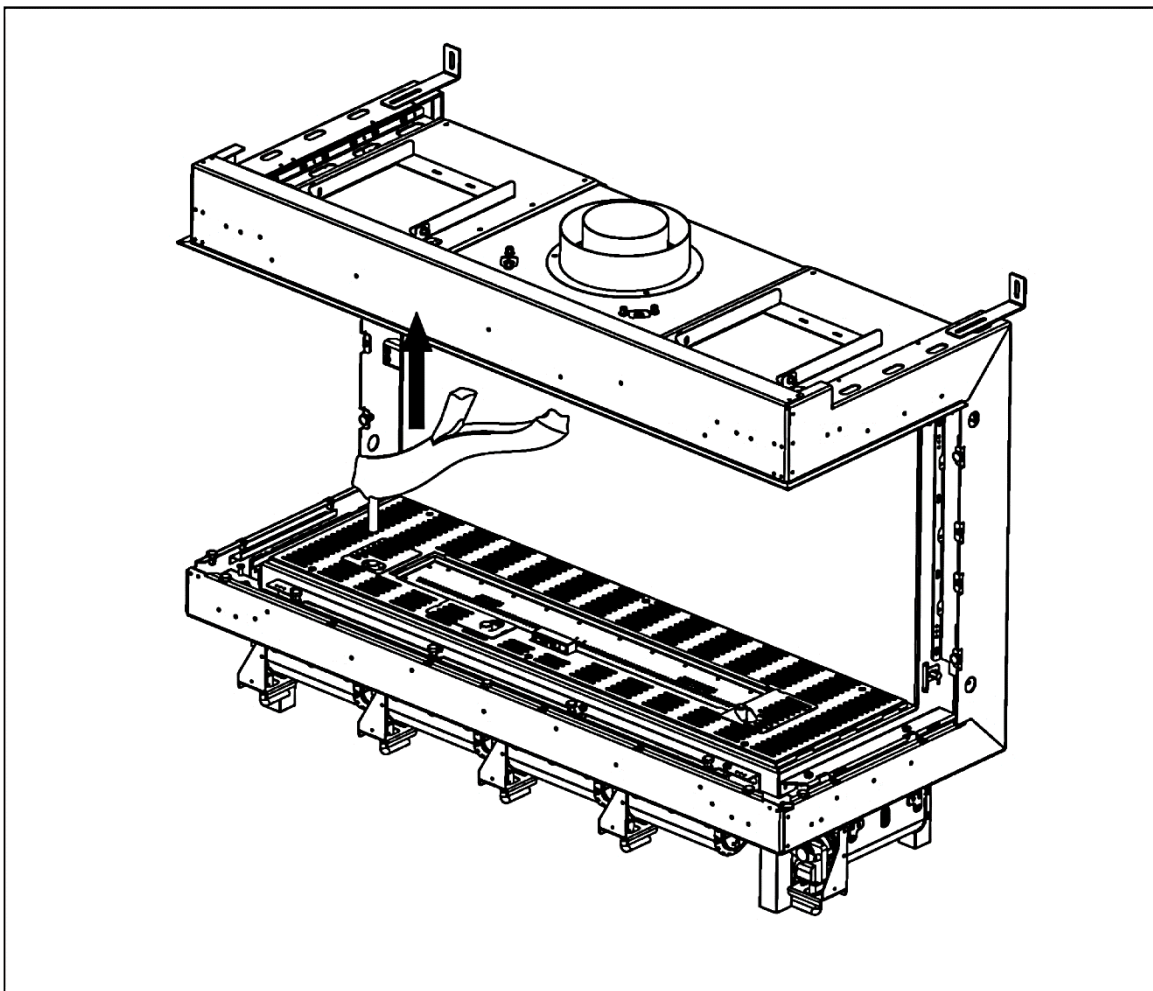

Figure 1

Step 3

Remove the grill covers as shown in figure 2 below.

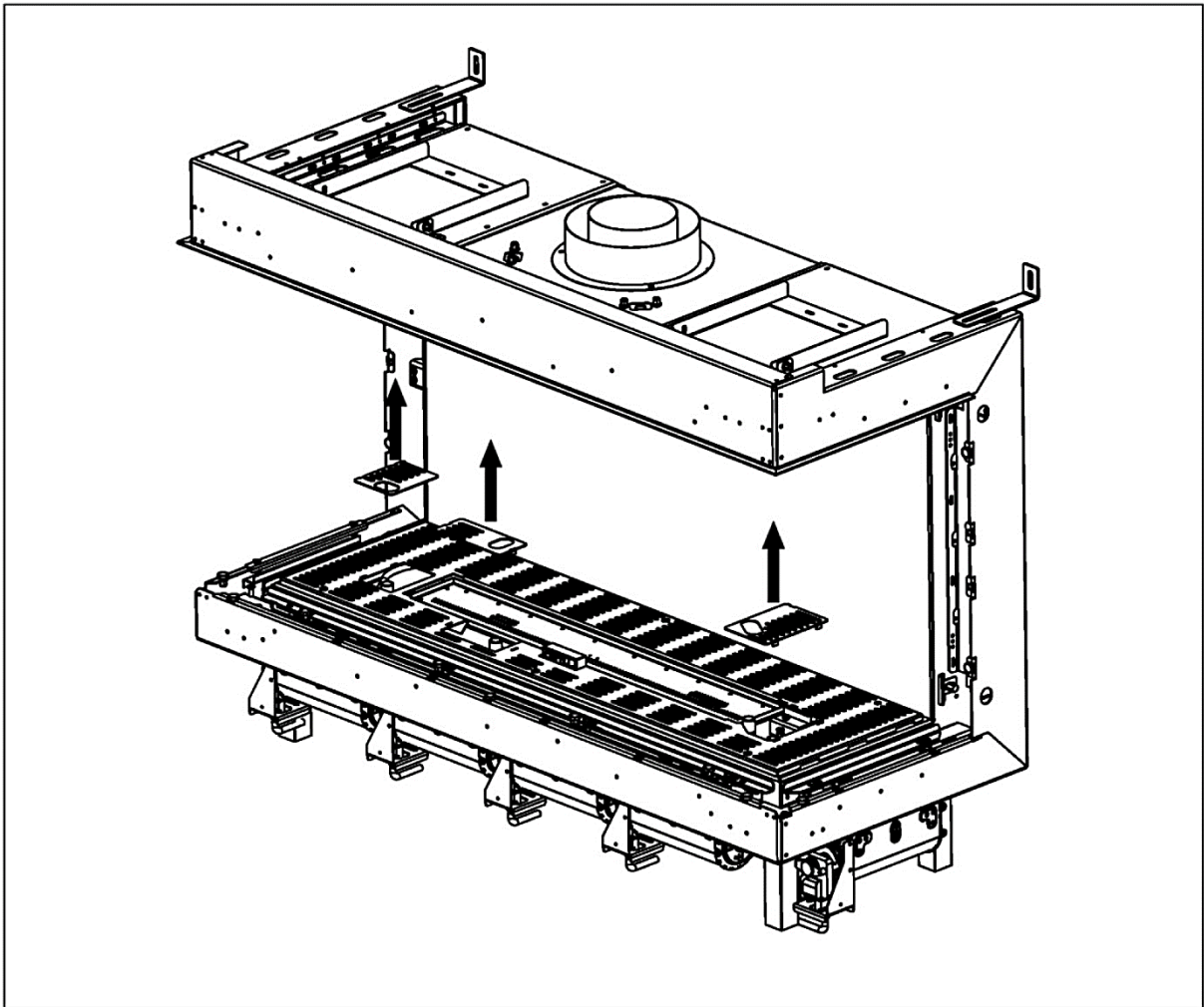

Figure 2

NOTE: Reassemble the system by performing Steps 1-3 in reverse.

Adjusting Log Position

Step 4

Using a screwdriver, loosen the log tube screw to change its orientation, as shown in figure 3 below.

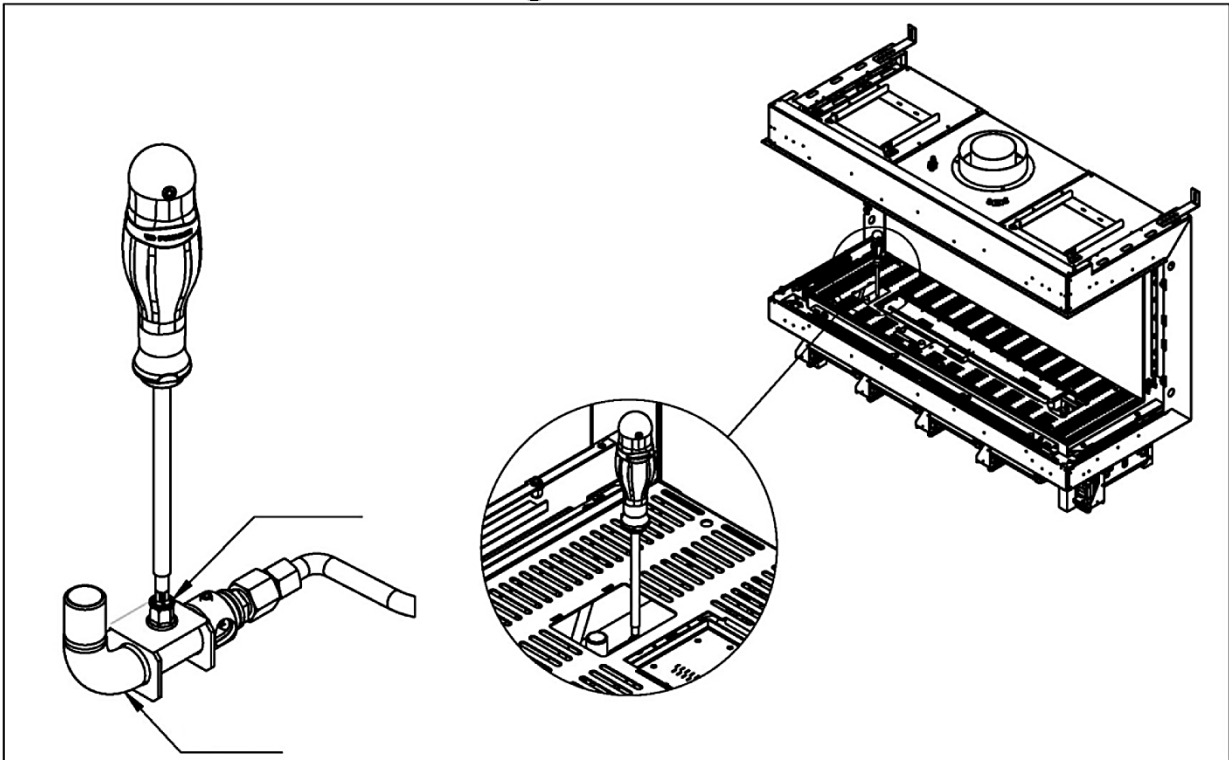

Figure 3

Step 5

Adjust the orientation as needed, as shown in figure 4 below, then re-tighten the screw.

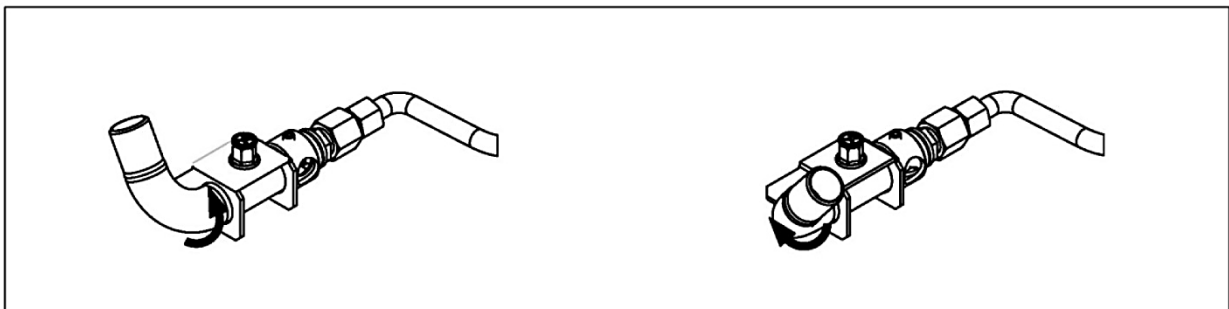

Figure 4

Log Base Aeration

Step 1

Using a 2.5mm Allen Key, loosen the aeration screw to change its position, as shown in figure 1 below.

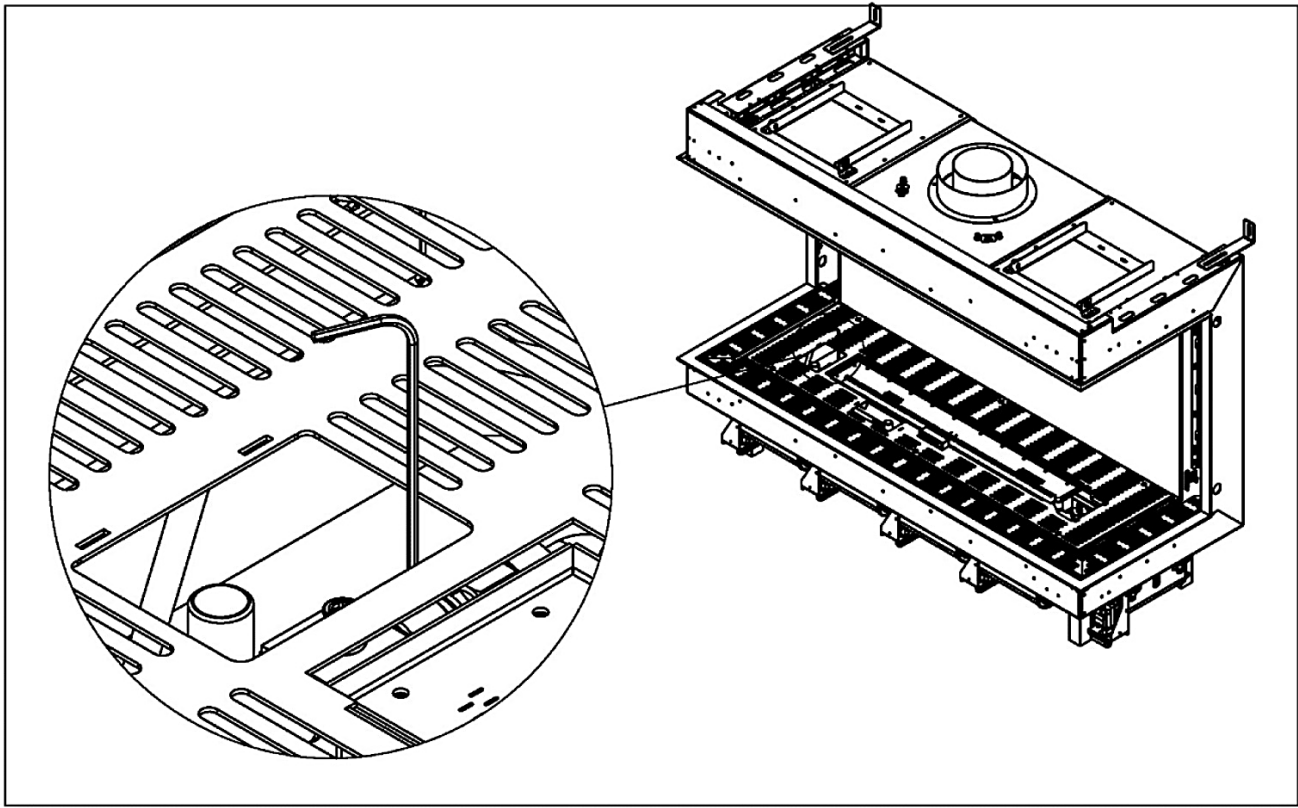

Figure 1

Step 2

Rotate the shutter to adjust the aeration to the gas tube, as shown in figure 2 below. Then re-tighten the screw.

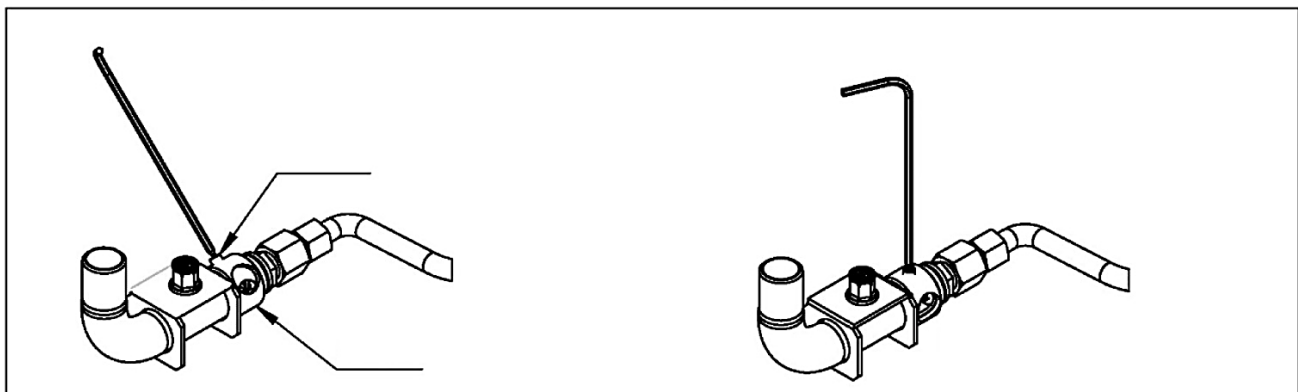

Figure 2

Servicing the Fireplace

Screen Removal

To remove the protective screen, follow the steps below:

STEP 1:

Using the vertical profile remover, which ships in the Brown Installation box, hook the top of the profile with the tool and pull to remove both side profiles.

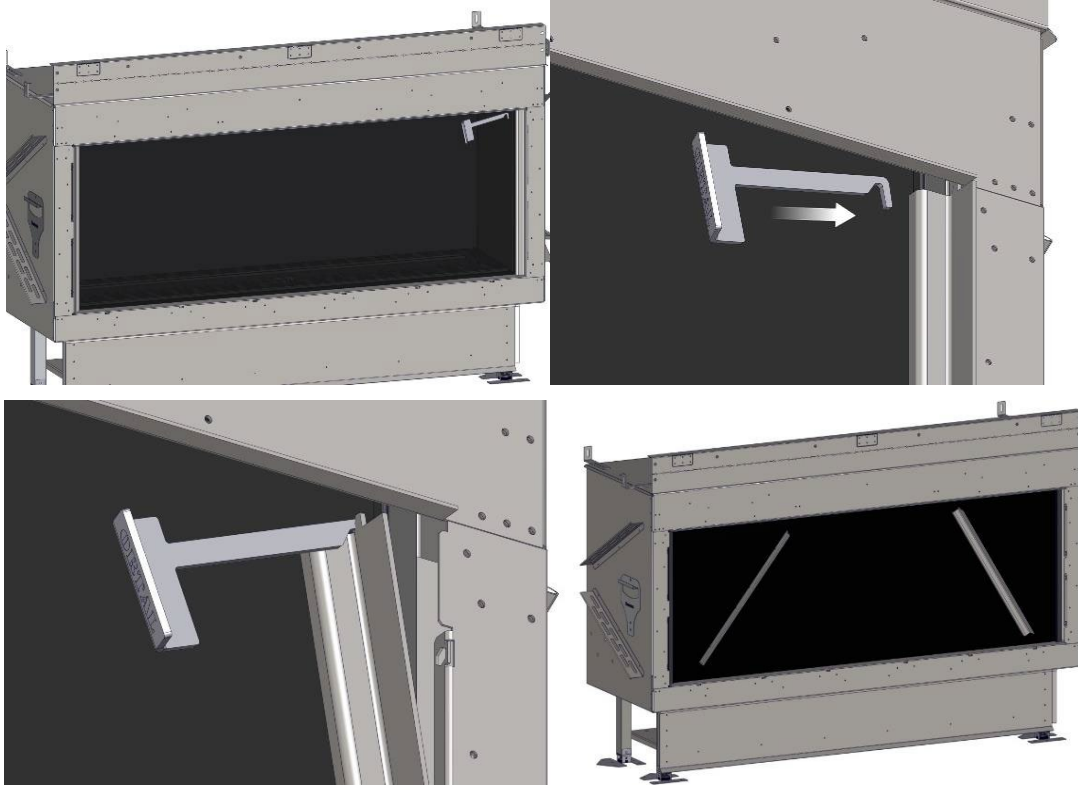

STEP 2:

Pull the horizontal profile up from the lower edge of the viewing area:

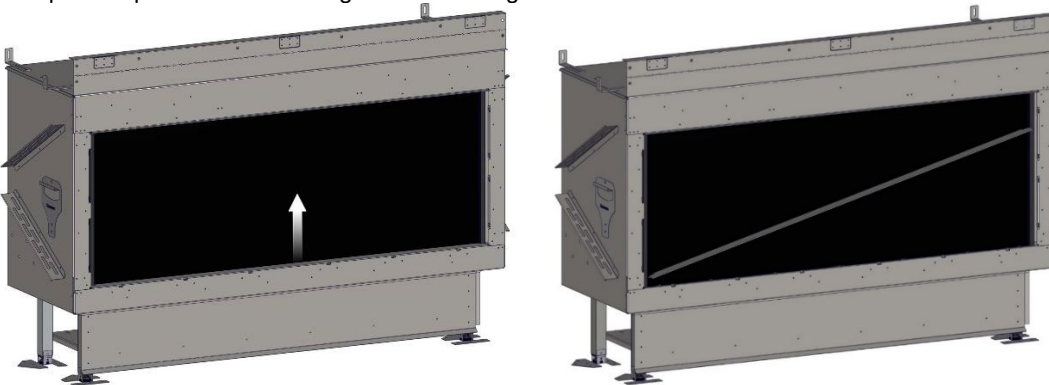

STEP 3:

Remove the M6 screw using a PH3 screwdriver as shown below:

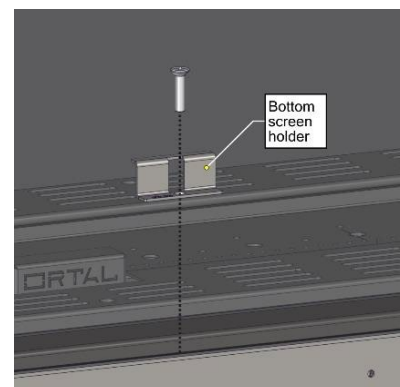
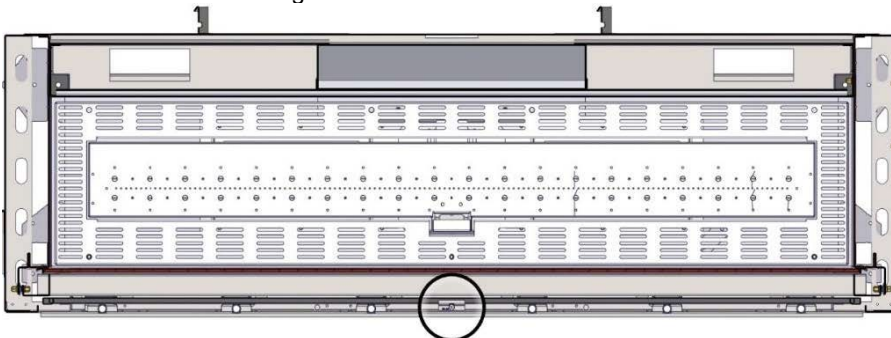

STEP 4:

At the top of the viewing area, push up the screen holder as shown below:

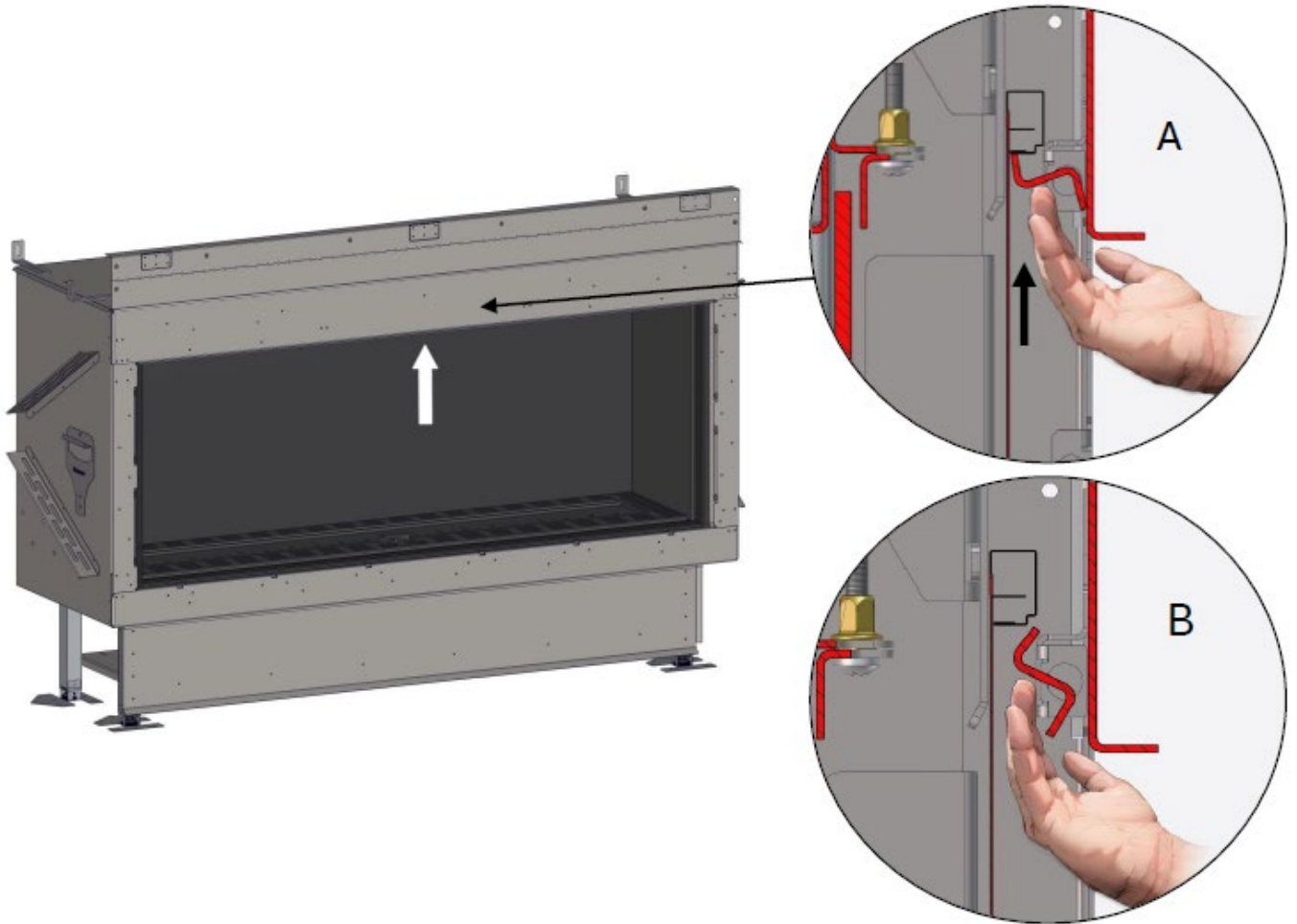

STEP 5:

Rotate the bottom of the screen out which will allow the top to drop out and the screen to be removed:



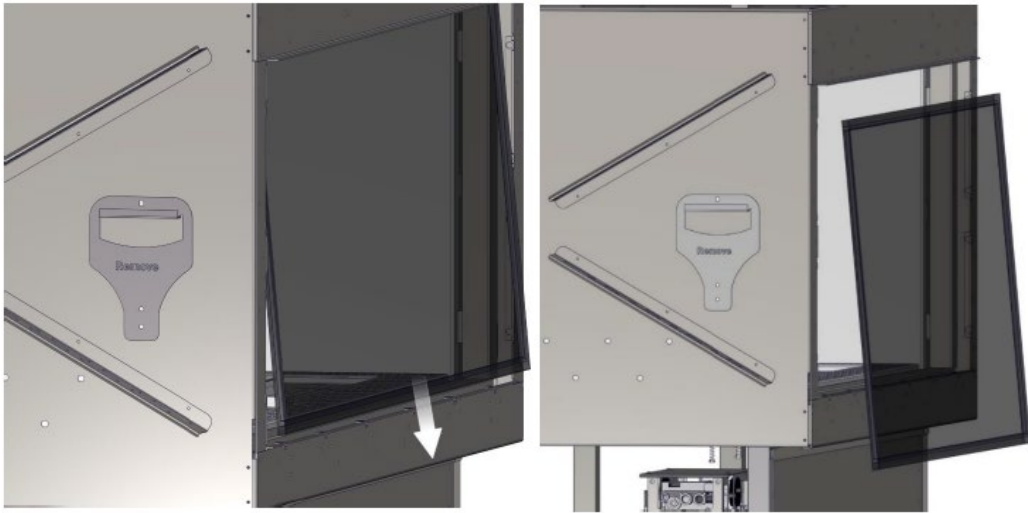

Glass Removal

To remove the glass, follow the steps below. **Note:** The external side and horizontal trim pieces & mesh have already been removed prior to step 1.

STEP 1:

Pull the inner vertical and horizontal trim pieces off the fireplace as shown below:

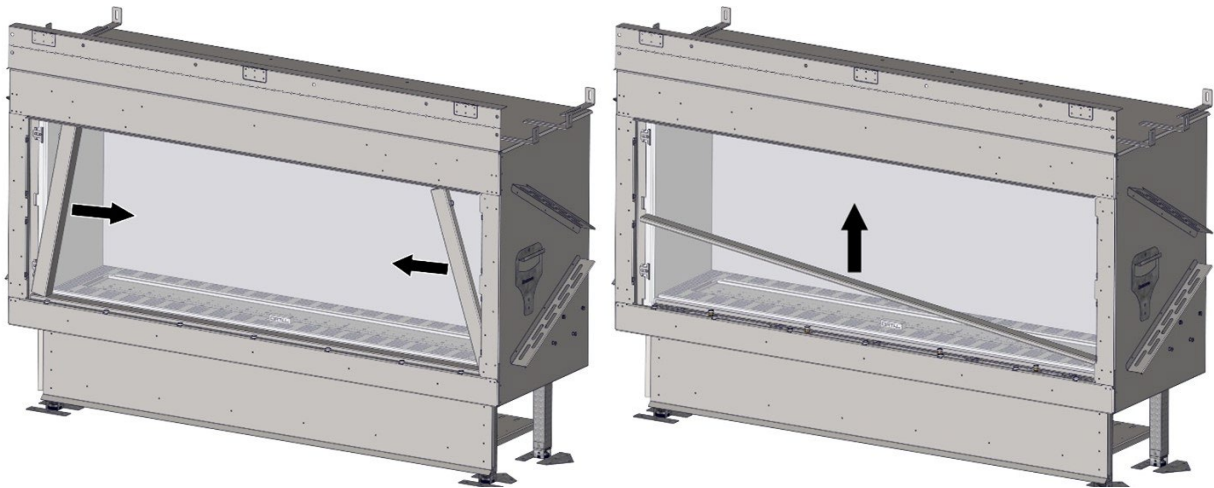

STEP 2:

Loosen the screws that are holding the top trim pieces in place:

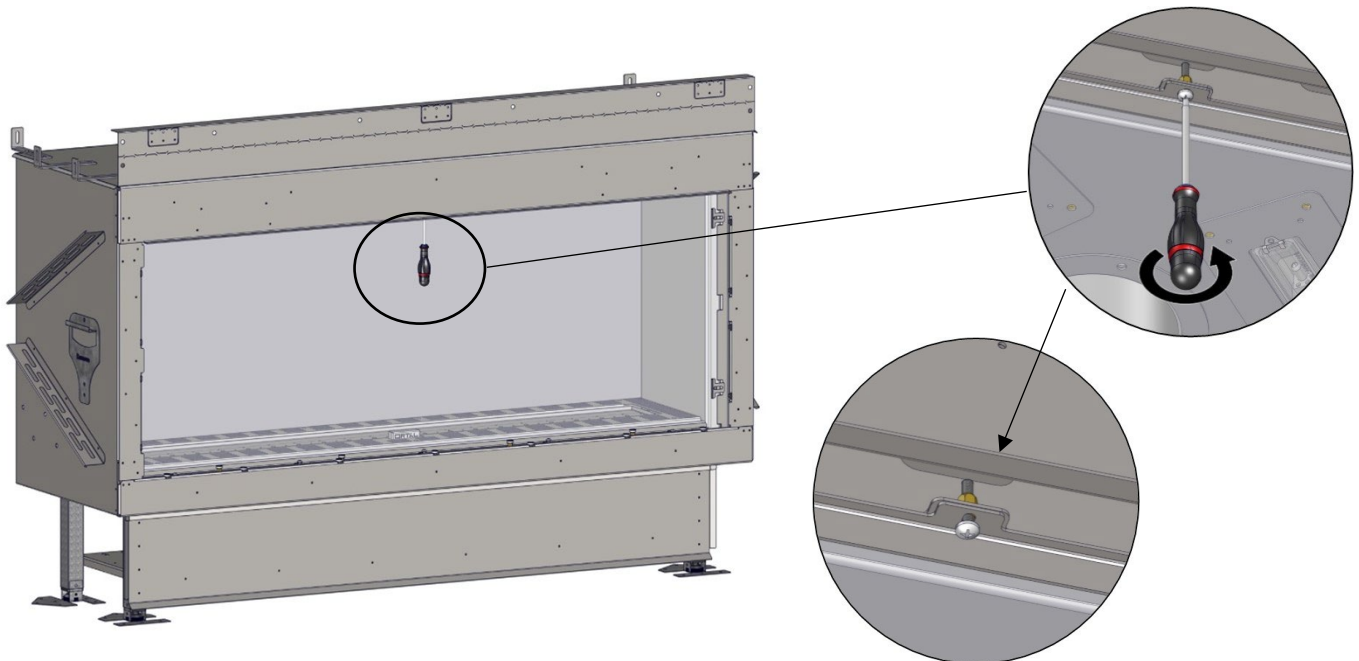

STEP 3:

Loosen the screws that are holding the bottom trim piece in place and slide the trim piece to remove:

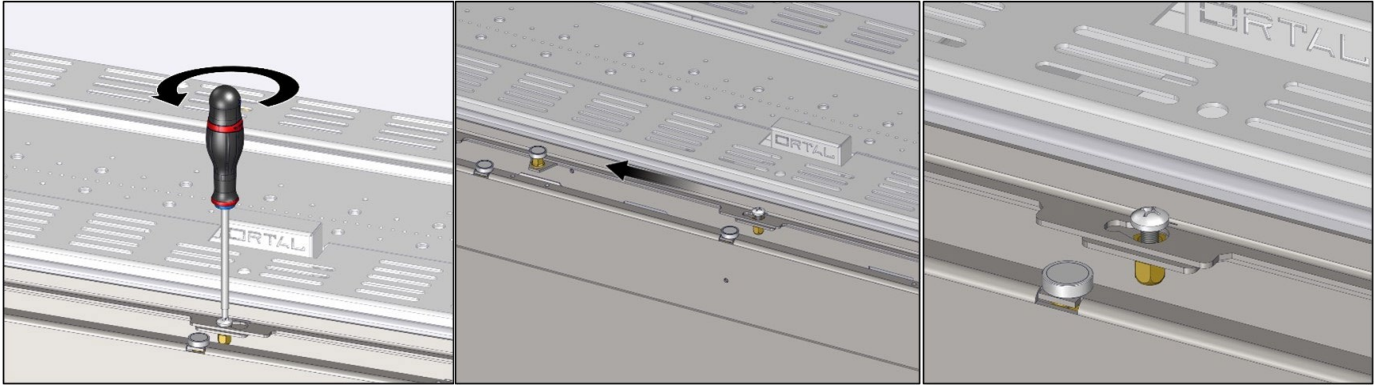

STEP 4:

Attach a suction cup to the middle of the glass, lift up and swing the bottom out to remove the glass:

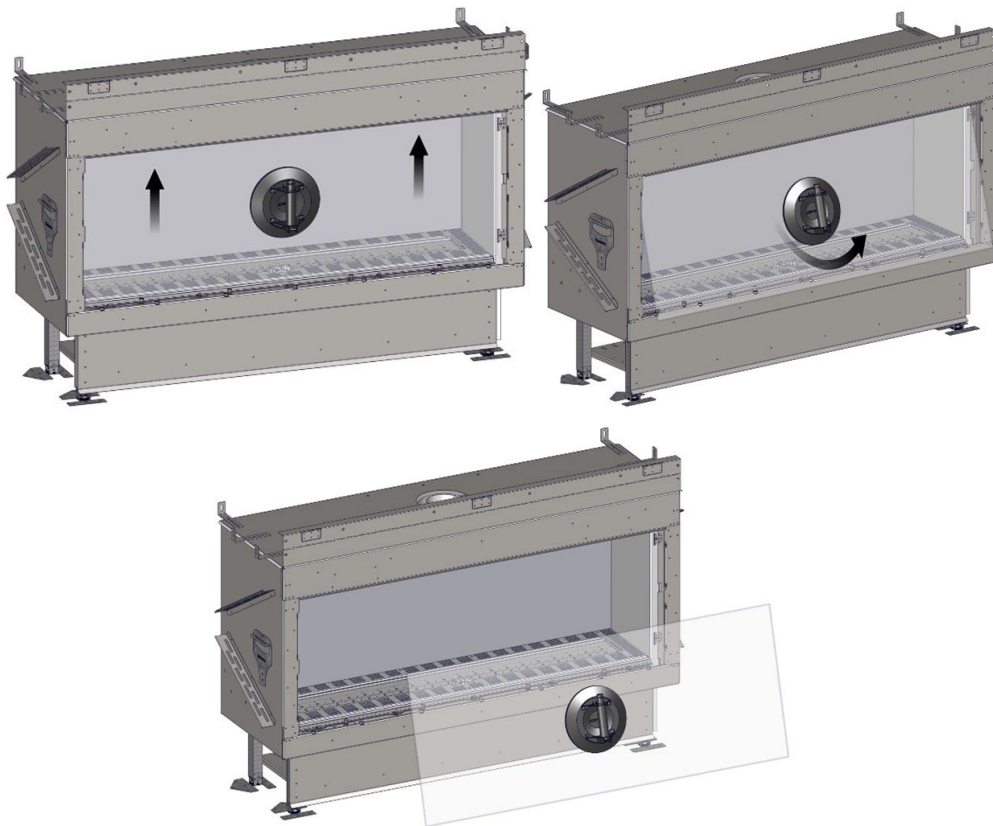

Service Box

There are two possible locations for the service box. Below are instructions on how to remove and service the unit components based on the location of the service box.

Service Box Installed on the Side

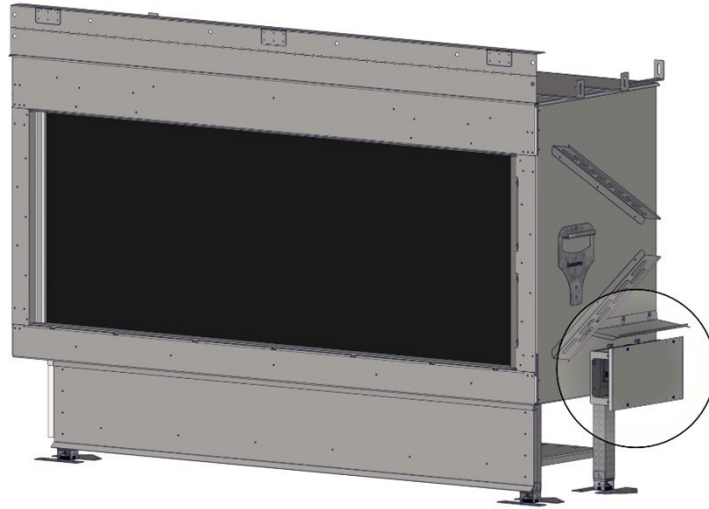

STEP 1:

Release the box cover screws using a PH1 screwdriver:

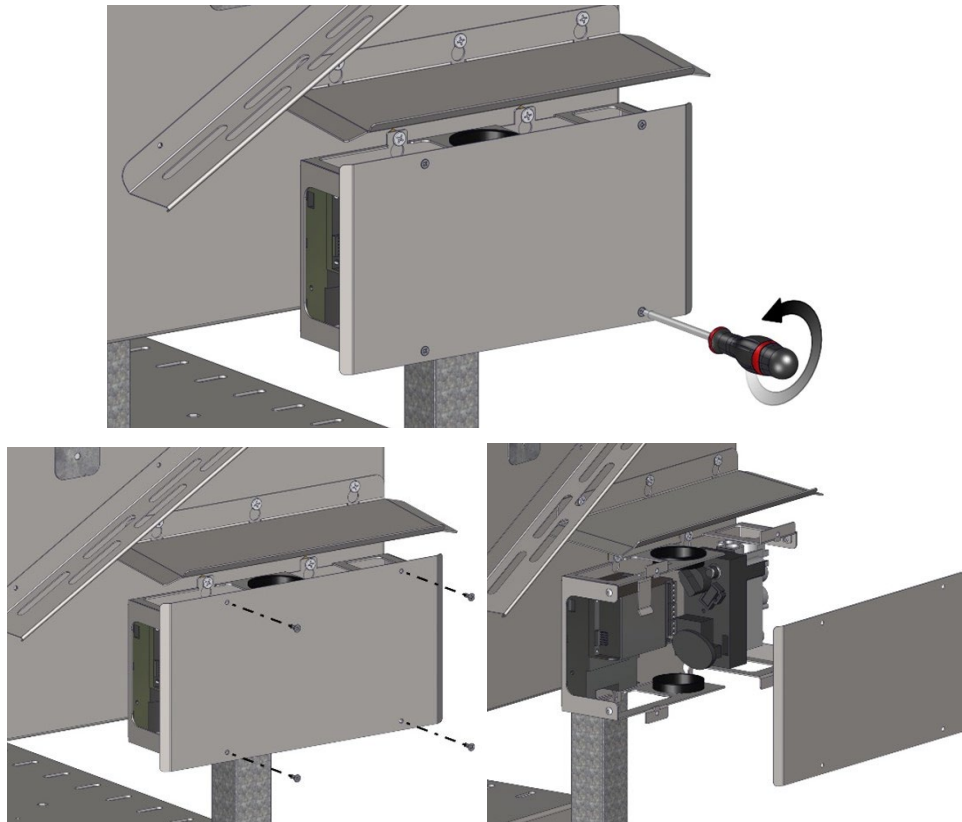

STEP 2:

Loosen the two box screws and slide the plate up to remove:

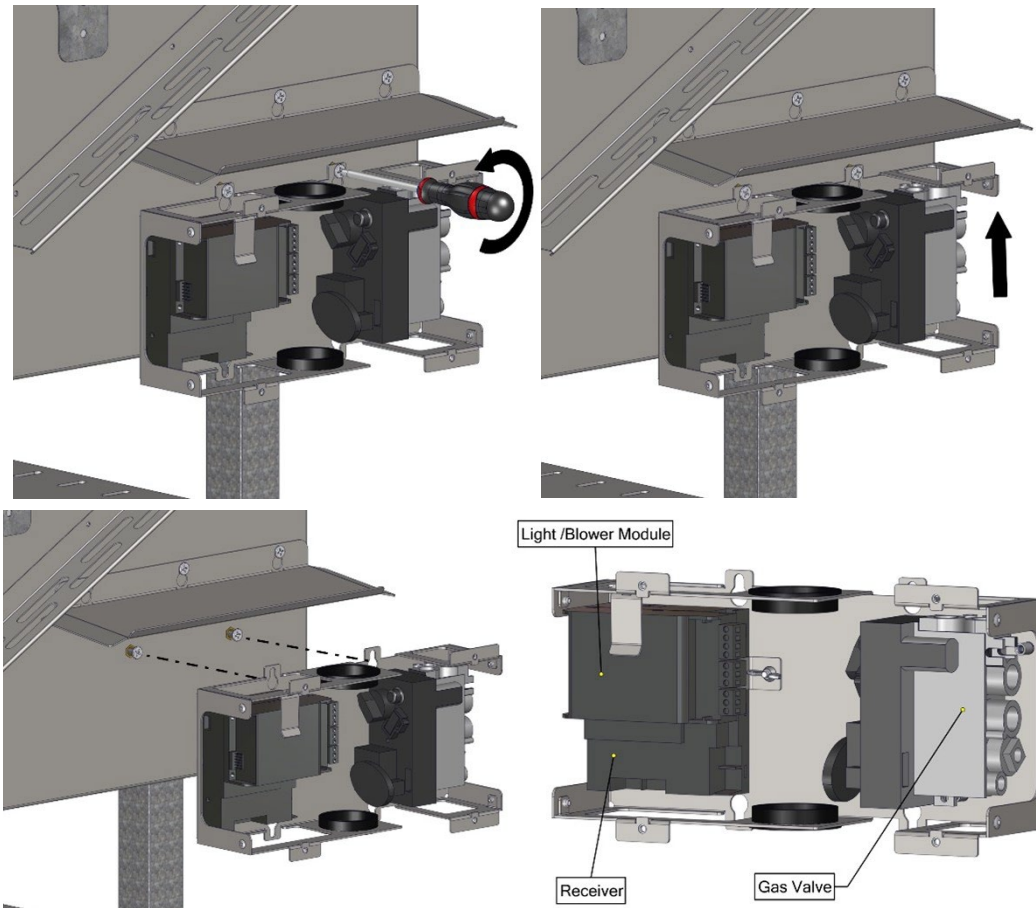

Service Box Installed Underneath the Burner

Unit can be serviced internally by removing the burner and grill:

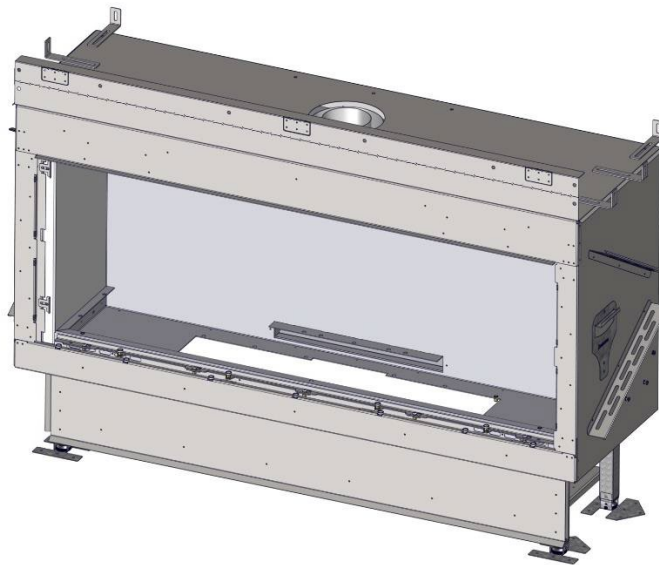

STEP 1:

Pull up the lock pin to disengage from the pin and rotate away from the box to unlock the components box:

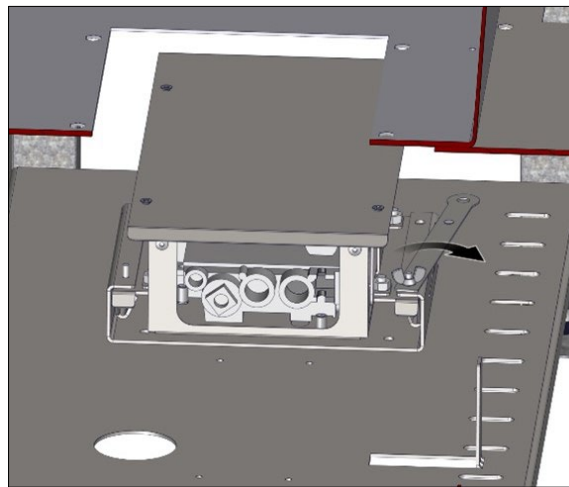
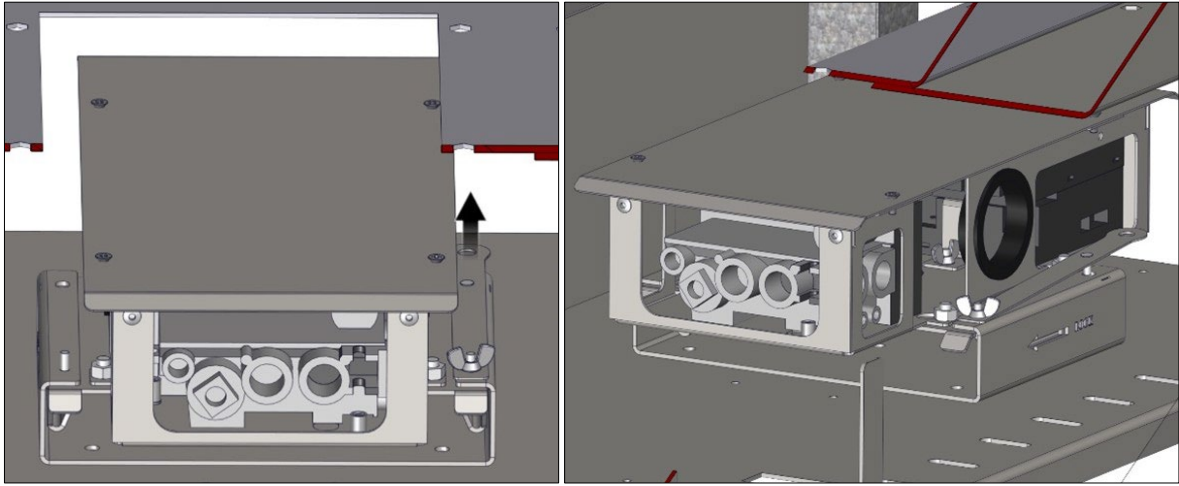

STEP 2:

Slide the box to the left to remove from the box holder and remove through the burner hole:

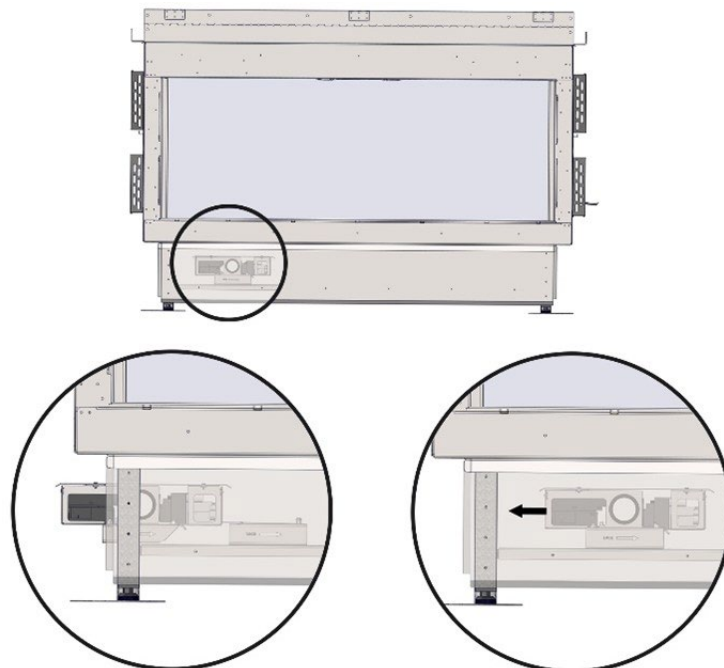

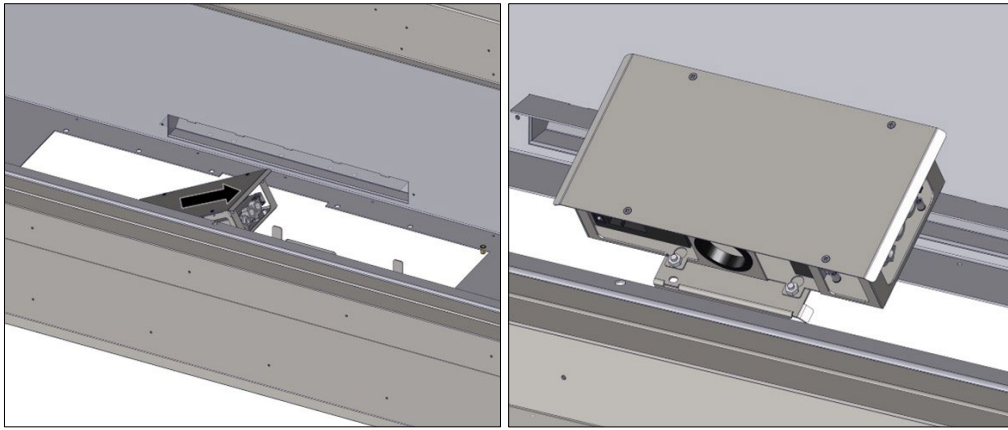

STEP 3:

Using a PH1 screwdriver, remove the screws holding the cover in place to access components:

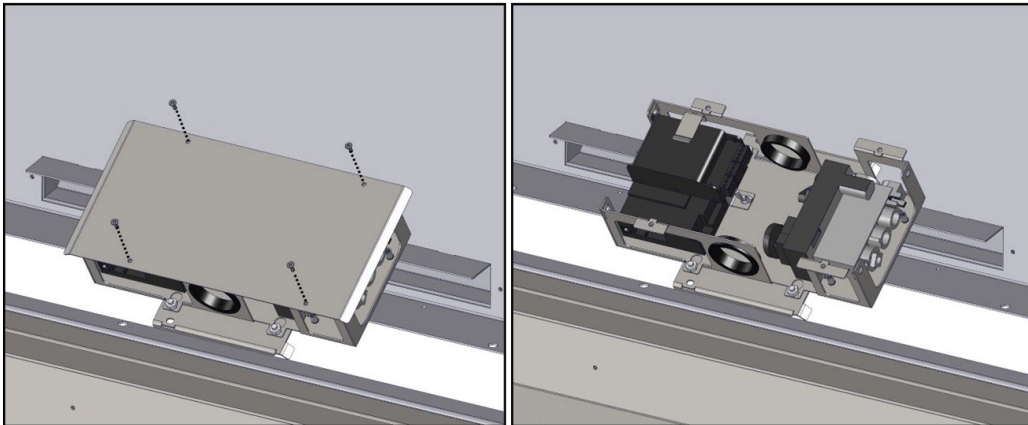

Operation

WARNING – Read these instructions carefully before lighting the fireplace.

- 10-Button Remote Control Handset (standard option, always included with the fireplace)
- Wall Switch (optional accessory)

IMPORTANT: The 10-Button remote control handset is always included with the fireplace regardless of which operation option is chosen. **DO NOT DISCARD.** The 10-Button remote must be always kept within 26 feet of the fireplace and in a dry safe place from outdoor elements.

NOTES:

- The wiring of valve and receiver must be completed before starting ignition. Failure to do so could damage the electronics.
- Fireplaces with interior lighting feature must operate using 120v and therefore will not operate during a power failure.
- Batteries must be kept within their recommended temperature limits (32°F to 131°F).

10-Button Remote Control Handset

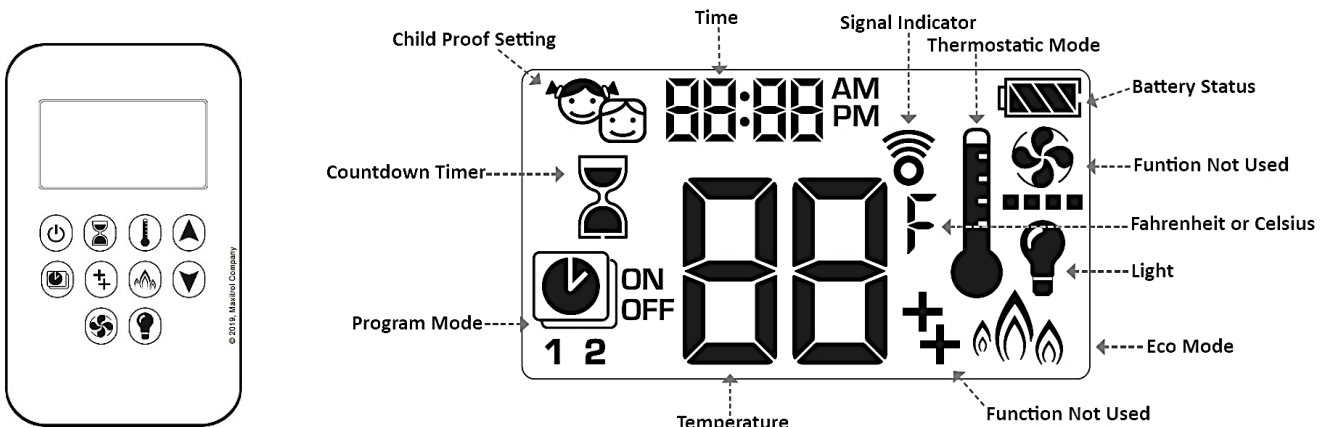

© 2019, Maxitrol Company

Control Option	Radio Frequency	Power Supply	
10-Button Handset	918.0 MHz (U.S. & Canada)	2 x 1.5V AAA batteries (quality alkaline recommended)	Replace batteries after 2 years or when low battery indicator appears on handset display
IMPORTANT: For safety/communication purposes, 10-button handset must be located within 26 feet of the receiver.			

NOTE: Any device that functions using the same radio frequency as the handset will be affected when handset is in use.

Operating Instructions

Instructions for operating the 10-Button Handset are shown below. For more in-depth instructions, please refer to the “Homeowner’s Fireplace Operation Manual” or “Remote Operation Instructions”.

NOTE: Some options on the remote may not be available for all fireplaces.

Turning the Fireplace On

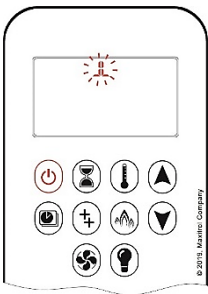

1. Press the  button until you hear continuous beeping, and a blinking series of lines confirms the start sequence has begun; release buttons.
2. Main gas flows once pilot ignition is confirmed.
3. The system automatically goes into Manual Mode after main burner ignition.

NOTE: When pilot ignition is confirmed, motor turns automatically to maximum flame height.

NOTE: If the Timer function has been set and the fireplace is manually turned on, the Timer function will need to be reset.

Turning the Fireplace Off





1. Press the  button to turn the fireplace off.

NOTE: The fireplace may be turned on again after the OFF icon stops flashing.

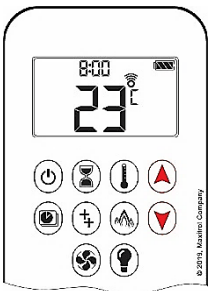
Flame Height Adjustment



1. To increase flame height, press and hold the  button to desired flame height.
2. To decrease flame height, or to set fireplace to pilot flame only, press and hold the  button.

Wall Switch

In order to utilize a wall switch, a weatherproof enclosure must be incorporated into the chase to protect the switch from water damage.

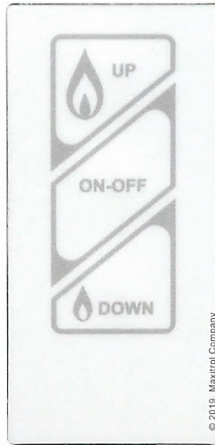

Control Option	Radio Frequency	Power Supply
Wall Switch	N/A	N/A

IMPORTANT: For safety/communication purposes, the 10-button handset must be located within 26 feet of the receiver.

Operating Instructions

Turning the Fireplace On/Off



ON/OFF

ON: Press and hold the **ON-OFF** button until two short beeps confirms the start sequence has begun; release button.

OFF: Press the **ON-OFF** button.

Flame Height Adjustment

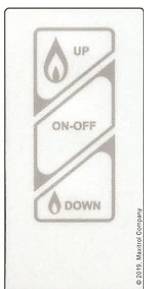

Flame Up

Flame Down

INCREASE: To increase flame height, press and hold  (up flame) button.

DECREASE: To decrease flame height, press and hold  (down flame) button.

Holding the  (down flame) button long enough sets the fireplace to pilot flame (Standby Mode).

Fireplace Maintenance

General Maintenance

All servicing, maintenance, interior cleaning and handling of the fireplace, parts and glass must be performed by an authorized Ortal dealer service technician only.

Servicing

- Turn off the gas and electricity **BEFORE** servicing the fireplace.
- It is recommended that a routine inspection is performed at the beginning of each heating season.
- When removing glass from multisided fireplaces, only one side of glass can be removed at a time. Glass must be re-installed before removing glass from a different side.

Metallic Noise

- Noise is caused by metal expanding and contracting as it heats up and cools down, like noise produced from a furnace. The noise does not affect the operation or longevity of the fireplace.
- These minor expansion, contractions or movement of parts causing noise are normal. Complaints related to these noises are not covered by warranty.

Burner and Vent Inspections

- Periodic checks should be made of the burner for correct position and condition. Visually check the flame of the burner, making sure that the flames are steady.
- The vent system must be inspected before use. Annual inspection must be scheduled to ensure the flow of combustion and ventilation air.

Submerged Parts

- Do not use the fireplace if any part has been under water, or if you suspect that it may have been under water. The Ortal dealer service technician must inspect and, if necessary, replace any parts of the control system and any gas controls which have been under water.

Handling the Glass

Inner glass panel is 5mm ceramic glass. Ceramic glass must be provided by Ortal.

- When removing glass from multisided fireplaces, only one side of glass can be removed at a time. Glass must be re-installed before removing glass from a different side.
- **NEVER** operate the fireplace without the glass properly secured in place.
- Only an Ortal certified installer is authorized to remove the glass. Glass must be removed using an 8-inch glass-handling suction cup. Lower the glass to rest in a safe place to prevent damage to the glass edges.

Cleaning the Fireplace

- Only an Ortal dealer service technician can open the fireplace to clean interior surfaces.
- **ALWAYS** turn off the gas valve before cleaning.
- Do **NOT** clean when hot. Make sure fireplace has had time to cool prior to cleaning any surface or component, interior or exterior.
- Keep the fireplace clean by brushing and/or vacuuming at least once a year. This can only be performed by an Ortal dealer service technician.
- When removing glass from multisided fireplaces, only one side of glass can be removed at a time. Glass must be re-installed before removing glass from a different side.
- Clean the glass when it starts to look cloudy. Use a damp cloth for cleaning the fireplace and the door.
- Verify correct operation after servicing.

Maintenance Frequency and Equipment Checklist

- Under normal circumstances, the factory recommendation is to have the fireplace serviced at least once a year. Fireplaces meeting the following conditions should have more frequent service:
 - Fireplaces installed in commercial/public spaces should be serviced every 3 months.
 - Fireplaces installed in climates near the ocean or in other settings where corrosion buildup is more likely should be serviced every 6 months.
- Thermocouple Maintenance:
 - The thermocouple should be replaced annually or as needed in all commercial installations, and in any residential fireplace where the fireplace is operated for an average of 10 hours or more per day.
 - For all other installations, the thermocouple should be replaced every three years or as needed.
 - Periodically perform visual checks of the pilot and burner flames. The pilot should be a steady flame, touching the electrode/thermocouple. The burner flames should be blue at the base with a combination of blue/yellow at the body and tips.

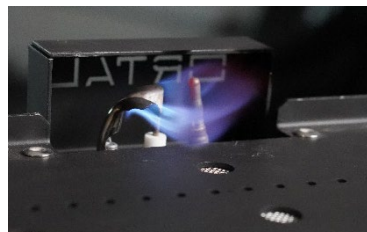
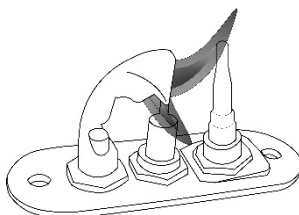

© Ortal 2026
Version 2.1, March 2026
SKU: KPMANWILDOUT44V2.1

Ortal USA
2152 Citygate Drive, Columbus, OH 43219
T: (818) 238-7000 | F: (818) 678-0541
info@ortalheat.com | www.ortalheat.com