

# ORTAL<sup>®</sup>

## Installation and Operation Manual Wilderness Traditional Series

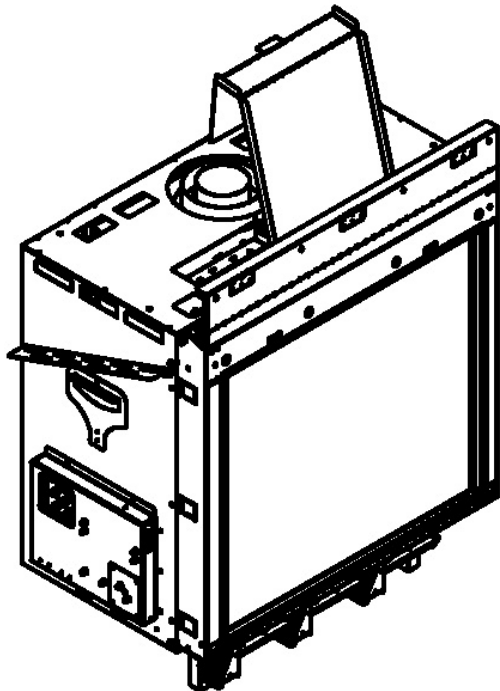
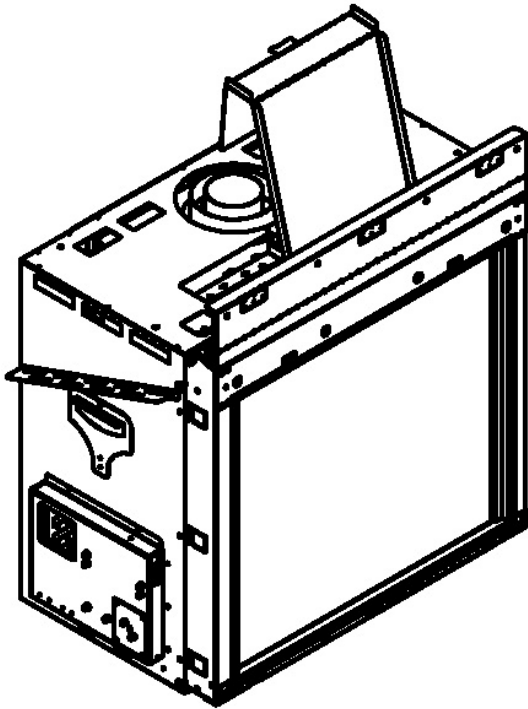

### Manufacturer Update Serial Number 33472 and Forward

#### ⚠️ WARNING:

#### FIRE OR EXPLOSION HAZARD

Failure to follow safety warnings exactly could result in serious injury, death, or property damage

- DO NOT store or use gasoline or other flammable vapors and liquids in the vicinity of this or any other appliance.
- What to do if you smell gas:
  - DO NOT try to light any appliance.
  - DO NOT touch any electrical switch. DO NOT use any phone in your building.
  - Leave the building immediately.
  - Immediately call your gas supplier from a neighbor's phone. Follow the gas supplier's instructions.
  - If you cannot reach your gas supplier, call the fire department.
- Installation and service must be performed by a qualified installer, service agency, or the gas supplier.

## ! DANGER



HOT GLASS WILL  
CAUSE BURNS.

DO NOT TOUCH GLASS  
UNTIL COOLED

NEVER ALLOW CHILDREN  
TO TOUCH GLASS.

A barrier designed to reduce the risk of burns from the hot viewing glass is provided with this appliance and must be installed for the protection of children and other at-risk individuals

### Wilderness Traditional Series:

Wilderness Traditional 36

Wilderness Traditional 42



## Safety Information and Warnings

### **IMPORTANT NOTE: LOCAL CODE**

Local codes and regulations that are more stringent than the requirements in this manual take precedence over Ortal requirements.

### **WARNING: REVIEW ALL WARNINGS**

Be sure to review all safety warnings and installation guidelines contained in this manual. Consider installation location, vent configuration, clearances, structural requirements, framing and finish materials, and local codes. ALL warnings and instructions apply to all products manufactured and distributed by Ortal.

### **WARNING: DO NOT OPERATE FIREPLACE IF:**

The glass is NOT properly secured in place; Connection points are not sealed (for fireplaces with glass-to-glass connections); Glass is cracked; You smell gas; Any part of the fireplace has been under water; You have any doubt about safe operation of the fireplace; Or if any part has been under water, do not use the fireplace. Immediately call a qualified, professional service technician to inspect the fireplace and to replace any parts of the control system and any gas controls which have been under water.

### **WARNING: ELECTRICAL GROUNDING**

All electrical connections must be properly installed, insulated, and secured to avoid potential **ELECTRICAL SHOCK** and **FIRE HAZARD** and malfunction of the system. Consult local building code requirements. In the absence of local codes, refer to the National Electric Code, ANSI/NFPA 70, or the Canadian Electric Code, CSA C22.1.

### **WARNING: MATERIAL USAGE**

All materials and objects used to carry out the installation must be certified/approved or specified by Ortal and are suitable for use. Do NOT install the system with different materials or objects than those approved for installation by Ortal.

### **WARNING: INSTALLATION AND SERVICE**

Installation and repairs on the fireplace and vent system must be done by an authorized Ortal qualified installer service agency or gas supplier. If these components are not installed by an authorized Ortal dealer/installer, the warranty of all components will be void and Ortal will not be responsible for any damage caused by improper installation. The fireplace should be inspected before use and at least annually by a professional service person. More frequent cleaning may be required due to excessive lint from carpeting, bedding material, etc. Control compartments, burners and circulating air passageways of the fireplace must be kept clean. Any alteration to the product can cause soot or carbon to form and may result in damage. This damage and any other damage that results from not following the instructions outlined in this manual is not the responsibility of Ortal.

### **WARNING: HEAT BARRIER**

A barrier designed to reduce the risk of burns from hot viewing glass is provided with this fireplace and shall be installed. The fireplace **MUST** not be used without the heat barrier in place. If the barrier becomes damaged, the barrier shall be replaced with the manufacturer's barrier for this fireplace. **Any safety screen, guard, or barrier removed for servicing the fireplace must be replaced before operating.**

### **WARNING: FIREPLACE TEMPERATURE**

Due to hot temperatures, the fireplace should be located out of traffic and away from furniture and draperies. Children and adults should be alerted to the hazards of high surface temperature and should stay away to avoid burns or clothing ignition. Clothing or other flammable material should not be placed on or near the fireplace. **Young children should be carefully supervised when they are in the same room as the fireplace.** Toddlers, young children, and others may be susceptible to accidental contact burns. A physical barrier is recommended if there are at-risk individuals in the house. To restrict access to a fireplace or stove, install an adjustable safety gate to keep toddlers, young children, and other at-risk individuals out of the room and away from hot surfaces.

### **WARNING: GLASS HANDLING**

Only an Ortal certified installer is authorized to remove the glass using an 8-inch glass-handling suction cup.

### **WARNING: INSTALLATION AND OPERATION**

The fireplace and accompanying components must be installed as an OEM installation in manufactured homes (USA only) or an aftermarket permanently located, or a mobile home, where not prohibited by local codes. The fireplace must be installed in accordance with the Manufacturer's instructions and the Manufactured Home Construction and Safety Standard, Title 24 CFR, Part 3280, in the United States, or the Standard for Installation in Mobile Homes, CAN/CSA Z240 MH Series, in Canada. **Exceeding the restrictions imposed in these instructions may result in a fire or explosion, causing property damage, personal injury, or loss of life. Ortal will not be responsible for any damage caused by improper installation. Do not store or use gasoline or other flammable vapors and liquids near this fireplace.**

### **WARNING: GAS FIREPLACE**

This fireplace is for use only with the type of gas indicated on the rating plate. These fireplaces are not convertible for use with other gases unless a certified kit is used, and the conversion is performed by an authorized and qualified technician. Applicable standards are Vented Gas Fireplace Heaters ANSI Z21.88 / CSA 2.33a and Gas-fired Fireplaces for Use at High Altitudes CAN/CGA 2.17-M91

### **WARNING: CALIFORNIA PROP 65**

These products and the fuels used to operate these products (liquid propane or natural gas), and the products of combustion of such fuels, can expose you to chemicals including benzene, carbon monoxide, and ceramic fibers, which are known to the state of California to cause cancer and/or reproductive harm. For more information, visit [www.p65warnings.ca.gov](http://www.p65warnings.ca.gov).

# Table of Contents

“→” Denotes new or updated information.

<b>General</b>	<b>2</b>
<b>Safety Information and Warnings</b>	<b>2</b>
<b>Product Information</b>	<b>5</b>
Models	5
Certification	5
Rating Label	6
Stand-Offs	7
Fireplace Legs	7
<b>Installation</b>	<b>8</b>
<b>Prior to Installation</b>	<b>8</b>
Locate the Fireplace	8
<b>Fireplace Installation</b>	<b>8</b>
Planning	8
Installation	8
Startup	9
<b>Post-Installation</b>	<b>9</b>
Initial Burning Period	9
Final Inspection Procedure	9
Final Checks and User Instruction	9
<b>Building Around the Fireplace</b>	<b>10</b>
<b>→Building Checklist</b>	<b>10</b>
<b>Framing</b>	<b>11</b>
$\frac{5}{8}$ " Type X Drywall Requirements	11
Chase Floor/Platform	11
Hearth Extension	11
Framing Dimensions	12
General Clearances	16
Heat Release	17
Air Intake	19
Mounting a TV/Artwork	21
Access Panel	22
Chase Area Minimum	22
Recessed Ledge Detail	23
Structural Weight Support	24
<b>Finishing</b>	<b>25</b>
Flush Installation	25
Recessed Installation	26
Maximum Overhang/Mantle Depth	26
<b>Venting</b>	<b>27</b>
<b>General Venting Requirements</b>	<b>27</b>
<b>Vent Configurations</b>	<b>27</b>
Vent Restrictor Sizing Guidelines	29
<b>Clearances</b>	<b>29</b>
<b>Termination</b>	<b>30</b>
Horizontal Termination Clearance Diagram	30
Vertical Termination Clearance Diagram	32
<b>Chimney Shroud</b>	<b>33</b>
<b>Vent Installation</b>	<b>33</b>
<b>Vent Maintenance</b>	<b>34</b>
<b>Co-Axial to Co-Linear Conversion</b>	<b>34</b>
Vent Configuration	35
<b>Gas</b>	<b>35</b>
<b>Gas Pressures</b>	<b>35</b>
<b>Routing the Gas Line</b>	<b>36</b>
Access Panel	36
<b>Gas Conversion</b>	<b>36</b>
<b>High Altitude Requirements</b>	<b>37</b>

→ Gas and Electrical Components	37
<b>Electrical</b>	<b>37</b>
<b>Electrical Requirements</b>	<b>38</b>
Pairing the Remote and Receiver	39
→ <b>Wiring Diagrams</b>	<b>40</b>
Home Automation Wiring Diagram	42
<b>Firelog Setups</b>	<b>43</b>
<b>Firelog Installation Warnings</b>	<b>43</b>
<b>Driftwood Firelogs Set</b>	<b>44</b>
Driftwood Firelog Setup for Traditional 36	45
Driftwood Firelog Setup for Traditional 42	49
<b>Valley Oak Firelog Set</b>	<b>53</b>
Valley Oak Firelog Setup for Traditional 36	54
Valley Oak Firelog Setup for Traditional 42	59
<b>Birch Firelog Set</b>	<b>64</b>
Birch Firelog Setup for Traditional 36	65
Birch Firelog Setup for Traditional 42	69
<b>Log Base/Tube Position Adjustment</b>	<b>73</b>
Adjustment Instructions	73
<b>Operation</b>	<b>77</b>
<b>10-Button Remote Control Handset</b>	<b>77</b>
Operating Instructions	77
<b>Puck Handset</b>	<b>78</b>
Operating Instructions	79
<b>Wall Switch</b>	<b>80</b>
Operating Instructions	80
<b>Fireplace Maintenance</b>	<b>80</b>
<b>General Maintenance</b>	<b>80</b>

## Product Information

### Models

Series	Models	Burner	Certification Standard	Available Gas Types	Direct Venting
Wilderness Traditional	TR 36 TR 42	Driftwood, Valley Oak, or Birch Firelogs	US: ANSI Z21.88 - 2016 Canada: CSA 2.33 - 2016	Natural Gas or Propane	<b>Standard:</b> Type: Direct Vent Size: 5"x8" (co-axial) <b>Optional:</b> Type: Power Vent Vent Size: 3"x5" (co-axial)

#### NOTES:

- For more information on Power Venting, please refer to the Power Vent System Installation and Operation Manual.
- Venting is not supplied by Ortal with the fireplace. The fireplace is certified to be used with (and can be obtained from) the vent manufacturers outlined in "General Venting Requirements" section.

### Certification

Wilderness Traditional series fireplaces have been tested and approved by CSA Group for safety and efficiency for use with Natural Gas (NG) and Propane (LP) only, and **NOT** for use with solid fuels.

CSA Group is approved by the American National Standards Institute (ANSI) as an Accredited Standards Developer.

#### Certification Standard:

**US: ANSI Z21.88 – 2019: Vented Gas Fireplace Heaters**

**Canada: CSA 2.33 – 2019: Vented Gas Fireplace Heaters**



#### Products:

CLASS 2901 84: DOMESTIC HEATERS (GAS) Vented Fireplace: Certified to US Standard

CLASS 2901 04: DOMESTIC HEATERS (GAS) Vented Fireplace

The fireplaces are permitted for indoor use only. "Indoor" is defined as a conditioned space. The fireplaces are not approved for outdoor or partial outdoor installation. The fireplaces must be installed while maintaining required clearances. Installation is recommended in living spaces such as bedrooms, living rooms, great rooms, etc. The fireplaces are not approved for closet installation. The fireplace must be installed according to Ortal requirements in addition to any local codes that may apply, such as USA: ANSI Z223.1/NFPA 54, Canada: CSA B149.

#### IMPORTANT:

- Consult the authority having jurisdiction to determine the need for a permit prior to starting the installation.
- It is the responsibility of the fireplace dealer and installer to ensure that this fireplace is installed and framed in compliance with these instructions and all applicable codes.
- Before starting, take careful note of **ALL** the **WARNINGS** in this manual.

# Rating Label



The fireplace rating label is found on a metal plate separate included with the fireplace.

## DEALERS/INSTALLERS:

You **MUST** leave the fireplace's rating label with the fireplace in an area easily accessible by the owner (typically near the access panel, if available). You must instruct the owner before handing over the fireplace where this label can be found.

## OWNERS:

Make sure the installer leaves your fireplace's rating label in an area that is easily accessible for you. This information is required for servicing and receiving replacement parts.

<b>ORTAL</b> <sup>®</sup>		  	
Manufacturer/Fabricant Ortal Ltd. 14 Haharash St. Hod Hasharon, 4524087 Israel Tel: 011-972-9-7402828 Fax: 011-972-9-7402687		For use only with vent, glass and interior design media certified and approved for use with the appliance. Not for use with solid fuel. For use with barriers certified for this appliance only.  Utilisez uniquement avec des conduits, des panneaux vitrés et des accessoires décoratifs intérieurs homologués et approuvés pour une utilisation avec cet appareil. Pas pour l'usage avec le combustible solide. Pour une utilisation avec des barrières certifiées pour cet appareil uniquement.	
Serial No.:		Approved By: Homologué Par:	CSA No.: 2358468
Tested to: CSA/ANSI Z21.88-2019 • CSA 2.33-2019 for Vented Gas Fireplace Heater Examiné à: CSA/ANSI Z21.88-2019 • CSA 2.33-2019 pour Foyer au gaz à évacuation			
Altitude rating: Estimation d'altitude:	0-2000 ft. / 0-610 m.	Electrical Rating: Estimation Électrique:	120 volt / 60 Hz / less than 5A
<b>Model Series / Modèle Séries: Wilderness Driftwood</b>			
<input type="checkbox"/> Wilderness 44 Front RS/LS/TS <input type="checkbox"/> Wilderness 51 Front RS/LS/TS <input type="checkbox"/> Wilderness 60 Front RS/LS/TS <input type="checkbox"/> Wilderness 44H Front RS/LS/TS <input type="checkbox"/> Wilderness 51H Front RS/LS/TS <input type="checkbox"/> Wilderness 60H Front RS/LS/TS <input type="checkbox"/> Wilderness 44HH Front RS/LS/TS <input type="checkbox"/> Wilderness 51HH Front RS/LS/TS <input type="checkbox"/> Wilderness 60HH Front RS/LS/TS <input type="checkbox"/> Wilderness Traditional 28I <input type="checkbox"/> Wilderness Traditional 36 <input type="checkbox"/> Wilderness Traditional 36S <input type="checkbox"/> Wilderness Traditional 42 <input type="checkbox"/> Wilderness Traditional 51			
Fuel Type/Type de combustible:	<input type="checkbox"/> NG/GN		<input type="checkbox"/> PROPANE
Max Input / Débit max. (BTU/HR):	32,163	31,400	
Min Input / Débit min. (BTU/HR):	15,696	21,400	
Orifice Size / Taille de l'orifice:	320-160-320 380	90-60-90 180	
Gas Inlet Pressure (W.C.) inches: Pression d'entrée de gaz (CE) pouces:	7.0	11.0	
Gas manifold Pressure (W.C.) inches: Pression d'alimentation (CE) pouces:	4.7	4.7	
Clearances to Combustibles (with included standoffs): Espacement par rapport aux matériaux inflammables (avec entretoises inclus):	Sides: Côtés: 0"	Back: Arrière: 0"	In front of Glass Devant le panneau vitré: 16"
Also adhere to clearance diagrams and instructions included in the ORTAL manual. Adhérer également aux schémas d'espacement et des instructions figurant dans le manuel ORTAL.			
SKU: M209-WILD-DRIFT-22			

## Stand-Offs

The fireplace has stand-offs fastened to the body of the fireplace as shown in the figures below. Stand-offs must be fully extended upon installation.

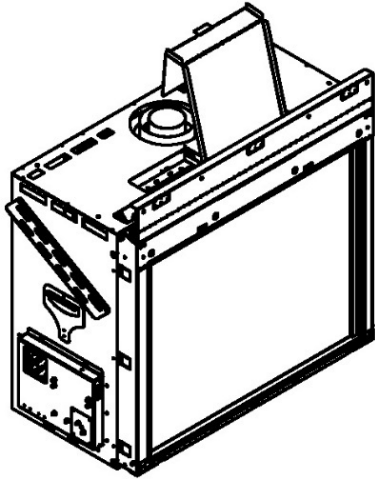

Zero-Clearance Stand-Offs (Isometric View)

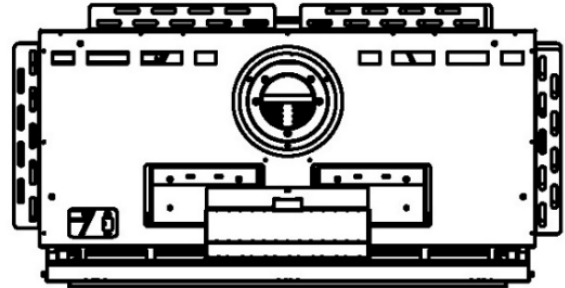

Zero-Clearance Stand-Offs (Top View)

## Fireplace Legs

The Traditional series fireplace legs varies by heat barrier choice.

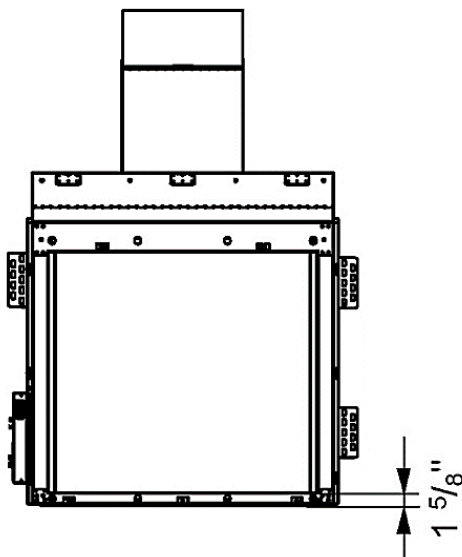

Screen Fireplace

The screen fireplace does not come with legs and can sit directly on the chase floor/platform.

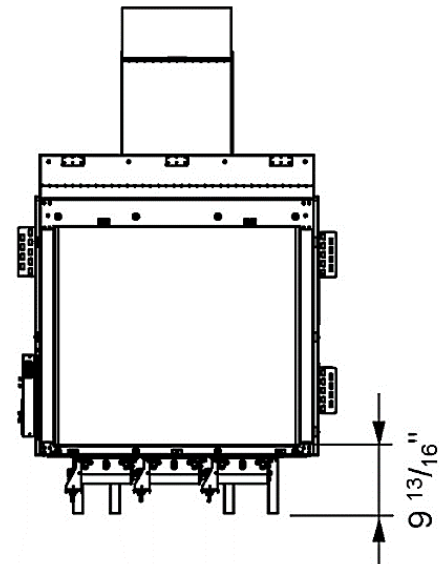

Double Glass Fireplace

The double glass fireplace has legs to allow for space and airflow for the double glass fans. **The legs cannot be cut, removed, or altered in any way.** The legs can sit directly on the chase floor/platform.

**!** NOTE: The surface under the fireplace is not required to be non-combustible. See "Chase Floor/Platform" section for details.

# Installation

## Prior to Installation

### Locate the Fireplace

Keep the following factors in mind when selecting a location for the fireplace:

- Fireplace clearance requirements (review “General Clearances” sections).
- Heat release and air intake requirements (review “Heat Release Requirements” and “Air Intake Requirements” sections).
- Adequate space for servicing.
- Minimum vertical vent rise, allowed horizontal lengths, and degree of offset (review “Venting” section).
- Framing and finishing requirements (review “Framing” and “Finishing” sections).
- Floor or Platform requirements (review “Platform” section).

## Fireplace Installation

Use the following guidelines to ensure a smooth installation. The installation sequence is divided into three phases: Planning, Installation, and Startup.

### Planning

Consult with the contractor and go over all requirements:

- Chase framing requirements.
- 5/8” Type X Drywall (or equivalent) requirements.
- Heat release requirements.
- Air Intake requirements (if applicable).
- Gas and electric specs and location.
- Vent configuration.
- Finishing details.

**NOTE:** Provide the contractor with a copy of the “Building Checklist” and review requirements with them.

### Installation

- Confirm the following items are properly located and built to specification:
  - Framing (with 5/8” Type X Drywall as applicable)
  - Platform
  - Gas and electric
  - Heat release
  - Air intake (if applicable)
- Clear a path free of any possible obstruction to carry in the fireplace.
- Uncrate the fireplace and set in place.
- Make sure all zero-clearance metal stand-offs on the outside of the fireplace are fully extended.
- Secure the fireplace to the framing by attaching the nailing flanges to the framing. See “Securing the Fireplace” section below.
- Remove all zip ties.
- Connect the light grounding cable to the component box that houses the gas and electrical parts.
- Install the vent components. See “Vent Installation” section.
- Review the front wall requirements and finishing details with the contractor.
- Protect the fireplace and components from damage.

### Securing the Fireplace

The fireplace has nailing flanges attached to the face of the fireplace (see figures below). The nailing flanges are to be attached into the framing upon installation. It is crucial to the finishing that the fireplace is stable, level, and plumb. For added stability (though not required), re-use the shipping brackets to secure the legs of the fireplace to floor/platform.

### Vent Installation

Venting must be installed according to the requirements detailed in the “Venting” section of this manual in conjunction with the vent system manufacturer’s installation instructions. Venting must be supported by the structural surrounding and not by the fireplace. Each offset (elbow) must be strapped to reduce movement or possible disconnection.

The first section of venting must be secured to the fireplace starter collar with a minimum of 3 sheet metal screws no longer than 1/2”. DO NOT use silicone to seal the sections. If sealing is required by the vent manufacturer or local code, use Mil-Pac sealant.

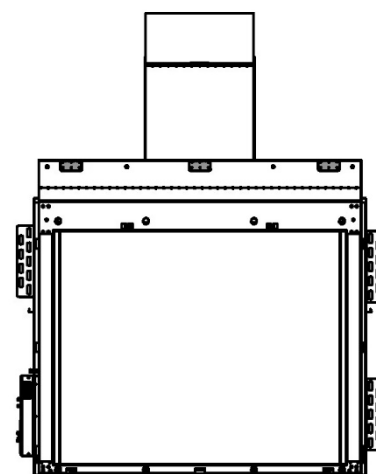

Nailing Flanges

## Startup

---

- Perform a visual inspection to confirm that all work was completed correctly and per specification.
- Confirm that gas and electricity are properly connected and live.
- Remove the safety barrier and glass and clean the inside of the fireplace.
- Install the Driftwood Firelogs on the burner as specified in “Log Placement” section.
- Confirm the log placement is set up per specification.
- Confirm the fireplace is operating properly.
- Check remote-control setup.
- Remove protective layer from glass.
- Clean glass.
- Reinstall the glass and safety barrier.
- Review operation of the fireplace and remote control with the owner.
- Set up return visit to clean glass after the Initial Burning Period (see “Post Installation” section below).

## Post-Installation

---

Complete the following post-installation steps..

### Initial Burning Period

---

There is a 12-hour minimum burning period following installation of the fireplace. This 12-hour period must include a minimum of 4 consecutive hours of continuous burning. During this time, the owner or installer may notice:

- The glass developing a white or “cloudy” film
- An unusual smell

Both the film and the smell are due to the paint on the fireplace metal heating and “burning off”. This is normal. The cloudiness and odor will disappear after the 12-hour period elapses and the installer returns to service the fireplace and complete startup.

### Final Inspection Procedure

---

When the 12-hour burning period is complete, the installer must return and perform the final inspection, which includes:

- Cleaning the glass with a ceramic glass cleaner (otherwise the white film will remain)
- Checking the interior media setup
- Checking for gas leaks
- Adjusting the restrictor (if necessary)
- Performing an overall check to make sure that everything is working properly

When these activities are complete, initial startup is concluded and the fireplace may be operated by the owner.

### Final Checks and User Instruction

---

Before releasing the fireplace to the customer for use without installer supervision, the installer must ensure that the fireplace is burning correctly. In addition, the installer must review and explain the following to the owner:

- Safety warnings
- Fireplace operation
- Warranty requirements
- Maintenance requirements
- Glass is hot during and after operation
- If any questions or concerns arise, owner must contact the local Ortal dealer/installer for support.

# Building Around the Fireplace

## → Building Checklist

The following building checklist is a quick reference for a typical Ortal Wilderness Traditional Series installation. This list is not exhaustive and does not supplement thorough review of the installation manual.

- ☑ **Fireplace Location:** Ensure the location allows for min. 16" clearance from viewing area to furniture and other combustibles. Make sure a clear path is established to allow the fireplace to be safely transported to installation location.
- ☑ **Venting:** Confirm vent size (5"x8"), vent clearance (1" on sides and bottom, 3" on top), vent configuration, and termination location.
- ☑ **Height from Floor:** For double glass fireplaces, leg height is 9 <sup>13</sup>/<sub>16</sub>" (to bottom viewing area). Legs cannot be removed/altered. If desired viewing area location on the wall is higher than 9 <sup>13</sup>/<sub>16</sub>", a platform can be built for the fireplace to stand on. Screen fireplaces have no legs, allowing the firebox to sit directly on the floor. The distance between the bottom of the firebox and the bottom of the viewing area is 1 <sup>5</sup>/<sub>8</sub>". If desired viewing area location on the wall is higher than 1 <sup>5</sup>/<sub>8</sub>", a platform can be built for the fireplace to stand on.
- ☑ **Chase Floor/Platform:** Both screen and double glass fireplaces can stand on the chase floor or a platform. Floor or platform must be able to bear the weight of the fireplace. It can be constructed out of wood, concrete, metal, or any other solid materials (not required to be non-combustible).
- ☑ **Chase Construction:** No materials can be attached directly to the fireplace (exception: <sup>5</sup>/<sub>8</sub>" Type X Drywall). Drywall may be fastened to front zero-clearance stand-off only. Chase interior must be large enough to accommodate fireplace with all metal stand-offs fully extended. The area of the chase interior must be min. 120 square inches at any given point within the chase.
- ☑ → **Framing:** Adhere to minimum framing dimensions (or greater). *When constructing the framing for the fireplace, please add up to +.25" variance to each side, and the top, of the fireplace frame. This added variance will allow added space to maneuver and adjust the fireplace when setting it in the chase.* The first 10 <sup>7</sup>/<sub>16</sub>" above the top of the fireplace viewing area must always be non-combustible framing. For recessed fireplaces, do not exceed 12" max. front overhang depth limit.. No material is permitted to extend past the metal lip surrounding the fireplace viewing area.
- ☑ **<sup>5</sup>/<sub>8</sub>" Type X Drywall Requirements:** One layer of <sup>5</sup>/<sub>8</sub>" Type X Drywall (or equivalent) must be installed on the exterior of the chase framing. <sup>5</sup>/<sub>8</sub>" Type X Drywall (or equivalent) may be fastened to the *front zero-clearance stand-off only*, with 1" self-tapping drywall screws 16".
- ☑ **TV/Artwork:** TV/Art must be min. 4" above top of fireplace viewing area.
- ☑ **Gas Supply Line and Power Location:** Gas and electrical components are located in the compartment on the left side of the fireplace. A single gang 120V outlet is provided in this compartment. Route gas line and electrical connections to this compartment. Locate gas line with manual shut off according to local code.
- ☑ **Access Panel:** Not required. Gas and electrical components are only accessible through the built-in access panel inside the firebox on the left wall. Exception: An access panel or some other form of clear access to the chase is only required if the fireplace is power-vented.
- ☑ **Heat Release:** *Crucial for Cool Wall Technology.* Must start within 6" (max.) from the chase's ceiling. Min. heat release size is 120 sq.in. of net free air space. Height of the heat release must not exceed 1/3 of the width.
- ☑ **Air Intake:** Only required for double glass heat barrier. Must be located at or below the level of double glass fans. Min. 124 sq.in. of net free air space.
- ☑ **Finishing:** For finishes flush to the fireplace, no clearances are required. For finishes where the fireplace is recessed to the finish, maintain <sup>1</sup>/<sub>8</sub>" from the finish to the front face of the fireplace.

## Framing

Fireplace chase may be framed with either combustible (typically wood studs) or non-combustible framing (typically metal studs). Any framing within  $10\frac{7}{16}$ " from the top of the fireplace glass (viewing area) must be non-combustible. Any framing after that point may be combustible.

The framing of the fireplace chase must be designed to carry the entire weight of the wall and finish material. Surrounding material must not transfer weight to the fireplace or be connected in any way to the fireplace, with the exception of  $\frac{5}{8}$ " Type X drywall or its equivalent.  **$\frac{5}{8}$ " Type X drywall may be fastened to the top framing stand-offs only, with 1-inch self-tapping drywall screws.**

No material is permitted to extend past the metal drywall lip surrounding the fireplace viewing area. This area must be unobstructed to allow the heat barrier and inside glass panel to be removable.

## $\frac{5}{8}$ " Type X Drywall Requirements

Exterior of framing must be covered with  $\frac{5}{8}$ " Type X Drywall (or equivalent). Chase interior does not require a layer of  $\frac{5}{8}$ " Type X Drywall (or equivalent). This applies to both combustible and non-combustible framing.

**NOTE:**  $\frac{5}{8}$ " Type X Drywall is not required on the exterior portion of an insulated outside-facing wall.

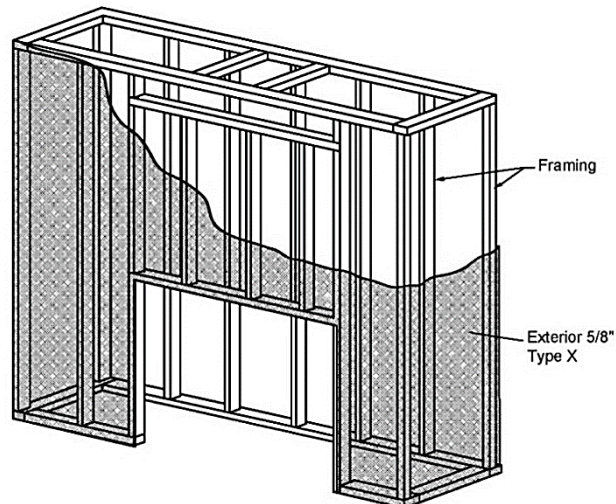

## Chase Floor/Platform

The fireplace must be installed on a flat, solid, continuous surface. Surface can be wood, concrete, metal, and other typical solid floor types. Surface material is not required to be non-combustible.

The distance from the bottom of the fireplace opening to the floor varies depending on heat barrier (see figures below).

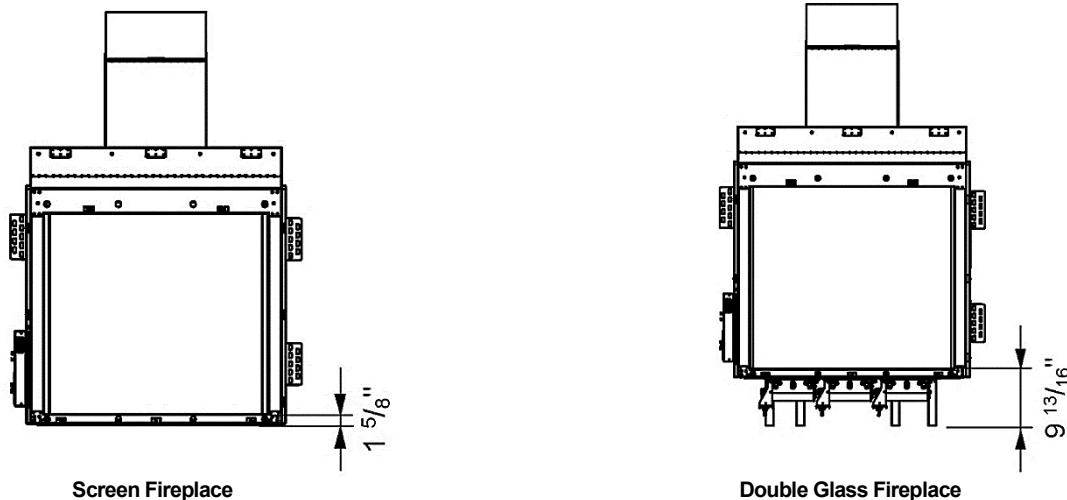

**Raised Platform Option:** To raise the fireplace higher than  $1\frac{5}{8}$ " for screen or  $9\frac{13}{16}$ " for double glass, build a platform for the fireplace to stand on. Platform must be stable and able to bear the full weight of the fireplace. A platform can be constructed out of wood, concrete, metal, or any other solid materials. Platform material is not required to be non-combustible.

**NOTE:** For fireplaces with the double glass heat barrier, an air intake might be necessary to incorporate into the platform depending on the design. See "Air Intake for a Platform" for details.

## Hearth Extension

A hearth extension is not required. Any hearth extension used is for appearance only and does not have to conform to a standard hearth extension installation requirement.

# Framing Dimensions

The following diagrams are for illustrative purposes only. There are multiple approved installation scenarios. A flush application is not the only permitted application. The fireplace may be recessed into the wall. Refer to diagrams and values below and in the following pages for details. **Framing dimensions are the same for combustible and non-combustible framing.**

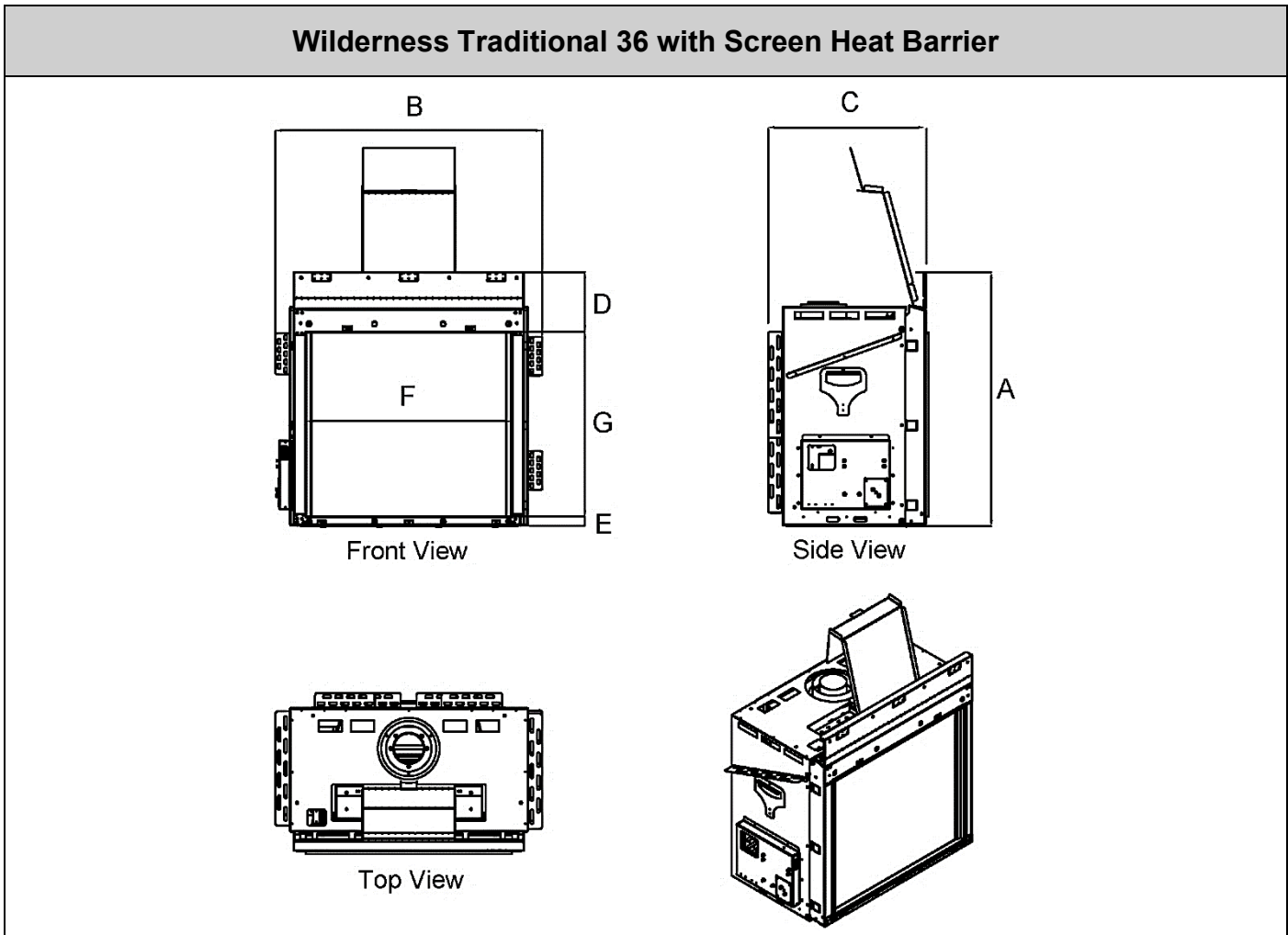

A: Height	B: Length	C: Depth	D: Stand-Off	E: Bottom	F: Glass Length	G: Glass Height
43 5/8"	45 13/16"	27 1/16"	10 7/16"	1 5/8"	35 7/16"	31 5/8"

No material is permitted to extend past the 5/8" metal drywall lip surrounding the fireplace viewing area. This area must be unobstructed to allow the heat barrier and inside glass panel to be removable.

Framing	
A: Height	43 5/8"
B: Length	45 13/16"
C: Depth	27 1/16"
V: Firestop	Refer to pipe manufacturer's firestop dimensions

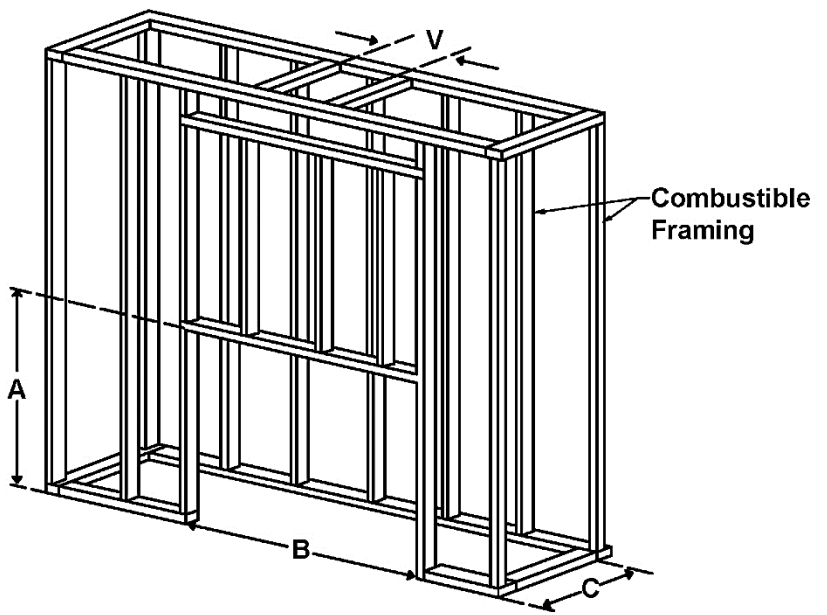

## Wilderness Traditional 36 with Double Glass Heat Barrier

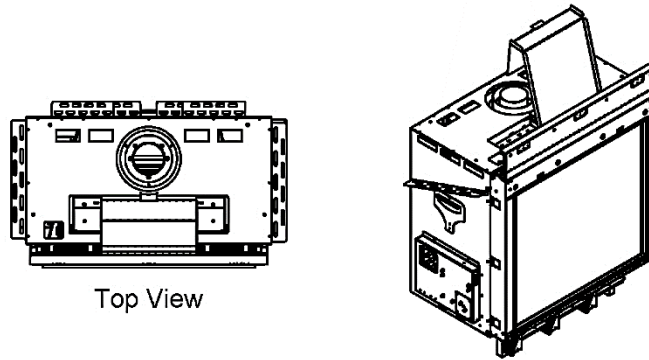
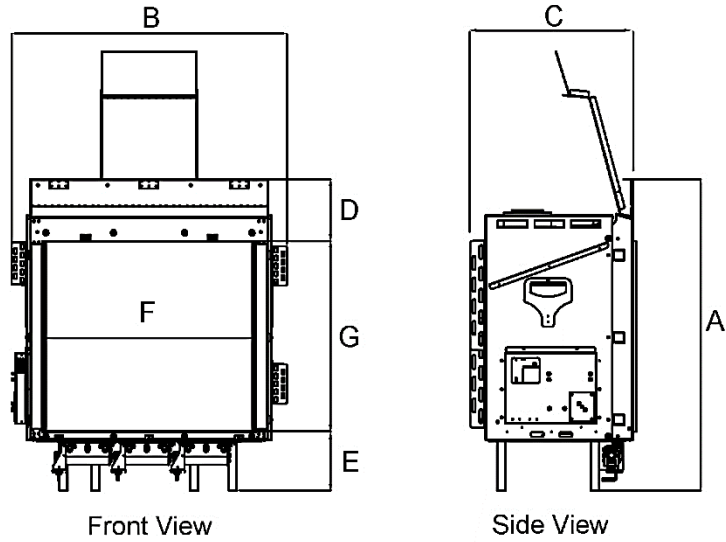

A: Height	B: Length	C: Depth	D: Stand-Off	E: Legs	F: Glass Length	G: Glass Height
51 3/4"	45 13/16"	27 1/16"	10 7/16"	9 13/16"	35 7/16"	31 5/8"

No material is permitted to extend past the 5/8" deep metal drywall lip surrounding the fireplace viewing area. This area must be unobstructed to allow the heat barrier and inside glass panel to be removable.

Framing	
A: Height	51 3/4"
B: Length	45 13/16"
C: Depth	27 1/16"
V: Firestop	Refer to pipe manufacturer's firestop dimensions

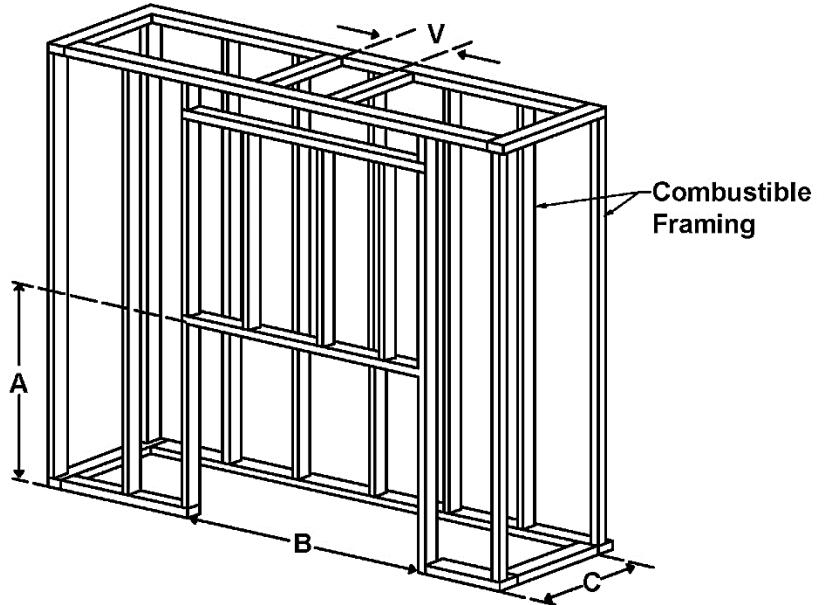

## Wilderness Traditional 42 with Screen Heat Barrier

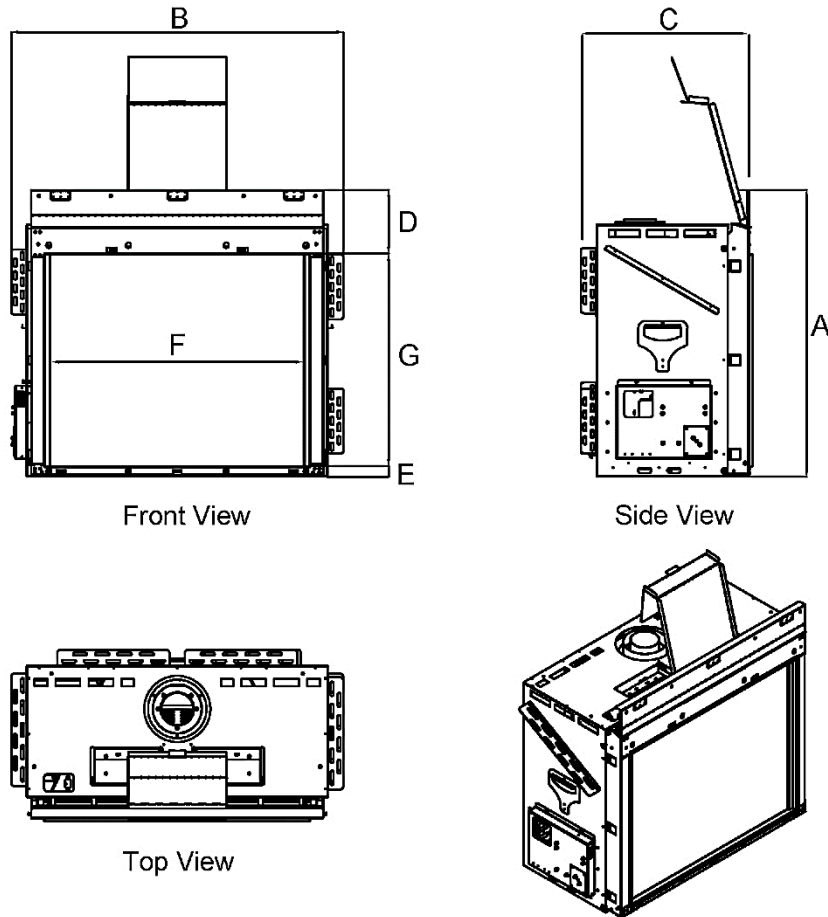

A: Height	B: Length	C: Depth	D: Stand-Off	E: Bottom	F: Glass Length	G: Glass Height
46 1/8"	53 5/16"	27 1/16"	10 7/16"	1 5/8"	42 11/16"	34 1/8"

No material is permitted to extend past the 5/8" deep metal drywall lip surrounding the fireplace viewing area. This area must be unobstructed to allow the heat barrier and inside glass panel to be removable.

Framing	
A: Height	46 1/8"
B: Length	53 5/16"
C: Depth	27 1/16"
V: Firestop	Refer to pipe manufacturer's firestop dimensions

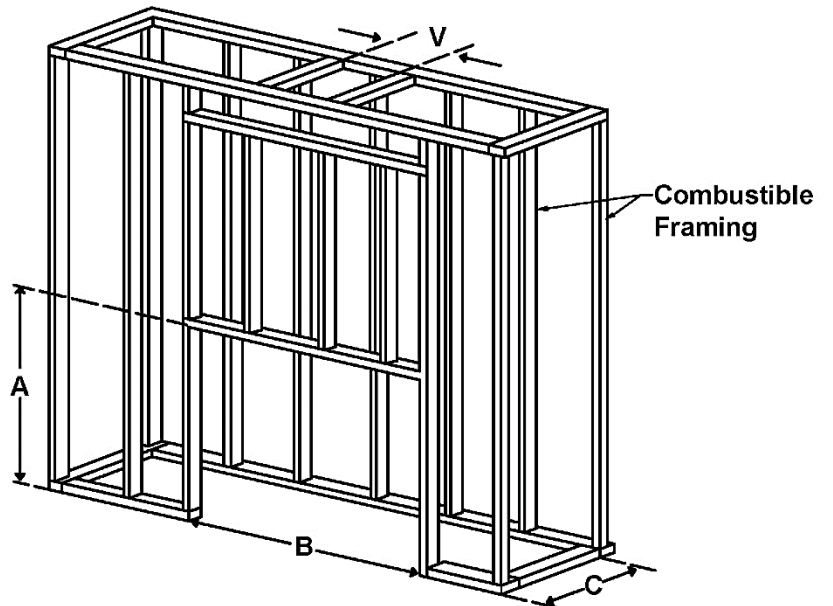

## Wilderness Traditional 42 with Double Glass Heat Barrier

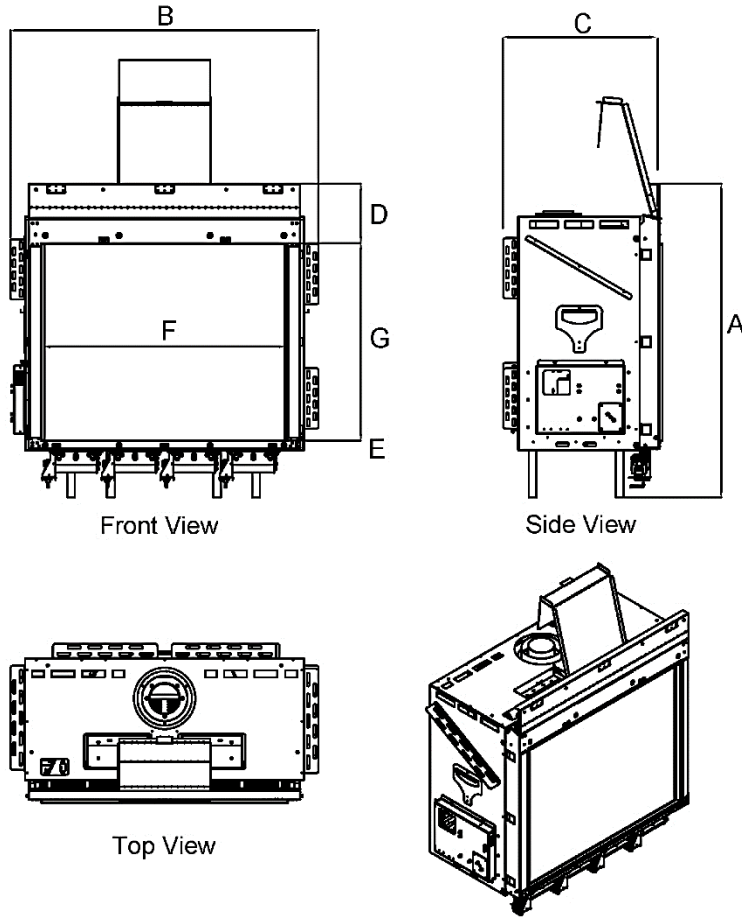

A: Height	B: Length	C: Depth	D: Stand-Off	E: Legs	F: Glass Length	G: Glass Height
54 1/4"	53 5/16"	27 1/16"	10 7/16"	9 13/16"	42 11/16"	34 1/8"

No material is permitted to extend past the 5/8" deep metal drywall lip surrounding the fireplace viewing area. This area must be unobstructed to allow the heat barrier and inside glass panel to be removable.

Framing	
A: Height	54 1/4"
B: Length	53 5/16"
C: Depth	27 1/16"
V: Firestop	Refer to pipe manufacturer's firestop dimensions

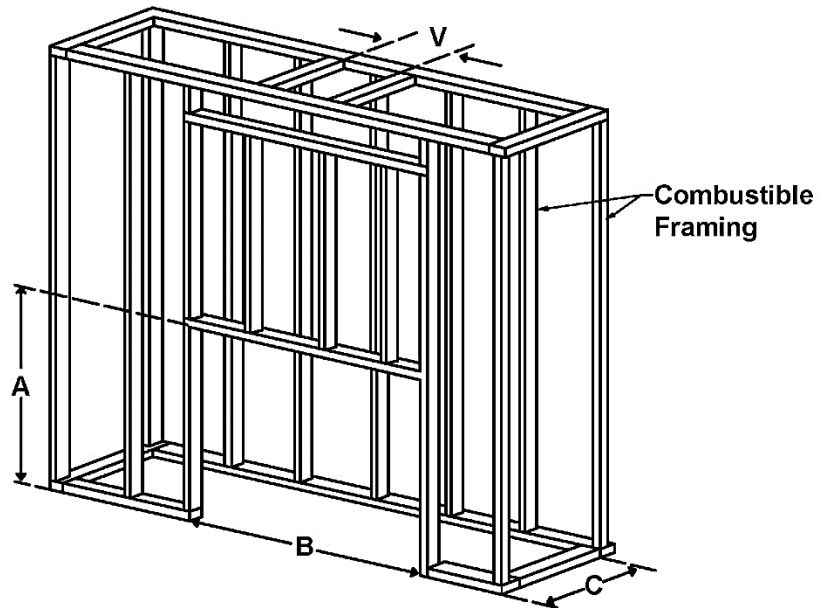

## General Clearances

### Viewing Area Clearance Zone

The viewing area clearance zone is an area that extends perpendicular from the fireplace viewing area. The depth of the viewing area clearance zone depends on the combustibility of the material in question. Distance is measured from the fireplace heat barrier.

<b>Non-Combustible Materials</b>	Must be a minimum of <b>12 inches</b> from the fireplace viewing area.
<b>Combustible Materials</b>	Must be a minimum of <b>16 inches</b> from the fireplace viewing area.

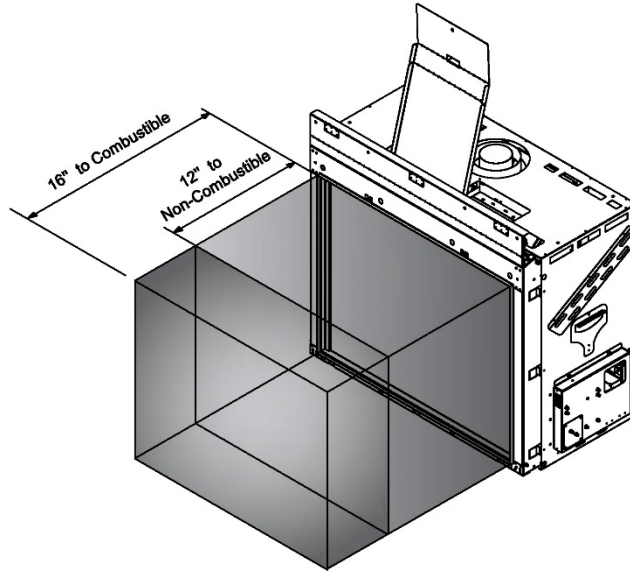

Materials (including combustible flooring and combustible finish material) are permitted below and around the viewing area clearance zone.

**! IMPORTANT NOTE:** When placing material near the glass, take care to consider fireplace serviceability. It is strongly recommended that any items/materials placed in front of the front (long) glass be movable for easy access to the fireplace during servicing.

### Clearance to a Side Wall/Mantle Legs

The fireplace viewing area is zero-clearance to a side wall or mantle legs. A side wall is defined as a wall that meets the viewing area at a 90° angle.

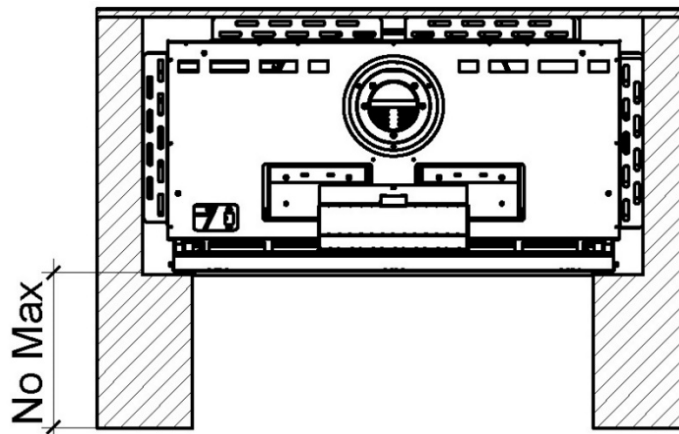

 = Building Material

The temperature on the side wall can get as high as 150°F above ambient temperature. While the fireplace certification allows for this temperature variance, building and finish materials will have their own limitations. Consult the material manufacturer to ensure the material can safely withstand this temperature range.

This information does not apply to a wall that is constructed in front of the viewing area. For materials that will be in front of a main or side viewing area, please refer to the “Viewing Area Clearances” section.

# Heat Release

A heat release is an opening in the fireplace chase that allows the heat inside the chase to passively circulate into an interior room. This heat is generated convectively as the fireplace heats up. It is separate from exhaust heat produced at the combustion chamber of the fireplace. **A heat release is required** to keep the wall around the fireplace cool.

## Heat Release Requirements

- The heat release must be located at or near the top of the fireplace chase and **start within 6 inches (0-6 inches max)** of the chase ceiling (draft stop). It can start at the chase ceiling. It can be located on the front, sides or back of the chase. It can be released into any interior space that shares a wall with the chase.
- The heat release cannot be vented outdoors as this would expose the fireplace to outdoor elements.
- Minimum heat release size requirement depends on heat release orientation:

Horizontal Heat Release	Vertical Heat Release
Minimum 120 sq. in. of net free air space	Minimum 156 sq. in. of net free air space

- For horizontal heat releases, the height of the heat release must not exceed 1/3 of the width. The heat release must be 2/3 wider than it is tall or else it will be considered a vertical heat release and require a larger free air space.
- The heat release can be in the form of (but not limited to) a louvered ventilation grille, gap, or reveal.
- For louvered ventilation grilles, the net free air space allowed in the louvered area must be equal or greater than the minimum number of square inches required per fireplace.
- The interior area of the narrowest part of the fireplace chase (in square inches) must never be less than your required heat release size (see "Chase Area Minimum" section for details).

The following diagrams are examples of potential heat release options. These drawings serve as illustrative purposes only.

### Horizontal Heat Release

Note: The chase ceiling and the room ceiling are different reference points. The chase ceiling may be lower than, equal to, or higher than the room ceiling. The heat release must start within 6" of the chase ceiling. It cannot start lower than 6" from the chase ceiling.

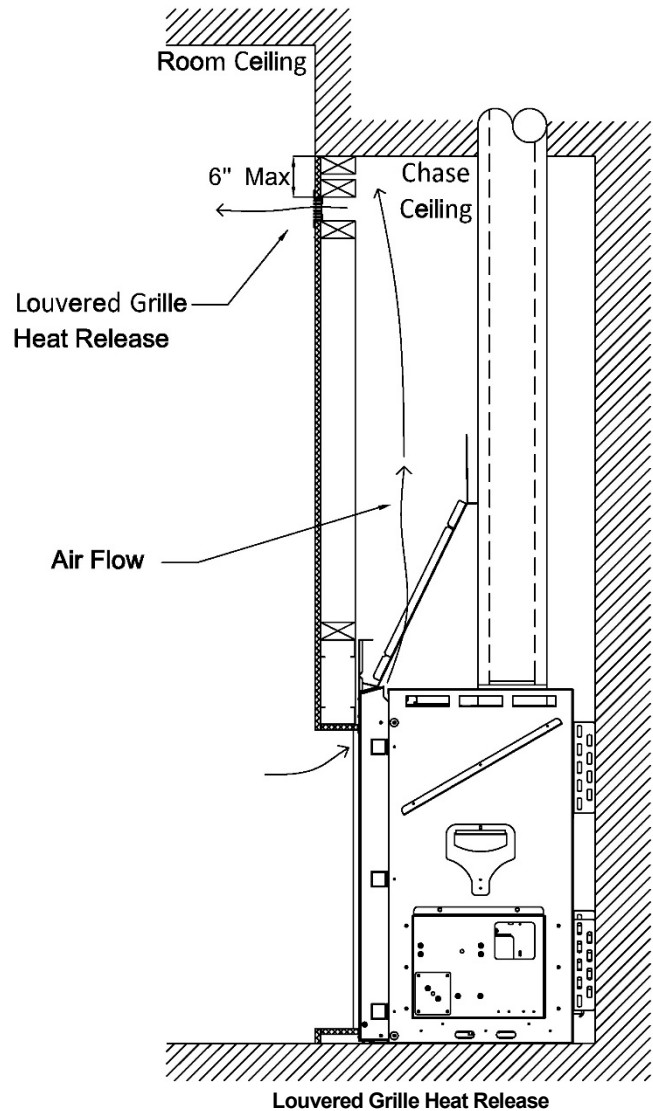
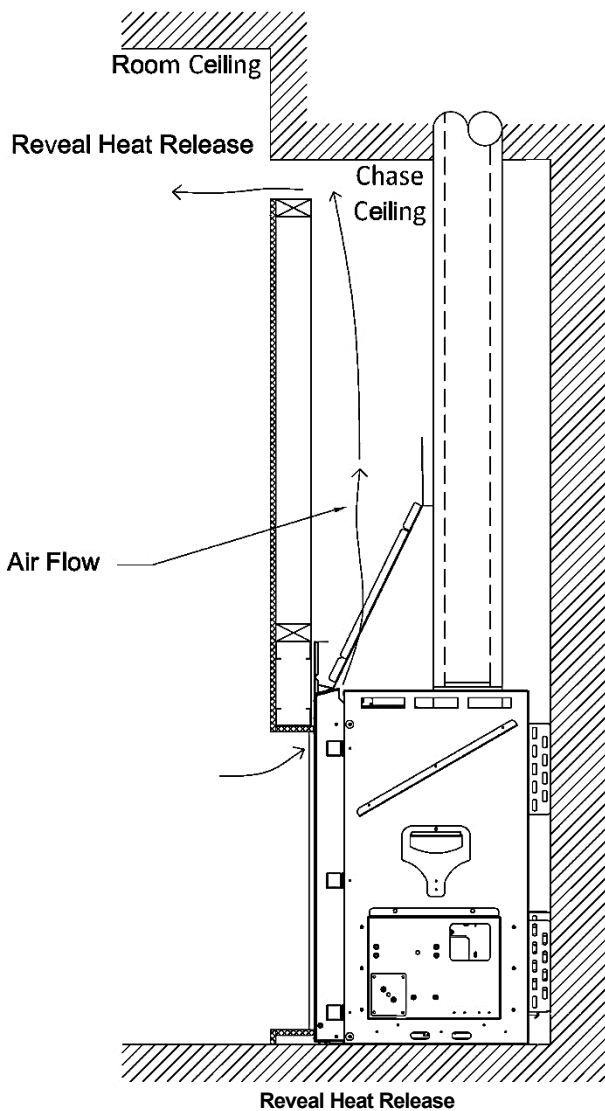

**Vertical Heat Release: Split Front**

The heat release is oriented vertically and split between the two sides of the chase.

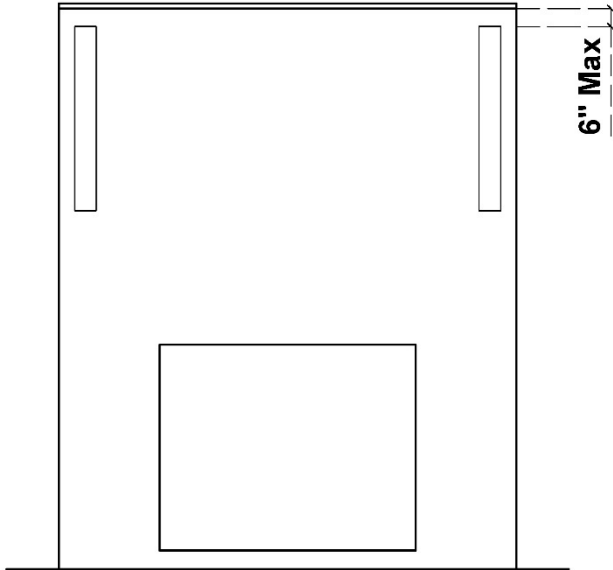

Split Front Vertical Heat Release

**Vertical Heat Release: Full Side**

The heat release is oriented vertically. Entire heat release is on one side of the fireplace chase.

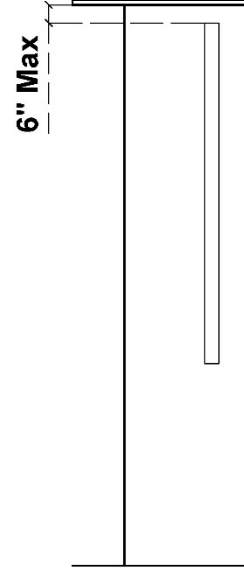

Full Vertical Heat Release on One Side

**Sprinkler Clearance to Heat Release**

In a situation where a sprinkler head is near the heat release, the sprinkler head must be minimum **24 inches** (linear length) from the heat release opening.

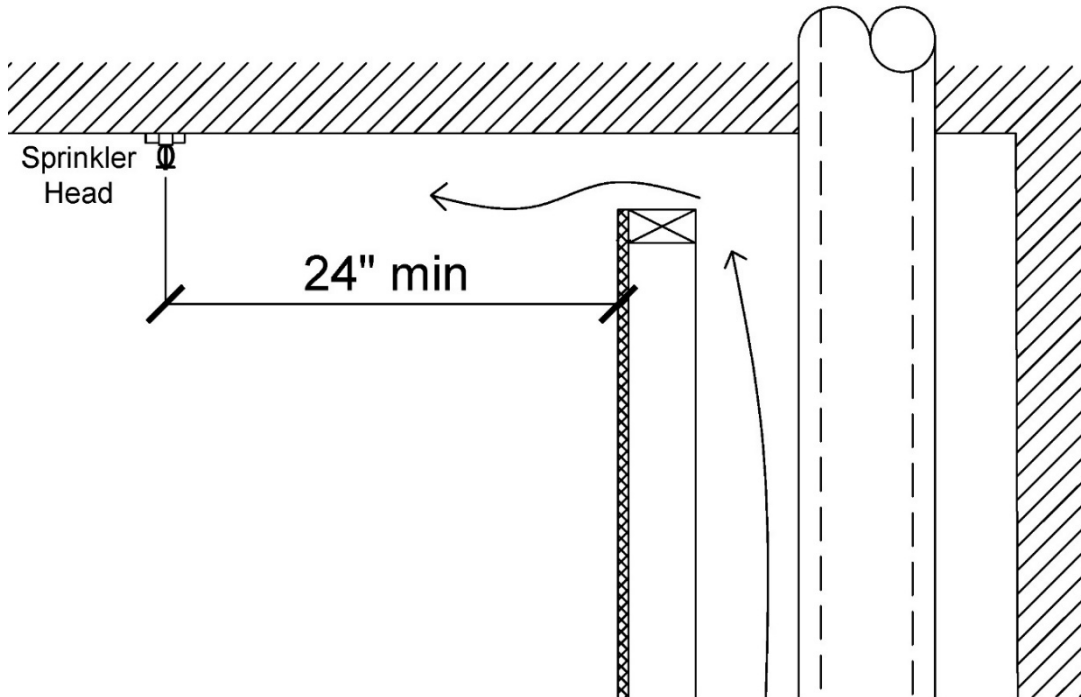

## Air Intake

An air intake is necessary for double glass fireplaces only. Screen heat barriers do not require air intake.

When installing a fireplace with a double glass heat barrier, it is essential to maintain cool air flow between the double glass panels. For this purpose, an opening must be provided toward the bottom of the wall to allow the double glass fans to circulate room air through the glass panels and up into the chase. This opening, called an air intake, needs to be made before closing the wall surface below the fireplace. Air intake must meet the minimum size requirement.

Air Intake
Minimum 124 sq. in. of net free air space

The air intake can be in the form of a louvered ventilation grille, gap, or toe-kick (reveal). For louvered ventilation grilles, the net free air space allowed in the louvered area must be equal or greater than the minimum number of square inches required per fireplace.

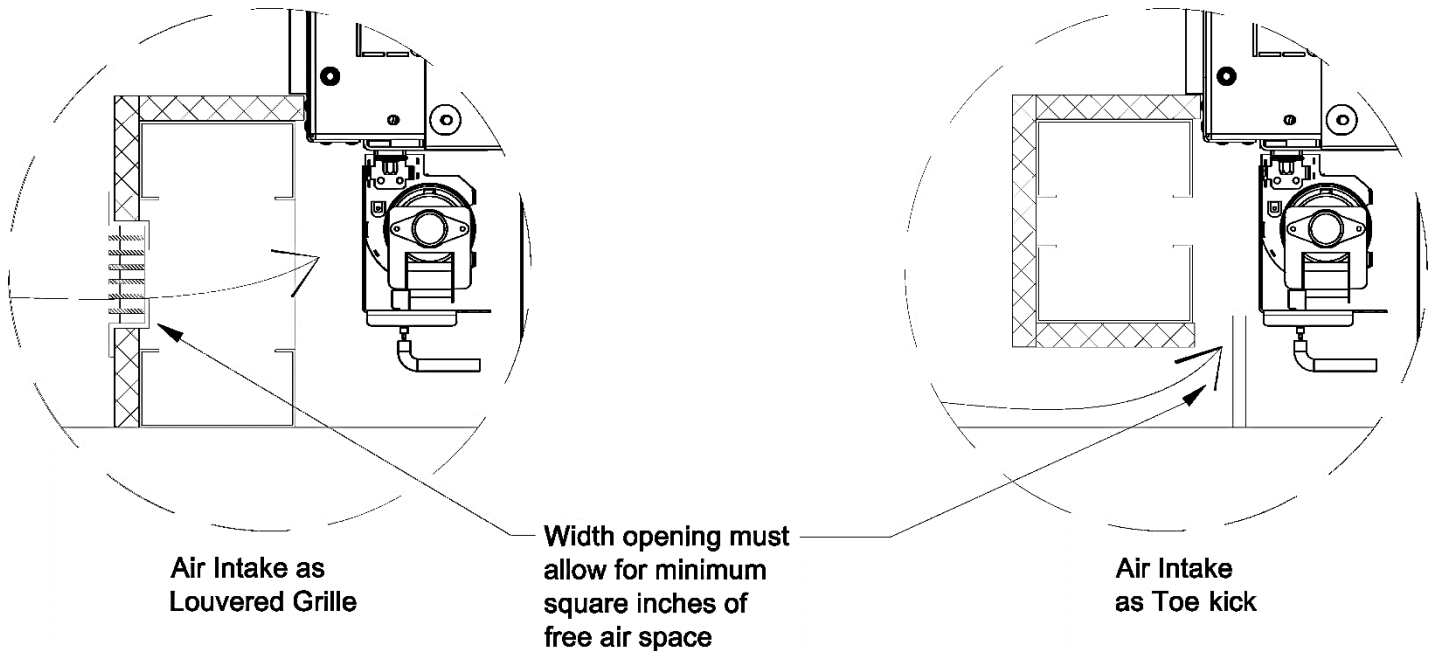

**The entire air intake must be located at or below the double glass fans.** The air intake is not required to be on the front wall of the fireplace. The air intake cannot be on a wall that allows air from outside the house directly into the fireplace chase.

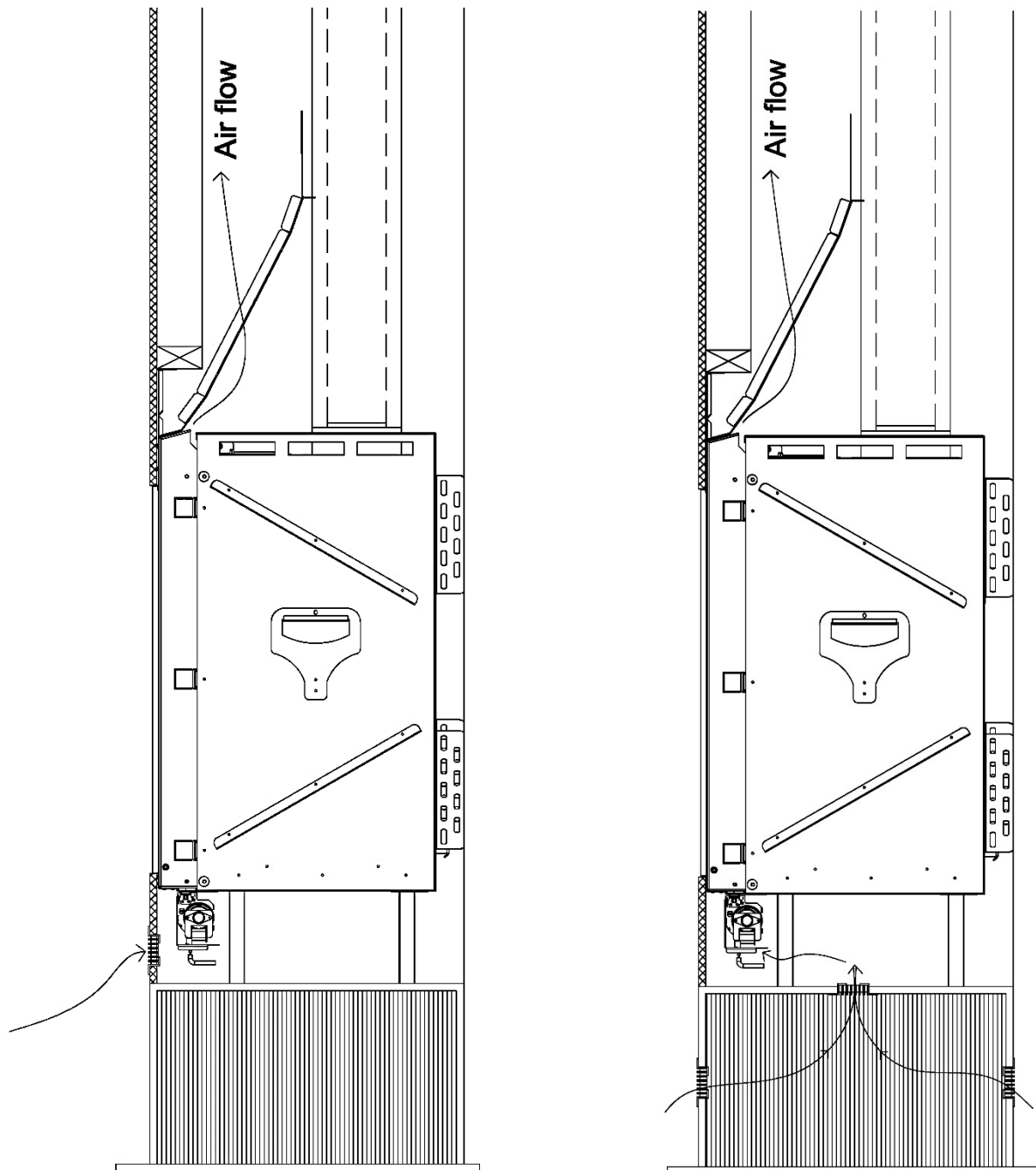

## Air Intake for a Platform



**LEGEND**

	5/8" Type X Drywall
	Combustible Framing

 **NOTE:** Please refer to the “Platform” section for details on platform construction.

## Mounting a TV/Artwork

Ortal's Cool Wall Technology is engineering that reduces the convective heat from the fireplace and prevents heat buildup inside the fireplace chase, mitigating any damage that may result from the wall reaching high temperatures. Ortal's Cool Wall system provides the option of safely installing artwork, a TV, or other similar electronic components above the fireplace by reducing the wall temperature above the fireplace.

Location	Wall Temperature
0-6 inches above fireplace	100°F - 120°F
6-12 inches above fireplace	90°F - 100°F
12 inches above fireplace	80°F - 90°F

Required minimum clearance between bottom edge of TV or other similar device or artwork and top of fireplace viewing area is 12 inches.

### Maintain the following general requirements to mount a TV or artwork above the fireplace and prevent heat damage:

- Mount the TV or artwork at the minimum clearance above the top of the fireplace viewing area. Minimum clearance amount depends on flush or recessed installation. See sections below for more information.
- Wires inside the chase are not permitted to cross over the fireplace. Wires must be installed against a wall.

The decision to install a television above an Ortal fireplace is up to the discretion of the owner. TV and art manufacturers may specify that their product should not be installed on, near or above a heat source. Ortal will not be held liable for any adverse effects on a TV, artwork or other equipment located near the Ortal fireplace. It is the owner's responsibility to verify that their TV or artwork can withstand the wall temperatures as outlined in the above wall temperature chart.

The following diagrams can be used as a guide for customers who do decide to locate their TV and artwork above their Ortal fireplace. These drawings illustrate ways of reducing the amount of heat impact to the area surrounding the fireplace.

### Flush Mounted TV/Artwork

When the TV is mounted on a wall that is flush to the fireplace, the TV must be at least **4 inches** from the top of the fireplace glass viewing area. Ensure all clearances are maintained. See diagram below for details.

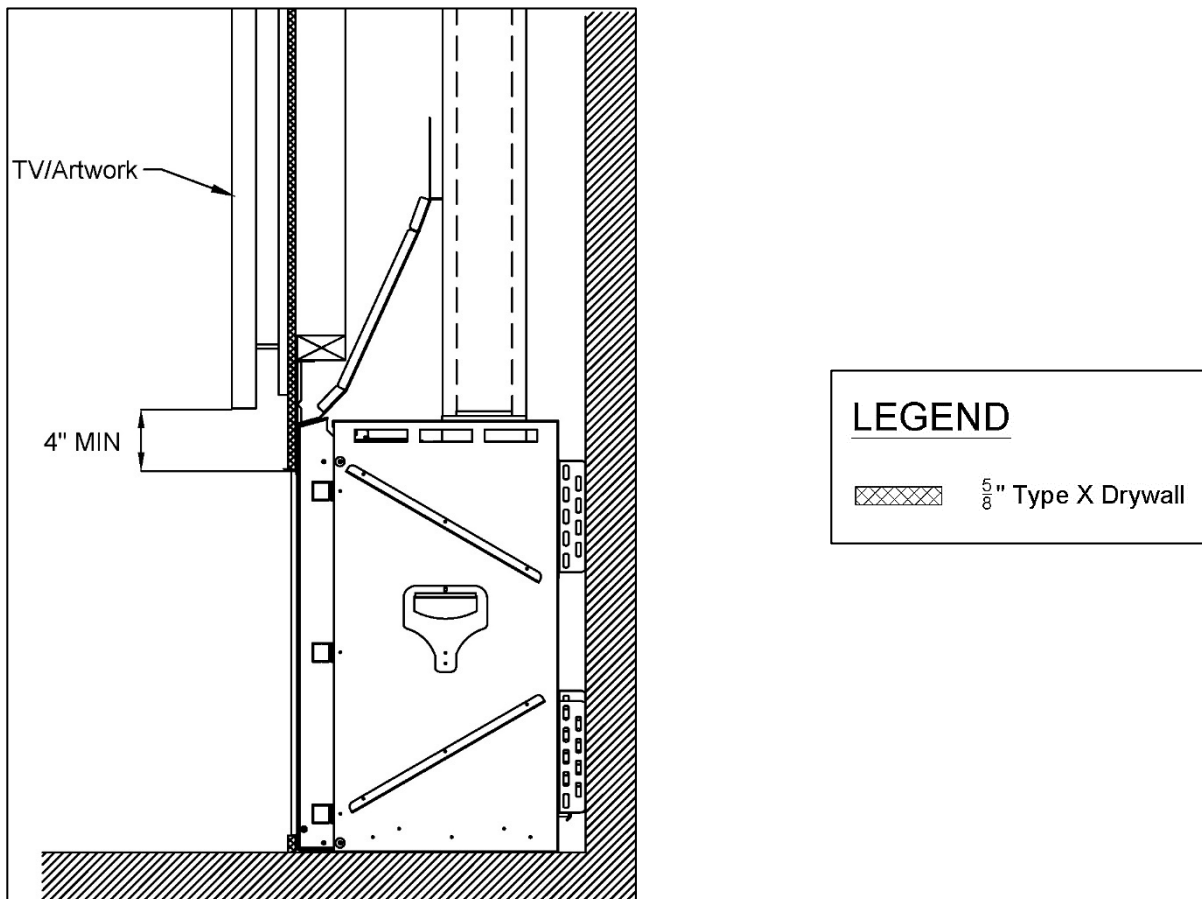

## Recessed TV/Artwork

When the TV is mounted on a wall that recesses over the fireplace, the TV must be at least **12 inches** from the top of the fireplace glass viewing area.

At 12 inches above the fireplace viewing area, maximum possible recess is 4 inches. A deeper recess will interfere with required clearances to venting. Maximum possible recess increases at greater than 12" above the viewing area when venting is offset (as shown in diagram below).

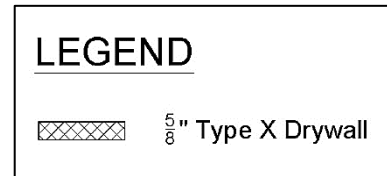
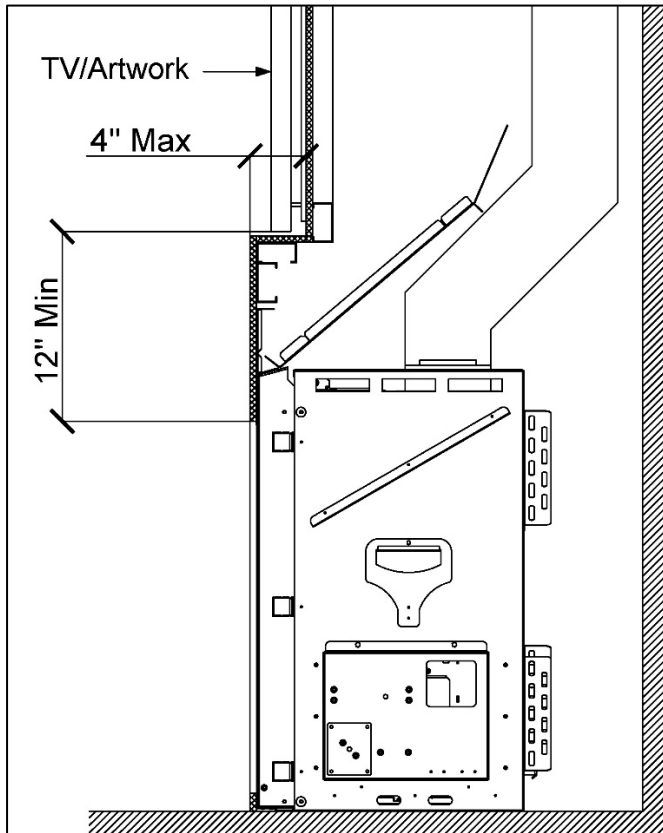

## Access Panel

It is unnecessary to provide an access panel in the fireplace chase (see note below for exception).

Components are accessed through the fireplace via a built-in access panel on the inner left side of the fireplace.

**NOTE:** An access panel, or some other form of clear access, is required for power vented fireplaces. For servicing purposes, the power vent control box (located at the fireplace) must be easily accessible in a way that does not require removal of the fireplace glass.

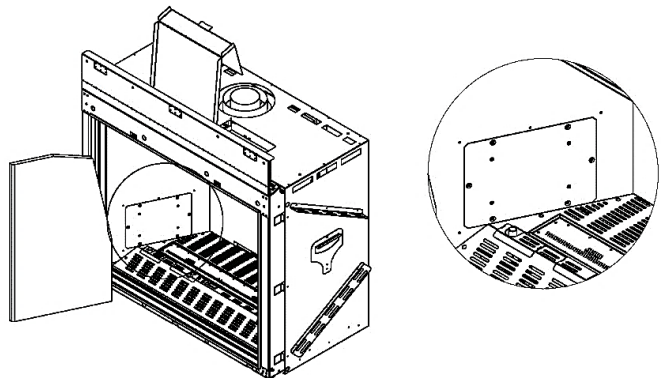

Built-in Access Panel

## Chase Area Minimum

To ensure the convective heat within the chase passively moves to the heat release at an optimal rate, all parts of the interior of the chase must be a **minimum of 120 sq. in.** in size at any given point. To determine if your chase meets this requirement, use the following equation at the narrowest part of the chase.

$$\text{Chase Area} = (\text{Chase Length} \times \text{Chase Depth}) - (50.27\text{in}^2)$$

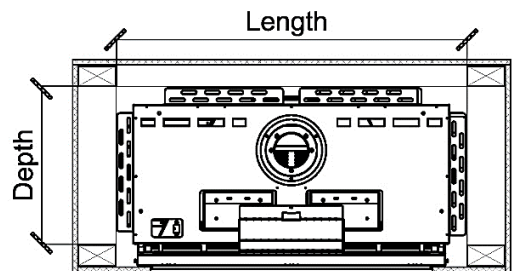

Fireplace Chase (Top View)

If the heat release is split into 25/75 portions due to an oversized ledge, the chase only needs to be the size of 75% of the heat release because 25% of the heat is already being released at the ledge (see "Ledge Detail" section below for details).

## Recessed Ledge Detail

A ledge over the top of a fireplace that is less than 24 inches from the top of the fireplace viewing area must maintain a minimum of **12 inches from the top of the viewing area to the bottom of the building material. Entire structure must be non-combustible (framing and finish).**

If ledge surface area exceeds **220 sq.in.**, the heat release must be divided up between the ledge and the chase ceiling: 25% at the ledge and 75% at the chase ceiling.

**Ledge Size:  $A \times B \leq 220 \text{ sq. in.}$**

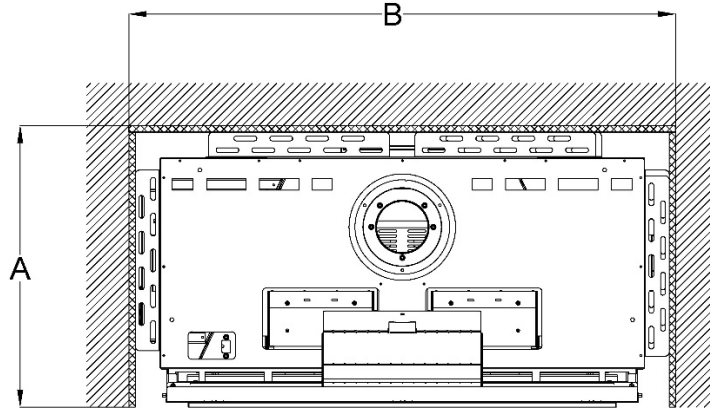

A = ledge depth, B= ledge length (Top View)

## Oversized Ledge

If ledge surface area exceeds the values shown in the chart above, the heat release must be divided between the ledge and the chase ceiling.

**NOTE:** Chase area minimum requirements must be met throughout the entire fireplace chase. See "Chase Area Minimum" section.

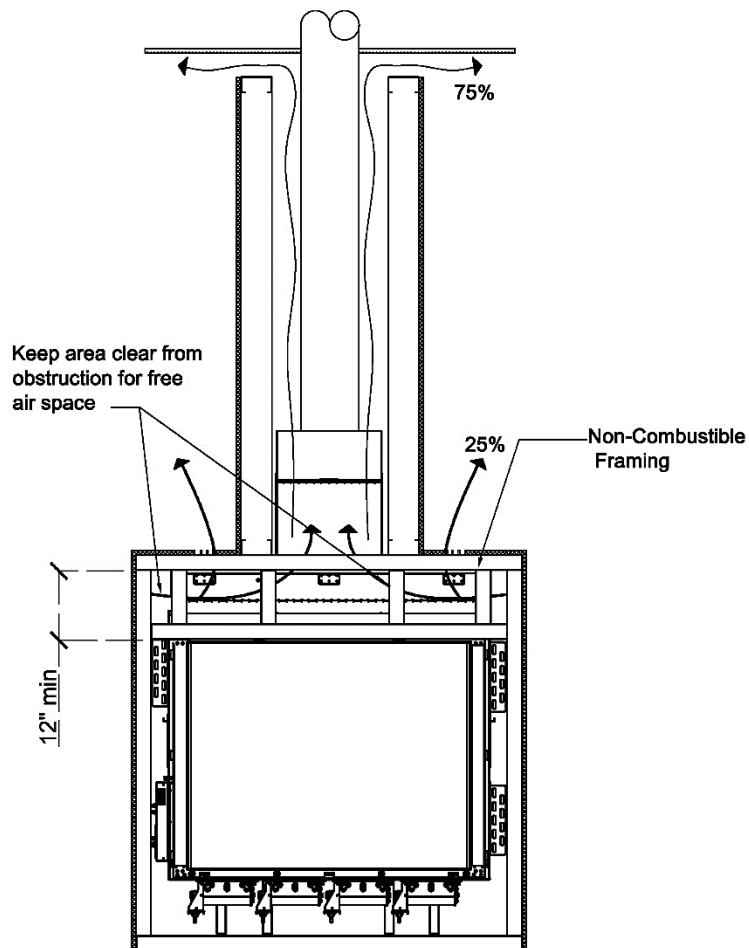

Oversized Ledge Detail

## Structural Weight Support

The fireplace must not carry any structural weight. The framing must be supported by another surface. Consult with the project structural engineer and refer to your local building codes for proper wall support.

The following drawing shows a recommended approach to this type of installation. Please note that these drawings are not to scale. All fireplace drawings with correct dimensions are available on the Ortol website.

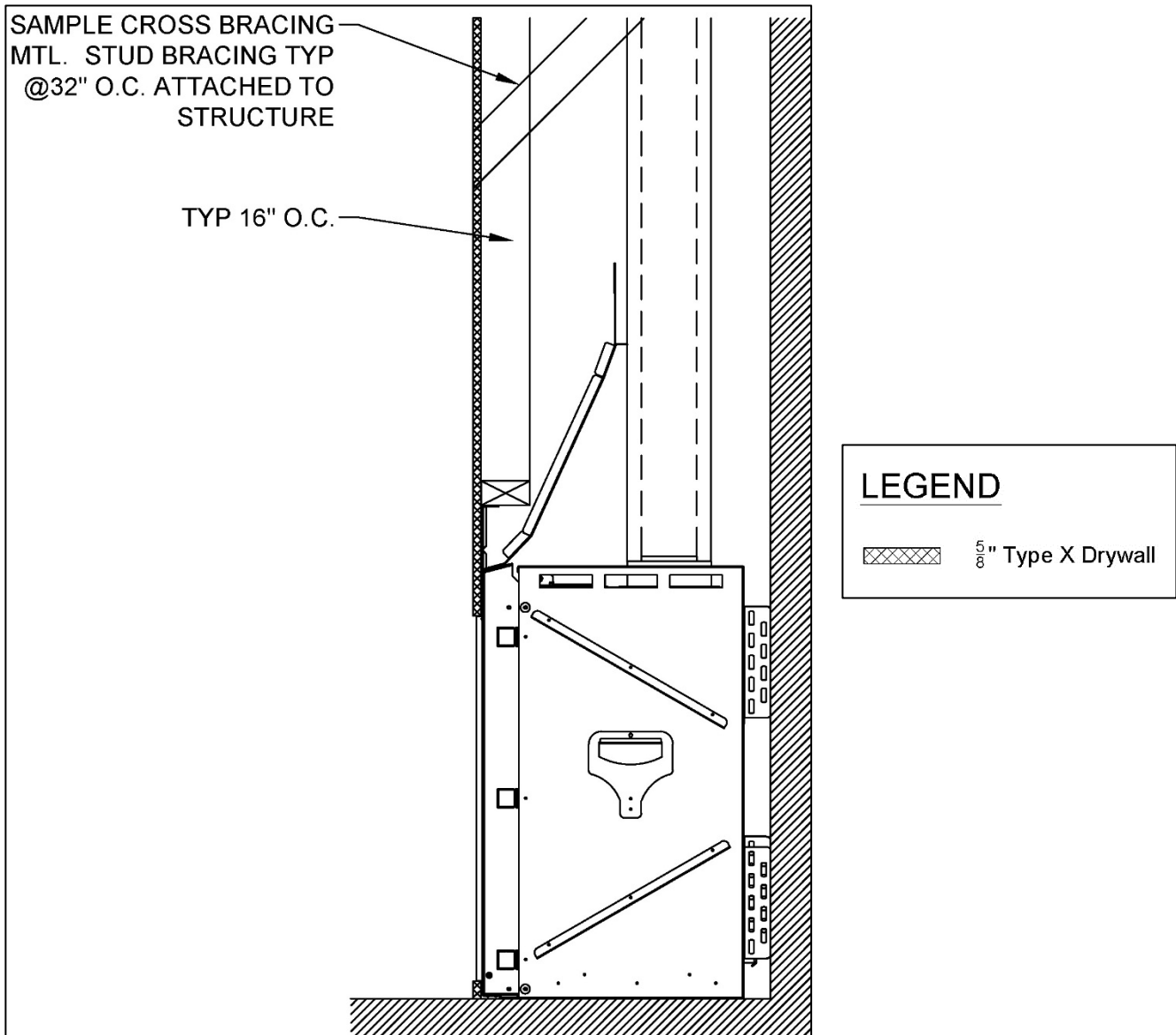

## Finishing

The following diagrams show various finished applications. **Diagrams apply to both combustible and non-combustible finishing material.**



### IMPORTANT NOTES:

- Finish requirements do not vary between fireplaces with a screen or double glass heat barrier. Diagrams below alternate depicting each heat barrier. This is for illustrative purposes only and does not mean a specific heat barrier is required for that application.
- All recessed installations must comply with applicable maximum overhang limit and side wall clearances. See “Maximum Overhang Depth” and “Clearance to a Side Wall” sections for details.
- No material is permitted to extend past the metal lip surrounding the fireplace viewing area. This area must be unobstructed to allow the heat barrier and inside glass panel to be removable.



**WARNING: Wood finish or floor/hearth extension may dry out, crack, warp or become discolored over time. Consult with floor manufacturer for required clearances to a heat source.**



## Flush Installation

Diagram applies to both combustible and non-combustible finishing material.

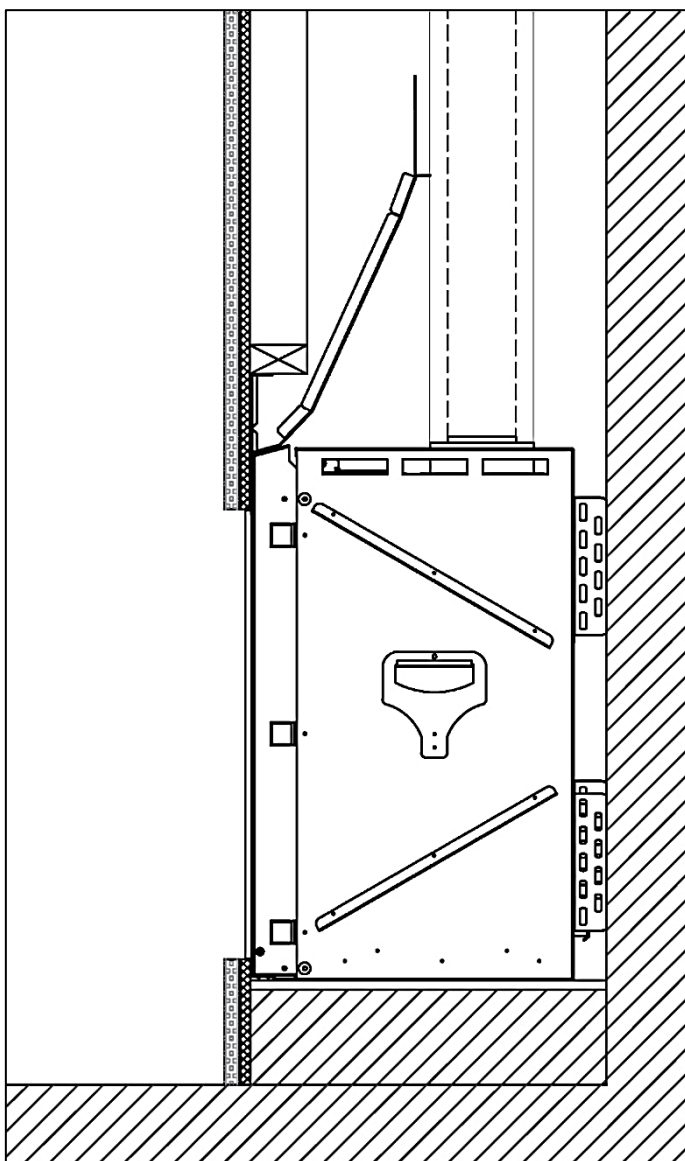
No material is permitted to extend past the metal lip surrounding the fireplace viewing area. This area must be unobstructed to allow the heat barrier and inside glass panel to be removable.



### LEGEND

-  5/8" Type X Drywall
-  Combustible Finish



**NOTE: A fireplace with a screen heat barrier and platform are shown for illustrative purposes only. These features are not a required part of the finish detail.**

## Recessed Installation

Diagram applies to both combustible and non-combustible finish material. The finish must maintain at least  $\frac{1}{8}$ " clearance to the fireplace to both the top and bottom recesses.

No material is permitted to extend past the metal lip surrounding the fireplace viewing area. This area must be unobstructed to allow the heat barrier and inside glass panel to be removable.

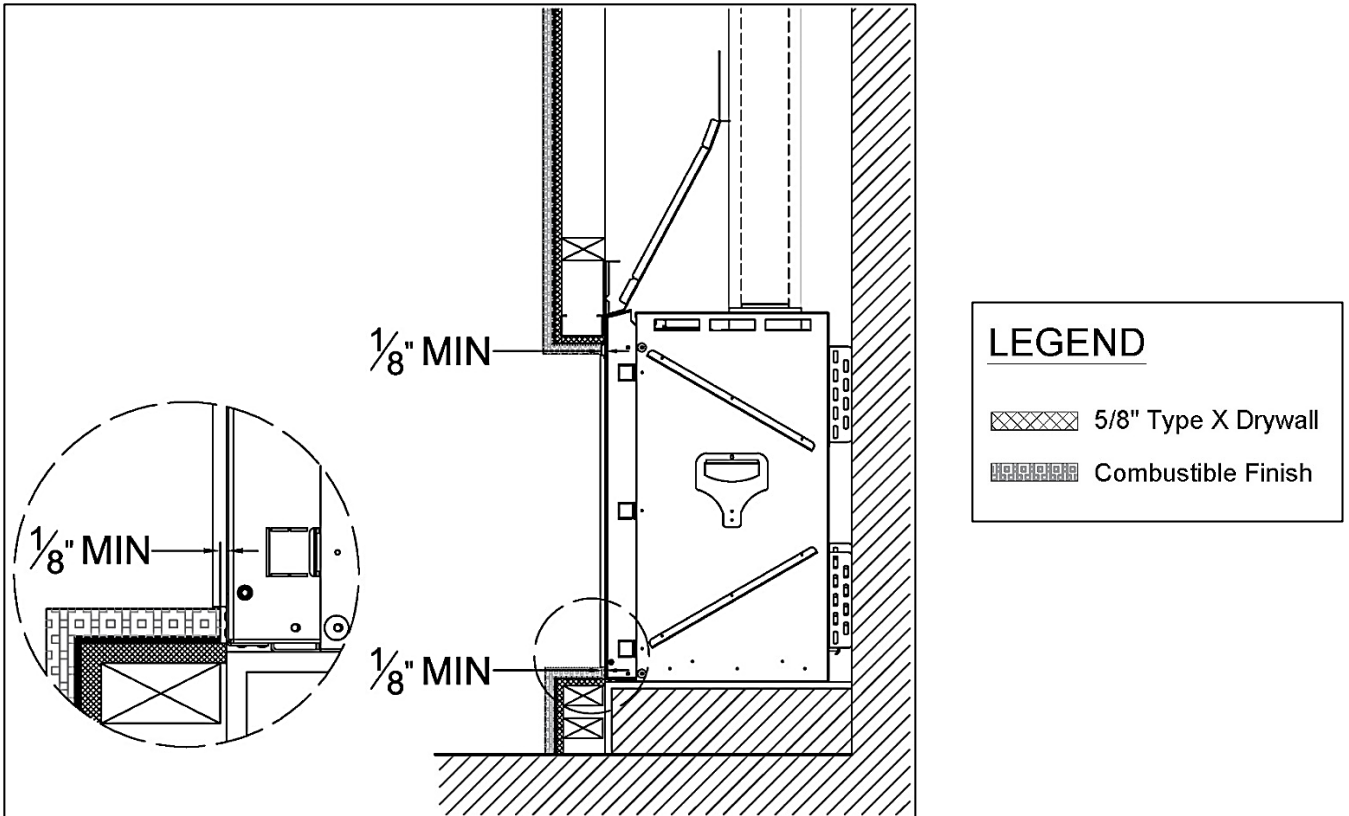

**NOTE:** A fireplace with a screen heat barrier and platform are shown for illustrative purposes only. These features are *not* a required part of the finish detail.

## Maximum Overhang/Mantle Depth

Overhang (aka Mantel) depth of a recessed fireplace must not exceed **12 inches**. Overhang depth is measured from the edge of the fireplace lip to the out-most part of the wall (including finish material). **Side overhang has no limit**. Finishing material on the underside of the overhang can be combustible or non-combustible. **Metal studs must be used for framing overhangs**.

Bottom recess (or "hearth extension") has no minimum or maximum depth requirement. If bottom recess depth exceeds 12 inches, ensure the structure can support the weight of a fireplace technician for servicing.

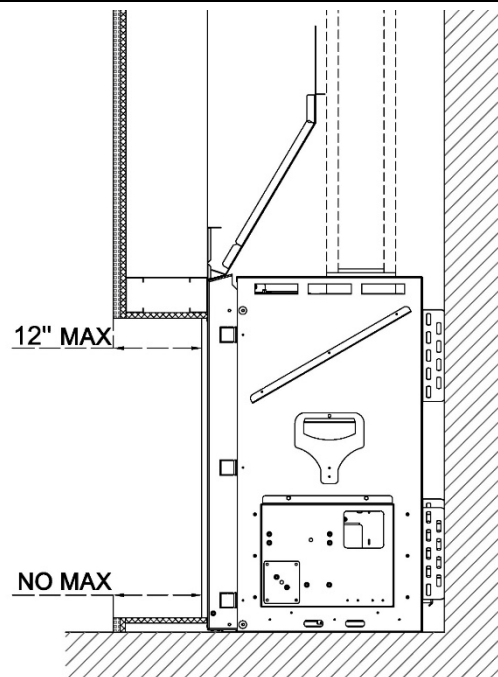

# Venting

## General Venting Requirements

The fireplace operates using a direct vent system and require a co-axial direct vent pipe. The fireplace must be properly connected to an approved vent system. Venting is not provided with the fireplace and must be sourced from one of the approved vent manufacturers mentioned in the table below. Proper installation, use, and maintenance of venting is determined by and can be acquired from the vent manufacturer.

Vent Requirements			
Fireplace Series	Vent Type	Vent Size	Approved Vent Manufacturers
Wilderness Traditional	Direct Vent	5x8 co-axial direct vent pipe (5" interior, 8" exterior)	Olympia: Ventis DuraVent: Direct Vent Pro ICC: EXCELDirect BDM: Pro-Form Direct Vent System Selkirk: Direct-Temp System
	Enervex Power Vent*		
	Ortal Power Vent*	3x5 co-axial direct vent pipe (3" interior, 5" exterior)	DuraVent: CVS line ICC: EXCEL PV Pipe

**Power Vent:** a fan-assisted direct vent system that boosts airflow for vent configurations with too much constriction. Review "Vent Configurations" section to determine if your fireplace needs a power vent.

 **NOTE:** See the Ortal Power Vent Manual for more details on power venting.

 **TERMINATION CAP NOTE:** Low Profile Termination Cap and Sconce Termination Cap can negatively impact flame appearance and are not recommended for use with the fireplace.

 **WARNING:** Do not combine vent components from different vent manufacturers. Please follow the manufacturer's instructions for vent system installation.

## Vent Configurations

The following sections provide information for calculating vent configuration distances and elbows. For vent configurations that cannot conform to these guidelines, consider Ortal's Power Vent System, or contact Ortal for assistance. Power Vent information can be found in the Power Vent Installation Manual.

**Please consider the following guidelines when determining vent configuration:**

### Elbows

- **Maximum Elbows:** Up to four 90° elbows can be used in the vent configuration. Two 45° elbows = one 90° elbow.
  - **45° Vertical Offset Exception:** Two 45° elbows in the vertical plane with a diagonal run in between is equal to **0 elbows**. They are not counted with other elbows in the vent configuration. This offset exception is applicable immediately on the top of the fireplace and anywhere else within the vent configuration.  
**The diagonal run between the two 45° elbows must be included when calculating vertical and horizontal distances.**
  - **45° Horizontal Offset:** Two 45° elbows that begin and end in the horizontal plane, with a diagonal run in between, is equal to **one 90° elbow**. Additionally, **3 feet** must be reduced from the total allowable horizontal run.  
**The diagonal run between the two 45° elbows must be included when calculating vertical and horizontal distances**
- **Exceeding two 90° Elbows:** For more than two 90° elbows, the minimum total vertical rise is **6 feet** for 90-250 models. This does not apply to 40-75 models.
- **Flat 90° Elbows:** For every flat 90° elbow (a 90° elbow that stays in the horizontal plane), **6 feet** must be reduced from the total allowable horizontal run. Up to two flat elbows are allowed.
  - Example: If max allowable horizontal run is 24 feet and 1 flat elbow is added, max run is reduced to 18 feet.

### Diagonal Runs

- **Calculating Diagonal Runs (D):** Diagonal (45°) vent runs have an equal combination of vertical and horizontal aspects. To include diagonal portions of your desired vent configuration when determining overall vent limitations, divide the diagonal distance in half. Add this value to the total vertical rise and total horizontal run distances in your vent configuration. Include these values when utilizing the Vent Configuration Tables below.
  - Example: 6 feet diagonal run = 3 feet vertical rise & 3 feet horizontal run

### Other

- **V Minimum:** This is the minimum amount of vertical rise required before the first *completely* horizontal (not diagonal) run.
- Any vent configuration that does not meet these parameters requires Ortal's review and approval.

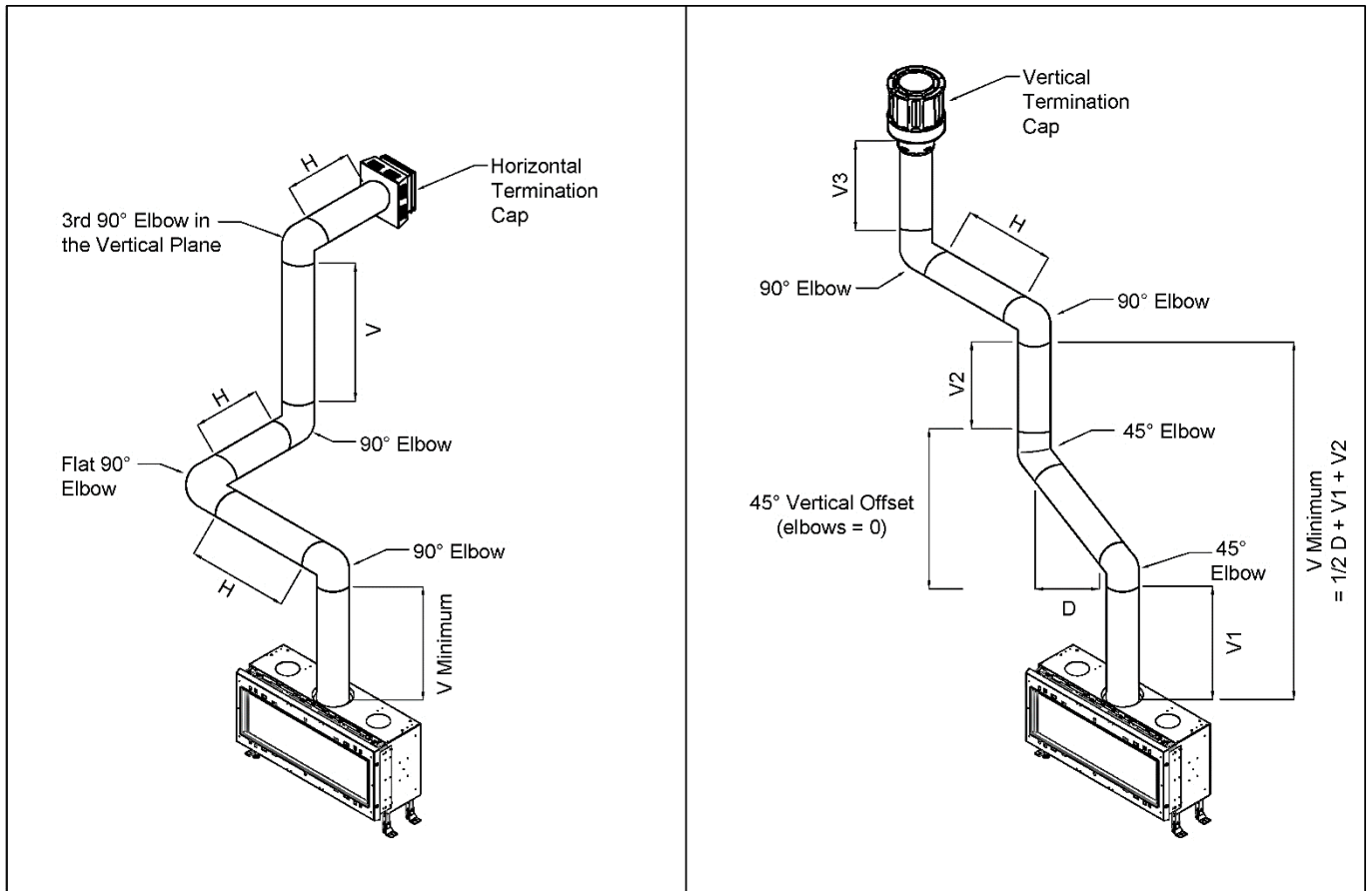

**! TERMINATION CAP NOTE:** Low Profile Termination Cap and Sconce Termination Cap can negatively impact flame appearance and are not recommended for use with the fireplace.

Allowable Maximum Horizontal Runs	
Wilderness Traditional Series Fireplaces	
V minimum = 3 feet	
Vertical (V)	Max Horizontal (H)
3 ft	12 ft
6 ft	24 ft
9 ft	24 ft
12 ft	21 ft
15 ft	21 ft
18 ft	18 ft
21 ft	15 ft
24 ft	12 ft
27 ft	12 ft
30 ft	12 ft
33 ft	12 ft
44 ft	0 ft

**! CHART NOTE:** Do not include the space elbows take up when calculating your vertical and horizontal distances.

## Vent Restrictor Sizing Guidelines

The restrictor sizing tables in this section determine the recommended restrictor for your vent configuration. These tables show Ortal's recommendations only. The Environment, gas type and other factors may affect the best restrictor choice.

### How to use the "Recommended Restrictor" tables:

- Find the total vertical rise in your vent configuration along the y-axis.
- Find the horizontal run in your vent configuration along the x-axis.
- Follow the desired rise and run values within the table until they meet. This value is the recommended restrictor size (in inches) for your vent configuration.

### Legend:

X: Vent configuration is not allowed. Power vent required.

0: No restrictor required.

Numbers other than 0: Represents the recommended restrictor (by width).

### Restrictor Sizes:

- 20mm (0.79")
- 30mm (1.18")
- 40mm (1.57")
- 50mm (1.97")
- 70mm (2.75")
- 85mm (3.35")

		Wilderness Traditional 36-42 V Minimum = 3 Feet											
		0'	3'	6'	9'	12'	15'	18'	21'	24'	27'	30'	33'
Total Vertical Vent Rise	44'	2.75"	X	X	X	X	X	X	X	X	X	X	X
	33'	2.75"	1.97"	1.97"	1.97"	X	X	X	X	X	X	X	X
	30'	2.75"	1.97"	1.97"	1.97"	X	X	X	X	X	X	X	X
	27'	2.75"	1.97"	1.97"	1.97"	X	X	X	X	X	X	X	X
	24'	2.75"	2.75"	2.75"	1.97"	X	X	X	X	X	X	X	X
	21'	2.75"	2.75"	1.97"	1.97"	1.57"	1.18"	X	X	X	X	X	X
	18'	1.97"	1.97"	1.97"	1.57"	1.57"	1.18"	0	X	X	X	X	X
	15'	1.97"	1.97"	1.97"	1.57"	1.57"	1.18"	0	0	X	X	X	X
	12'	1.97"	1.97"	1.57"	1.57"	1.18"	1.18"	0	0	X	X	X	X
	9'	1.57"	1.57"	1.18"	1.18"	0	0	0	0	0	X	X	X
	6'	1.18"	0	0	0	0	0	0	0	0	X	X	X
	3'	0	0	0	0	0	X	X	X	X	X	X	X
	0'	X	X	X	X	X	X	X	X	X	X	X	X

## Clearances

The following clearances apply to the vent system regardless of vent manufacturer.

Vent Clearances	
Sides: 1"	Applies to entire circumference when venting is oriented vertically. Clearance is to <b>any</b> material.
*Top: 3"	Applies to venting oriented horizontally or at an angle. Clearance is to <b>any</b> material.
Bottom: 1"	

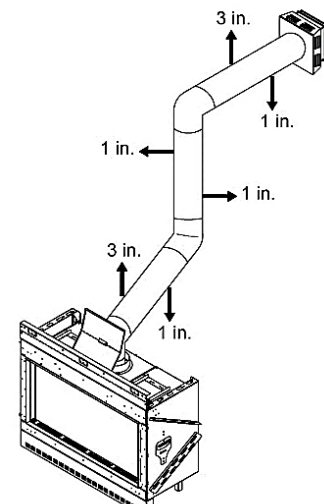

# Termination

## Horizontal Termination Clearance Diagram

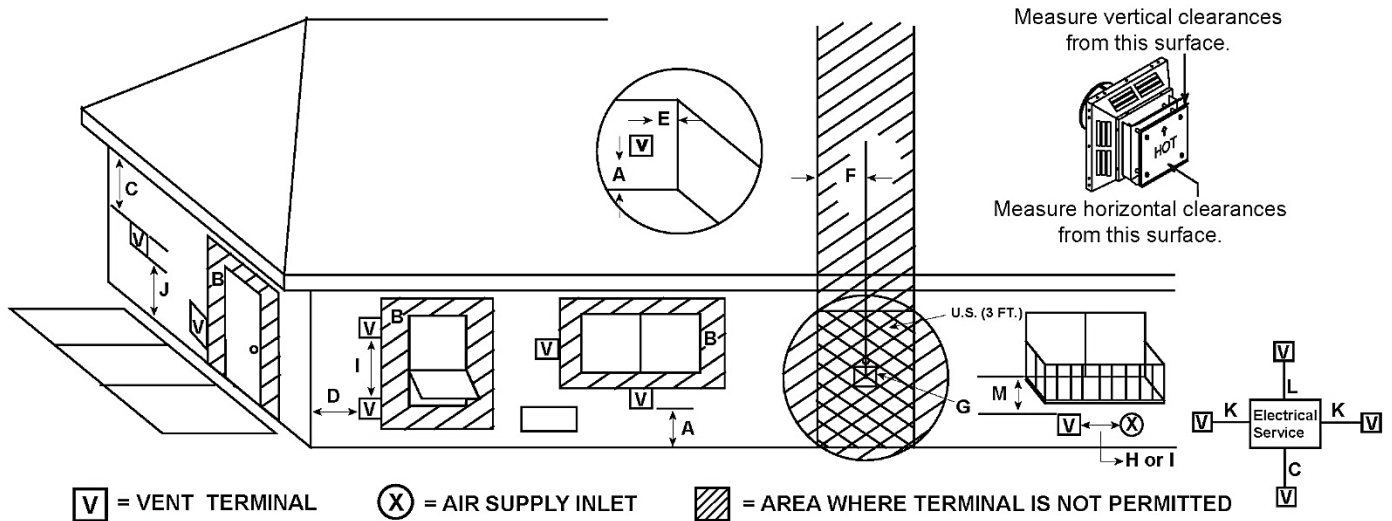

Location	Country	Minimum Clearance	Description
A	US & Canada	12 inches	Clearance above grade, veranda, porch, deck, or balcony. NOTE: On private property where termination is less than 7 feet above a sidewalk, driveway, deck, porch, veranda, or balcony, use of a listed cap shield is suggested.
B	US	≤ 50,000 BTU: 9 inches > 50,000 BTU: 12 inches	Clearance to an operable window or door. NOTE: Zero clearance to an inoperable window or door.
	Canada	12 inches	
C	US & Canada	24 inches	Vertical clearance to a <b>ventilated</b> soffit located above the vent termination.
		18 inches	Vertical clearance to an <b>unventilated</b> soffit located above the vent termination.
		42 inches	Vertical clearance to vinyl clad soffits and below electrical service.
D	US & Canada	9 inches	Clearance to an outside corner.
E	US & Canada	6 inches	Clearance to an inside corner.
F	US	N/A	Not to be installed above a gas meter/regulator assembly within 3 feet (90 cm) horizontally from the center-line of the regulator.
	Canada	3 feet	
G	US & Canada	3 feet	Clearance to gas service regulator vent outlet.
H	US	9 inches	Clearance to a non-mechanical air supply inlet to the building or the combustion air inlet to any other appliance. NOTE: Termination in a covered alcove space (spaces open only on one side and with an overhang) are permitted with the dimensions specified for vinyl or non-vinyl siding and soffits. 1. There must be 3 feet minimum between termination caps. 2. All mechanical air intakes within 10 feet of a termination cap must be a minimum of 3 feet below the termination cap. 3. All gravity air intakes within 3 feet of a termination cap must be a minimum of 1 foot below the termination cap.
	Canada	12 inches	
I	US	3 feet	Clearance to a mechanical (powered) air supply inlet. NOTE: Termination in a covered alcove space (spaces open only on one side and with an overhang) are permitted with the dimensions specified for vinyl or non-vinyl siding and soffits. 1. There must be 3 feet minimum between termination caps. 2. All mechanical air intakes within 10 feet of a termination cap must be a minimum of 3 feet below the termination cap. 3. All gravity air intakes within 3 feet of a termination cap must be a minimum of 1 foot below the termination cap.
	Canada	6 feet	
J*	US & Canada	7 feet	Clearance above paved sidewalk or a paved driveway located on <b>public</b> property. NOTE: On private property where termination is less than 7 feet above a sidewalk, driveway, deck, porch, veranda, or balcony, use of a listed cap shield is suggested. *a vent shall not terminate directly above a sidewalk or paved driveway which is located between two single family dwellings and serves both dwellings.
K	US & Canada	6 inches	Clearance from sides of electrical service. NOTE: Location of the vent termination must not interfere with access to the electrical service.
L	US & Canada	12 inches	Clearance above electrical service. NOTE: Location of the vent termination must not interfere with access to the electrical service.

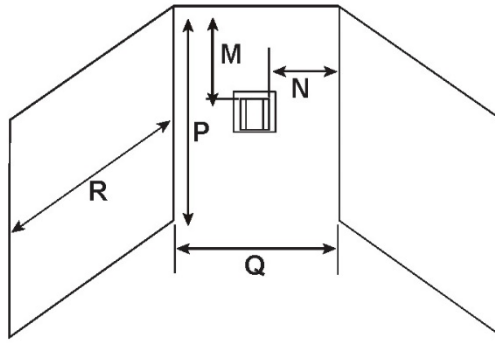

Covered Alcove: spaces open only on one side and with an overhang

Horizontal Termination Clearances Continued: Covered Alcove Application			
Location	Country	Minimum Clearance	Description
COVERED ALCOVE APPLICATION	M	US & Canada	16 inches Clearance under <b>non-vinyl</b> veranda, porch, deck, balcony, or overhang. NOTE: Termination in a covered alcove space is permitted with the dimensions specified. 1. There must be 3 feet minimum between termination caps. 2. All mechanical air intakes within 10 feet of a termination cap must be a minimum of 3 feet below the termination cap. 3. All gravity air intakes within 3 feet of a termination cap must be a minimum of 1 foot below the termination cap.
	N	US & Canada	6 inches Non-vinyl sidewalls.
			12 inches Vinyl sidewalls.
	P	US & Canada	8 feet Alcove height.
	Q	US & Canada	See table below. Alcove width (dependent on number of caps in the space).
R	US & Canada	See table below. Alcove depth (dependent on number of caps in the space).	

# Vent Caps	$Q_{\text{MINIMUM}}$	$R_{\text{MAXIMUM}}$
1 vent cap	3 feet	$2 \times Q_{\text{ACTUAL}}$
2 vent caps	6 feet	$1 \times Q_{\text{ACTUAL}}$
3 vent caps	9 feet	$\frac{2}{3} \times Q_{\text{ACTUAL}}$
4 vent caps	12 feet	$\frac{1}{2} \times Q_{\text{ACTUAL}}$
$Q_{\text{MIN}} = \# \text{ vent caps} \times 3$		$R_{\text{MAX}} = (\frac{2}{\# \text{ vent caps}}) \times Q_{\text{ACTUAL}}$

**! HORIZONTAL TERMINATION CAP CLERANCES - NOTES:**

- If exterior walls are finished with vinyl siding, it is *required* that a vinyl protector kit be installed.
- Vent system termination is not permitted in screened porches.
- Vent system termination is permitted in porch areas with two or more sides open. You must follow all side walls, overhang and ground clearances as stated.
- Termination caps may be hot. Consider their proximity to doors or other traffic areas.

# Vertical Termination Clearance Diagram

## Minimum Height From Roof To Lowest Discharge Opening

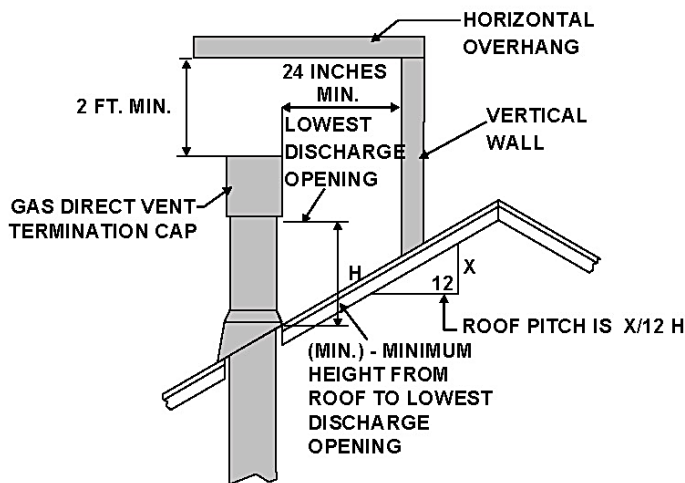

Roof Pitch	H (Min.) Ft.
Flat to 6/12.....	1.0*
Over 6/12 to 7/12.....	1.25*
Over 7/12 to 8/12.....	1.5*
Over 8/12 to 9/12.....	2.0*
Over 9/12 to 10/12.....	2.5*
Over 10/12 to 11/12.....	3.25
Over 11/12 to 12/12.....	4.0
Over 12/12 to 14/12.....	5.0
Over 14/12 to 16/12.....	6.0
Over 16/12 to 18/12.....	7.0
Over 18/12 to 20/12.....	7.5
Over 20/12 to 21/12.....	8.0

\*H min. may vary depending on regional snowfall. Refer to local codes.

## Staggered Termination Caps

A	B
6 in. (minimum) up to 24 in.	18 in. minimum
24 in. and over	0 in. minimum

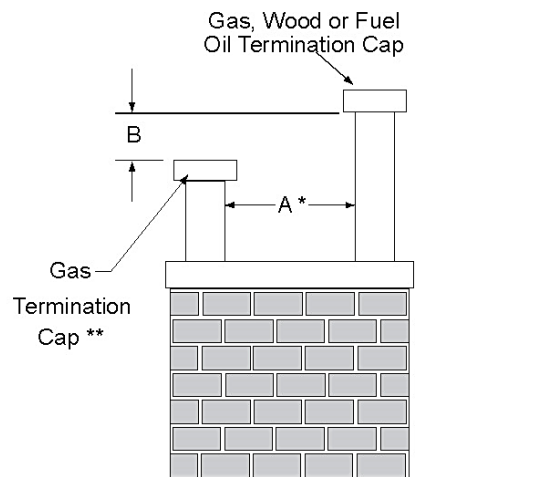

\* If using decorative cap cover(s), this distance may need to be increased. Refer to the installation instructions supplied with the decorative cap cover.

\*\* In a staggered installation with both gas and wood or fuel oil terminations, the wood or fuel oil termination cap must be higher than the gas termination cap.

### Notes:

1. Maintain a minimum of 2 feet clearance between edge of vertical termination and perpendicular wall.
2. If terminating near window, keep minimum of 2 feet clearance between window and vent termination.
3. All mechanical air intakes (such as an Energex power vent) within 10 feet of a termination cap must be a minimum of 3 feet below the termination cap.
4. All gravity air intakes within 3 feet of a termination cap must be a minimum of 1 foot below the termination cap.

**NOTE:** This chart does not apply to a chimney shroud application. See the "Chimney Shroud" section for more information.

**TERMINATION CAP NOTE:** A Low Profile Termination Cap can negatively impact flame appearance and is not recommended for use with the fireplace.

## Chimney Shroud

### Top Open

Keep a minimum **6-inch** clearance around the diameter of the cap's side edge and extending above and below the cap.

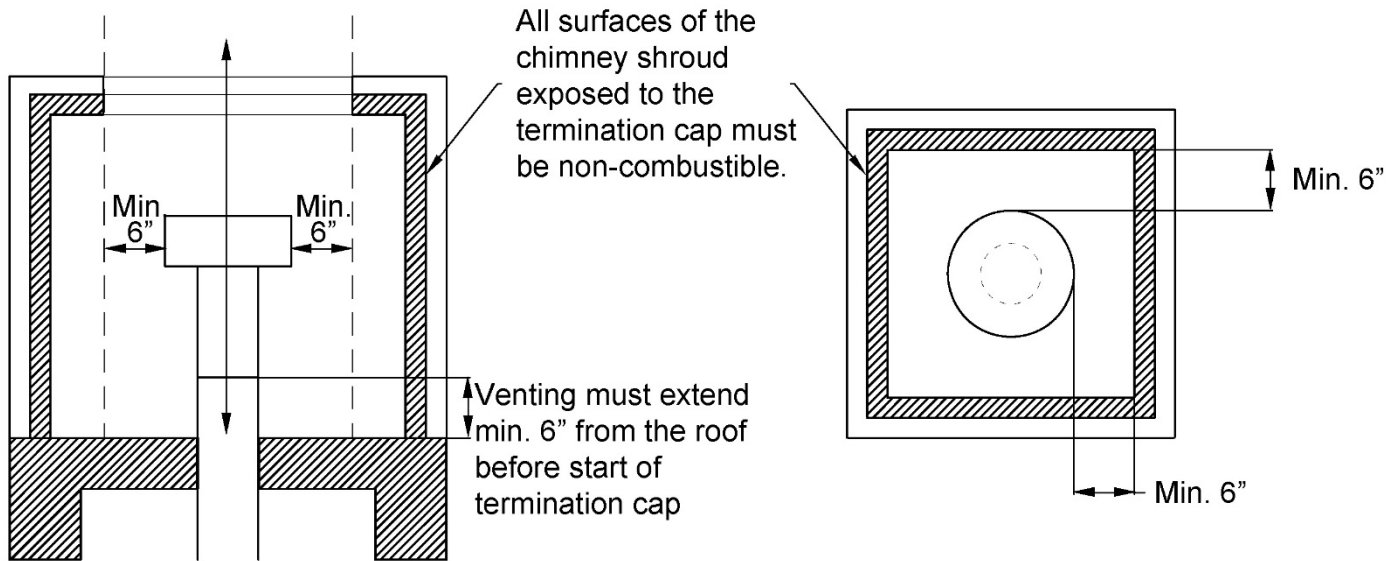

### Sides Open

Keep a minimum **6-inch** clearance around the diameter of the cap's side edge, and a minimum **10-inch** clearance above the top of the cap. For openings in the shroud, make sure to allow for enough air flow space to release the exhaust gases and allow the vent to operate properly.

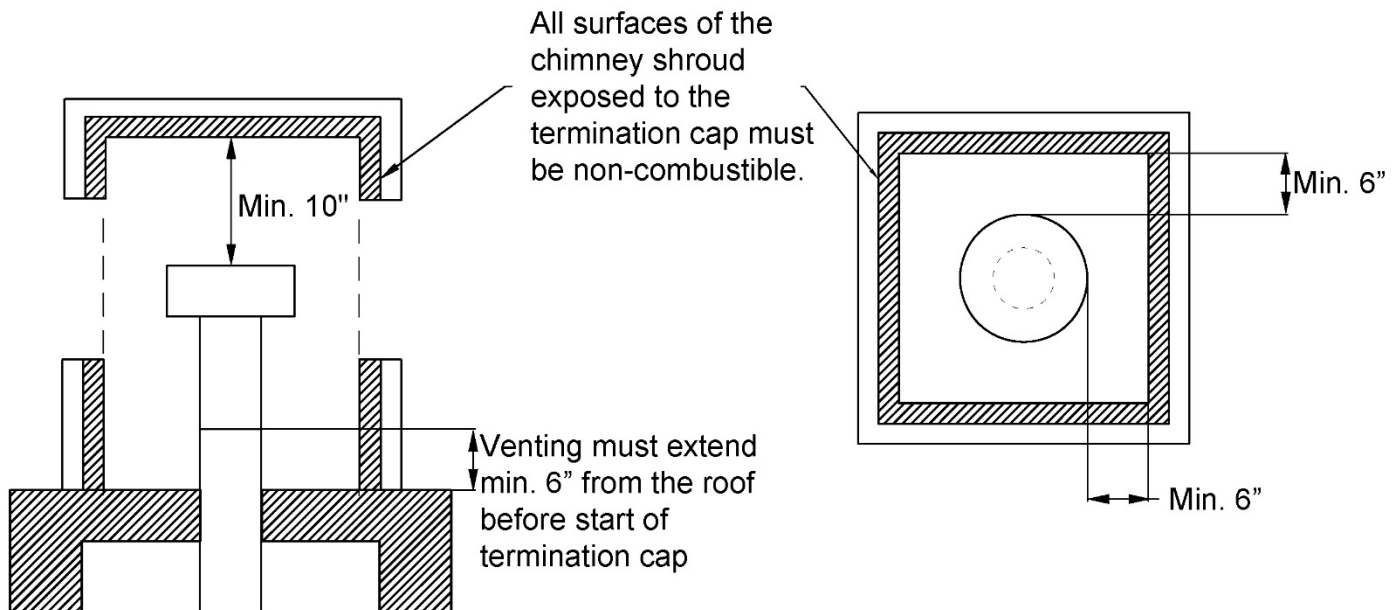

## Vent Installation

Venting must be installed to meet the requirements as detailed in the following sections in conjunction with the vent system manufacturer's installation instructions. Venting must be supported by the structural surrounding and not by the fireplace. Each offset (elbow) must be strapped to reduce movement or possible disconnection.

The first section of venting must be secured to the fireplace starter collar with a minimum of 3 sheet metal screws no longer than 1/2". DO NOT use silicone to seal the sections. If sealing is required by the vent manufacturer or local code, use Mil-Pac sealant or equivalent.

**⚠ WARNING: Do not combine vent components from different vent manufacturers. Please follow the manufacturer's instructions for vent system installation.**

## Vent Maintenance

Regular inspection of the vent system by a qualified service technician is recommended every six months. The following maintenance routing is recommended:

- Inspect for excessive condensation, e.g., water droplets forming in the inner lining, and subsequently dripping from the joints. This can cause corrosion in the system.
- Check for corrosion in areas exposed to the elements. Components with rust spots or holes must be immediately replaced.
- Ensure that there is no foreign material in the vents. Survey by removing the cap and shining a light down the vent.
- If possible, check all vent joints to make sure nothing has been disturbed or loosened.

## Co-Axial to Co-Linear Conversion

This section explains how the fireplace can be inserted into an existing solid fuel burning fireplace chimney by converting the co-axial venting to co-linear.

### ! IMPORTANT NOTES:

- The fireplace must be vented vertically to the outside and must use one of the approved co-linear flexible ducting systems or a co-axial flexible ducting system.
- Air intake (as applicable) and heat release is still required per installation guidelines (even when venting through a chimney). All other building requirements still apply.
- Restrictor use is not required when using co-linear venting.

### ! WARNINGS:

- If the vent system of this appliance is disconnected for any reason, the vent and air intake systems must be properly reassembled and resealed before this appliance is put into use.
- Proper installation of the vent system, as required in this manual, is vital to the performance of this appliance. Oversights or failure to conform to all installation requirements will void the applicable warranty.
- This appliance must be properly connected to a venting system in accordance with the Ortal's installation instructions. Operation of this appliance when not connected to a properly installed and maintained venting system can result in carbon monoxide (CO) poisoning and possibly death.
- Co-linear flexible aluminum venting must be professionally inspected periodically for corrosion and damage and replaced when necessary. If the installation does not allow for future inspection or replacement of the flexible aluminum venting, then stainless steel vent liners should be used.
- Co-linear portion of vent system may only be installed within a solid-fuel burning fireplace and chimney.
- The appliance must not be connected to a chimney flue serving a separate solid-fuel burning appliance.

The plan to install a gas fireplace inside an existing solid fuel burning fireplace chimney must include inspection and cleaning of the fireplace cavity and the entire chimney system. The chimney top, especially masonry chimneys and wood framed chimney tops must be inspected, and the top surface must be repaired or replaced, if necessary. Unlined chimney flues are the most vulnerable to mortar corrosion and damage. These flues must be inspected, and repair must be done before dropping the flex vent liner for this insert.

If you encounter a badly deteriorated or completely damaged firebox, do not proceed. These damaged structures must be reviewed by structural Engineers and Local Building Code officials must approve the repair work prior to this Insert being installed in such a damaged cavity.

Series	Vent Size	Adapter (BDM or equivalent*)	Split Pipe Size	Termination Cap (BDM or equivalent*)
Wilderness Traditional Series	5x8	5"x8" to 4"x3" (DVR8-A34)	4"x3"	4"x3" (PV3-VCS34B)

\*BDM component part numbers are offered as a suggestion. Components from the following companies may also be used: Duravent, Olympia, ICC, and Selkirk.

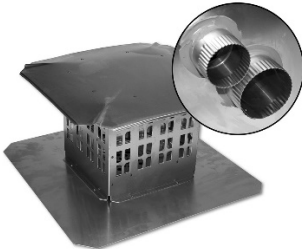
Example of Co-axial to Co-linear Appliance Adapters (BDM)	Example of Co-linear Terminal (BDM)
	

## Vent Configuration

- **Minimum Vertical Rise:** 10 feet (see diagram below)
- **Maximum Vertical Rise:** 40 feet (see diagram below)
- **Offsets:** Two 45° offsets may be used directly on the fireplace with up to a 6-foot section between them. The minimum vertical rise starts above them (see diagram below). No other offsets are permitted in the vent configuration. Offsets are not required to have.

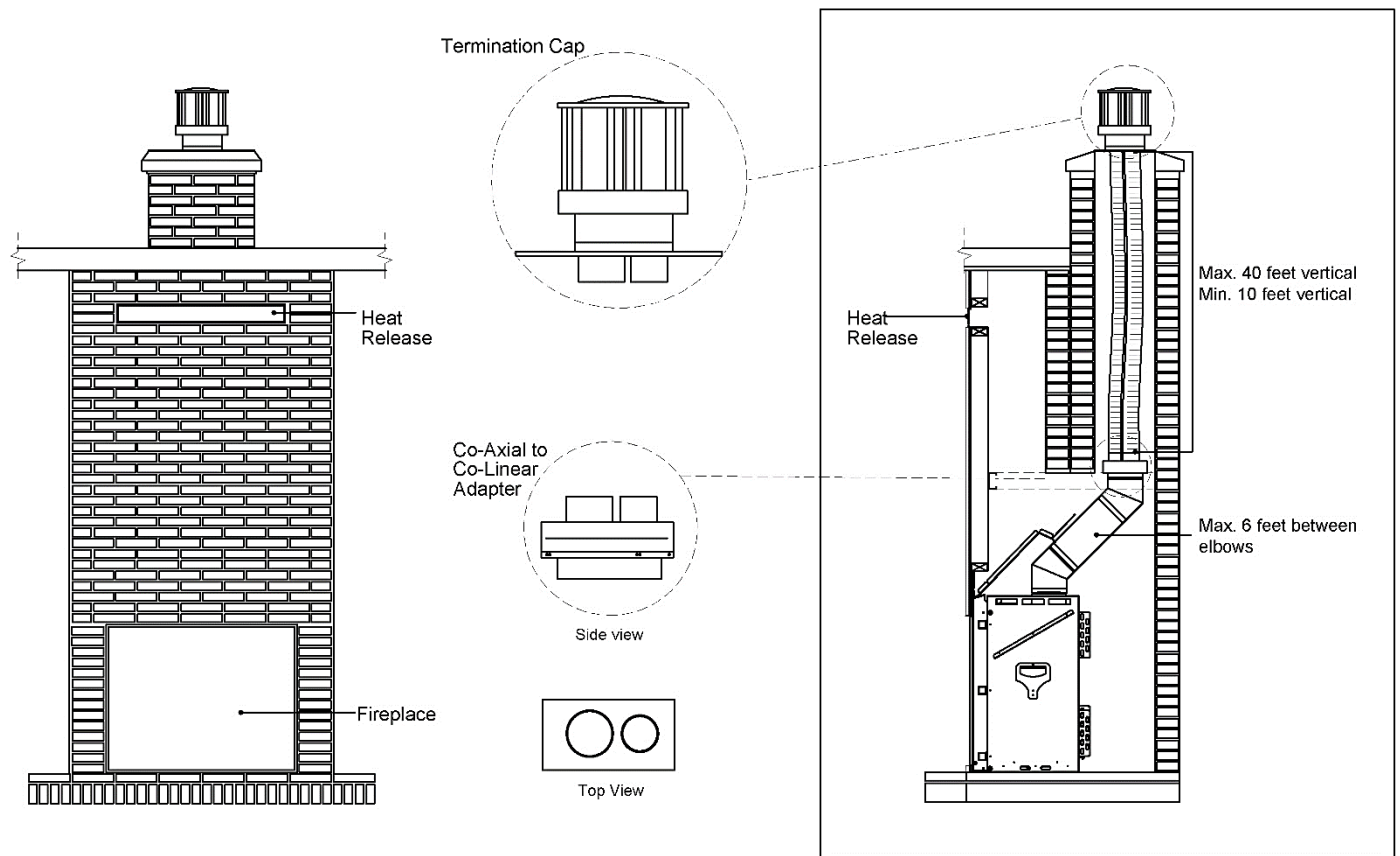

## Gas

The fireplaces are approved for use with natural gas (NG) or propane (LP) only. No other fuel types are permitted.

## Gas Pressures

Fireplace Series	Burner	Electrical Requirements	Gas Type	Inlet Pressure		Manifold Pressure	Heat Input (BTU/hr)		Orifice Size (by log)
				Min	Max		Min	Max	
Wilderness Traditional	Driftwood, Valley Oak, or Birch Firelogs	Dedicated Outlet: 120v 15-amp 60hz	Natural Gas	7.0	11.0	4.7	15,696	32,163	320-160-320 380
			Propane	11.0	13.0	4.7	21,400	31,400	90-60-90 180

\*Orifice Size, Top Row (left to right): Left log, center log, right log. Bottom Row: Back log.

**!** NOTE: It can take up to 20 minutes for the flames to turn yellow.

## Routing the Gas Line

The gas and electrical components are located in the gas/electrical compartment on the left side on the outside of the fireplace. This compartment houses the gas valve, a single-gang outlet, and the electrical receiver. Correctly size and route the gas supply line from the supply regulator to the top left opening of this compartment, as per the requirements outlined in the latest edition of the National Fuel Gas Code, NFPA 54 (USA) or CAN/CSA-B1491 (Canada).

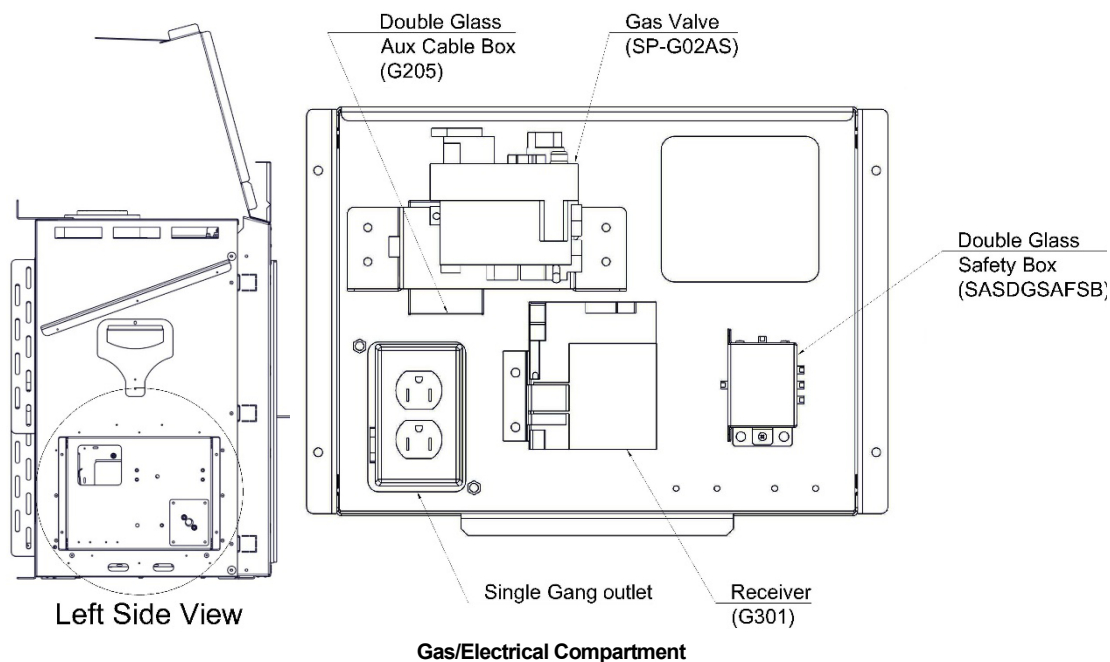

A gas shut-off valve and a 12" gas flex connector are provided with every fireplace. The location of the gas shut-off valve is dependent on local codes and requirements. Check with your authority having jurisdiction for more information.

**WARNING:** The main gas valve must be installed to allow complete disconnection of the fireplace from the gas supply piping system for servicing purposes.

## Access Panel

It is unnecessary to provide an access panel in the fireplace chase (see note below for exception).

Components are accessed through the fireplace via a built-in access panel on the inner left side of the fireplace.

**NOTE:** An access panel, or some other form of clear access, is required for power vented fireplaces. For servicing purposes, the power vent control box (located at the fireplace) must be easily accessible in a way that does not require removal of the fireplace glass.

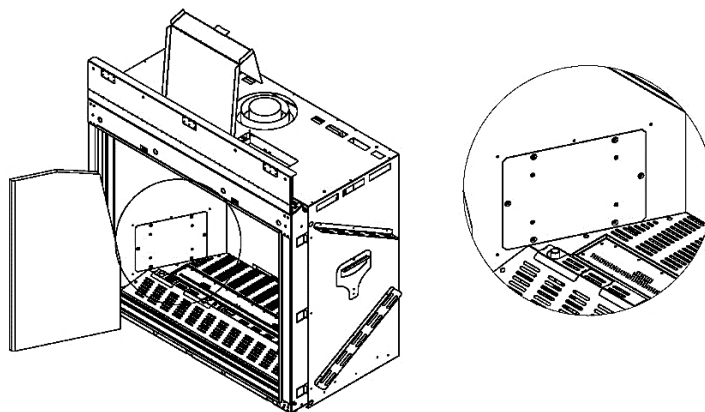

Built-in Access Panel

## Gas Conversion

For gas conversion (NG to LP or LP to NG) in the field, Firelogs for the desired gas type must have been ordered and on site before gas conversion can occur. Firelog installation and gas conversion must be performed only by technicians who have specific authorization by Ortal to change these components. Using parts from other manufacturers or having an unauthorized party performing the conversion will void your fireplace's warranty. Conversion instructions are supplied with the kit.

Driftwood Firelog Set for Wilderness Traditional Series Fireplaces, Natural Gas: **SKU: GCLNDW700-US**

Driftwood Firelog Set for Wilderness Traditional Series Fireplaces, Propane: **SKU: GCNLDW700-US**

Valley Oak Firelog Set for Wilderness Traditional Series Fireplaces, Natural Gas: **SKU: GCLNVLYOKB703LO**

Valley Oak Firelog Set for Wilderness Traditional Series Fireplaces, Propane: **SKU: GCNLVLYOKB703LO**

Birch Firelog Set for Wilderness Traditional Series Fireplaces, Natural Gas: **SKU: GCLNBIRCHB703LO**

Birch Firelog Set for Wilderness Traditional Series Fireplaces, Propane: **SKU: GCNLBIRCHB703LO**

### NOTES:

- Log sets for NG and LP have different SKUs. Please consult the price list to ensure you have the correct SKU.
- LP logs do not contain nickel strands inside the logs. NG logs do contain nickel strands.

## High Altitude Requirements

For elevations above 2,000 feet, the fireplace shall be re-rated 4% for each 1,000 feet above sea level.

In Canada: Input ratings are certified without a reduction of input rate for elevations up to 4500 feet above sea level. Please consult provincial and/ or local authorities having jurisdiction for installations at elevations above 4500 feet.

## → Gas and Electrical Components

Assemblies and components are listed and described in the tables following the figure.

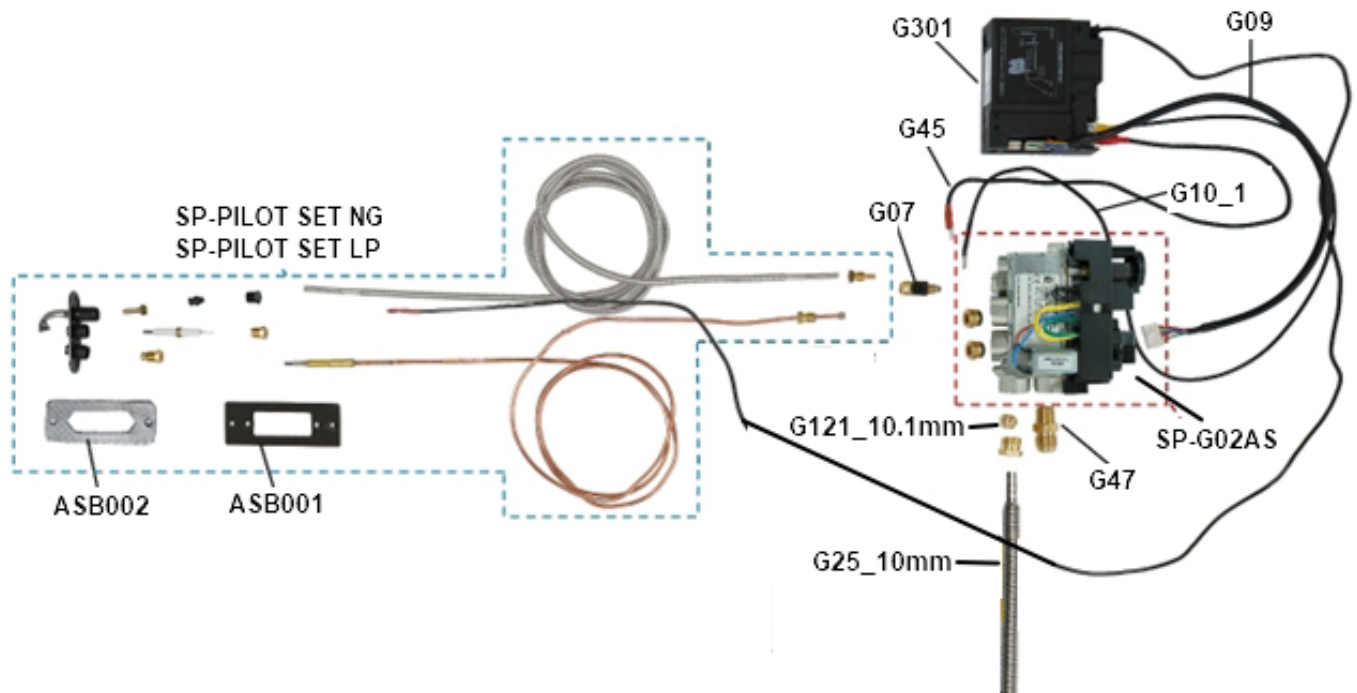

Part Number	Description
ASB001	Pilot Bracket
ASB002	Pilot Gasket
SP=PILOT SET NG	NG Pilot Assembly
SP-PILOT SET LP	LP Pilot Assembly
G10_1	Yellow Cable
G45	Red Cable
G09	8 Pin Wire Harness

Part Number	Description
G121_10.1mm	Main Burner Fitting
G25_10mm	Burner Gas Tube
SP-G02AS	Mertik Gas Valve
G07	Thermocouple Block
G47	Main Line Gas Fitting for Valve
G301	Symax Receiver

The manufacturer of Ortal's gas and electrical components is Mertik Maxitrol. For information on these components, please visit the manufacturer's website: [www.mertikmaxitrol.com](http://www.mertikmaxitrol.com)

## Electrical

- ⚠ WARNINGS:**
- Electrical work should be performed by a qualified licensed electrician, per local code.
  - Disconnect the power supply before servicing any electrical components.
  - Use of an AC Adapter other than the one provided with the fireplace (manufactured by Mertik Maxitrol) may render the system inoperable.
- ⚠ NOTE:** Any device that functions using the same radio frequency as the handset will be affected when remote-controlled handset is in use.

## Electrical Requirements

The fireplace is supplied with a 120V power cord to connect the fireplace light control module into the electrical receiver to a single gang outlet (120V, 15 amp, 60Hz). AC Adapter is required for operation.

The electrical components are located in the gas/electrical compartment on the left side on the outside of the fireplace. This compartment houses a single-gang outlet which both the power cord from the light control module and double glass safety box plug into.

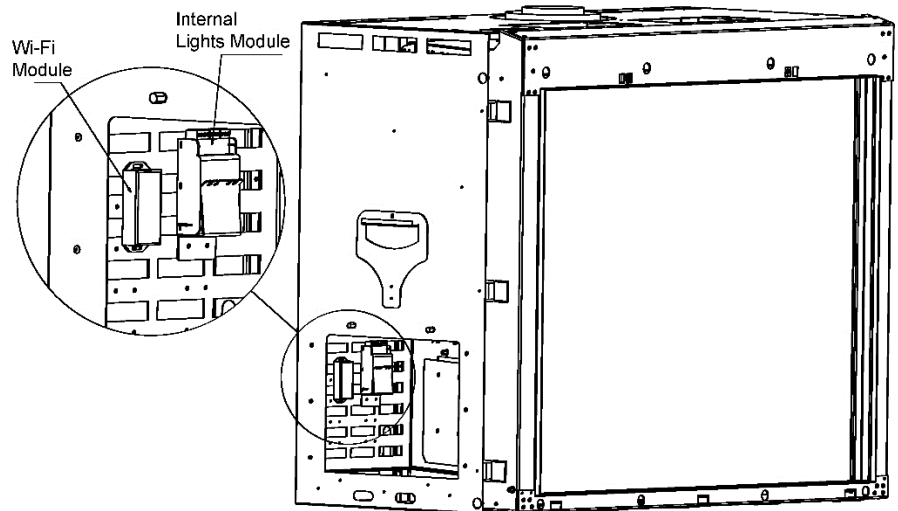
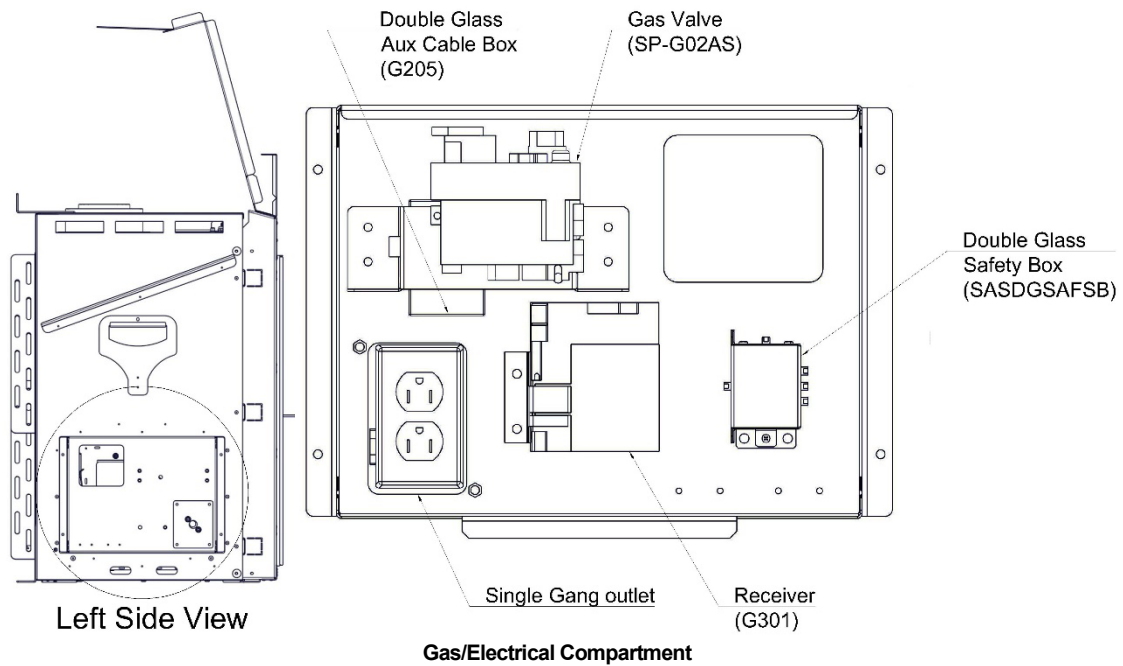

The Wi-Fi and Internal Lights Modules are located just behind the access panel inside the gas and electrical cavity of the fireplace (see "Access Panel" section for details on the access panel).



Wi-Fi is an optional accessory and does not come standard with the fireplace.

## Pairing the Remote and Receiver

To set up the remote-control device to operate the fireplace, follow the following guidelines to pair the remote and receiver unit on the same radio frequency.

- Press and hold the receiver's reset button until you hear two beeps. The first beep is short, and the second beep is long. After the second beep, release the reset button.



- Within the subsequent 20 seconds, press the following button depending on the mode of operation:
  - **10-Button Handset:** Press the  button. "CONN" and a running number from 1 to 8 will appear on the handset display confirming that the synchronization and data exchange are in process.
  - **Puck Handset:** Press and hold the  button approximately 4 seconds.
  - **Wall Switch:** Use the 10-button handset to synch with the receiver. Once the remote and receiver are paired, the wall switch will function normally.
  - **MyFire App:** Use the 10-button handset to synch with the receiver. Once the remote and receiver are paired, the App will function normally.
- You will hear two short beeps confirming the connection.

### NOTES:

- If you hear one long beep, this indicates the connection has failed or the wiring is incorrect.
- The connection between remote and receiver only needs to be made once and is not required after changing the batteries in the remote.

## → Wiring Diagrams

The following diagrams show the electrical wiring required for different feature combinations.

### Wiring Diagram: Screen Fireplace with Interior Lighting

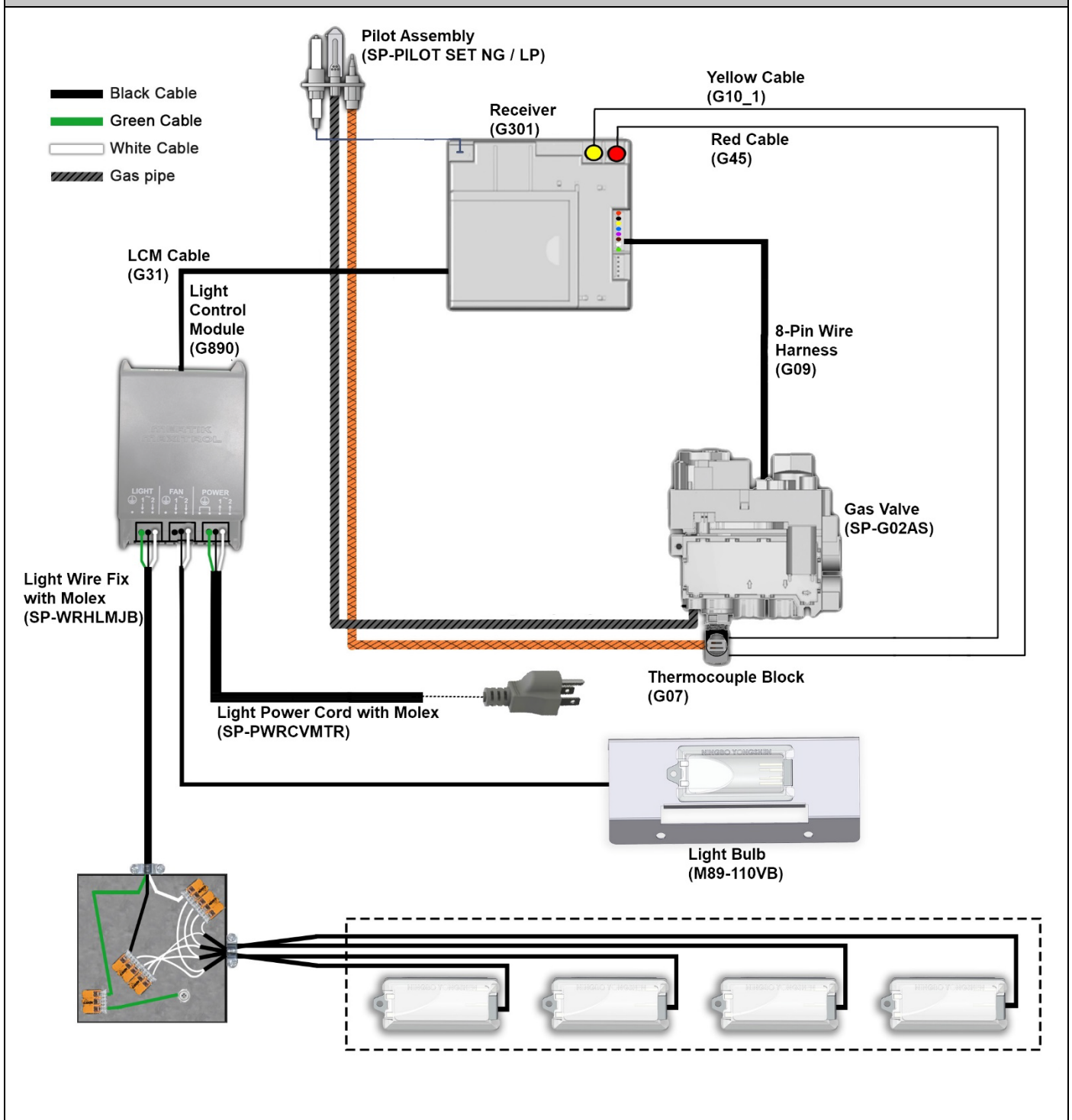

## Wiring Diagram: Double Glass Fireplace with Interior Lighting

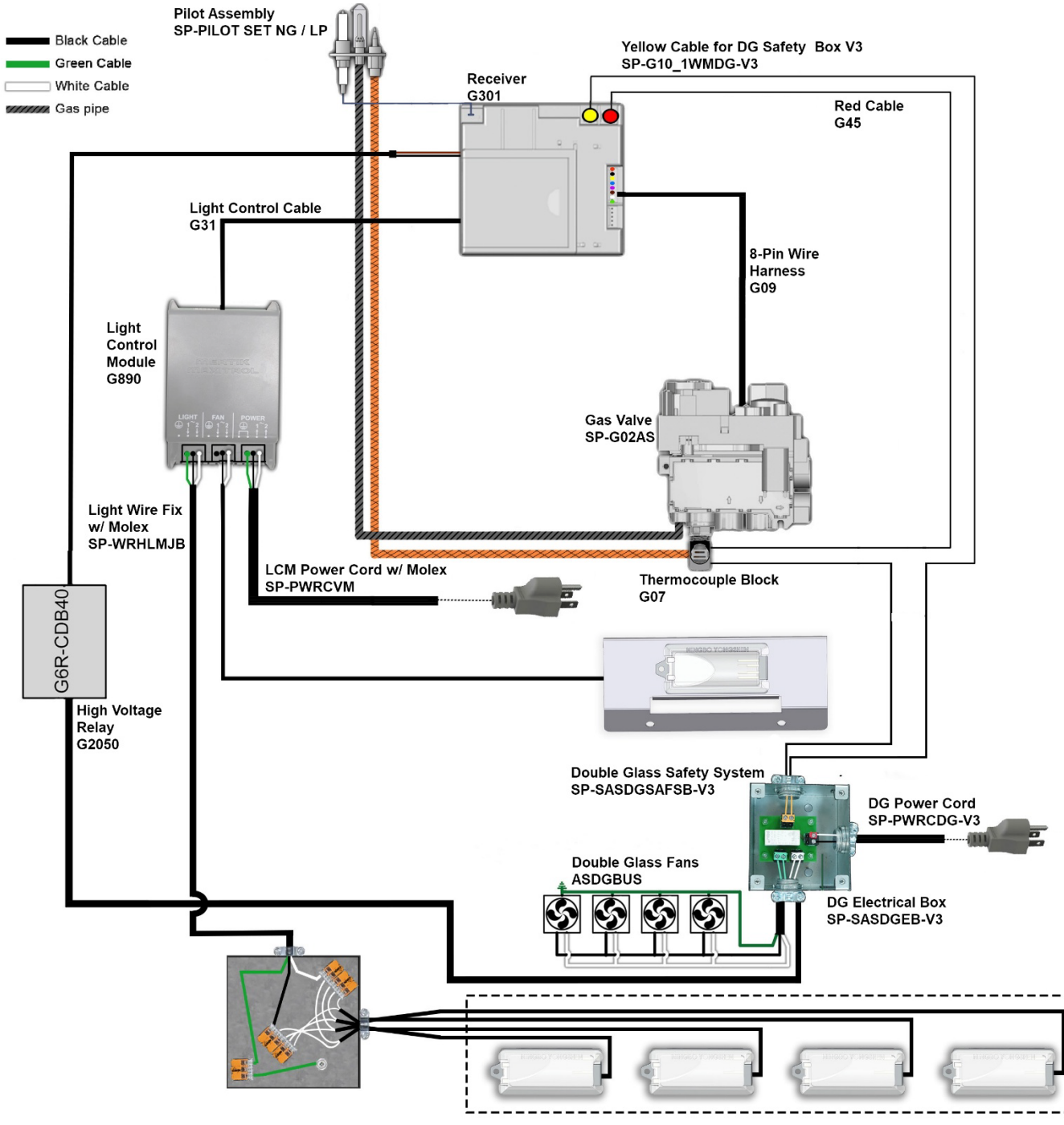

**NOTE:** Version 3 Double Glass Safety Box cut in serial number is 45981.

# Home Automation Wiring Diagram

Use the following wiring diagram to connect fireplace control a hardwired home automation system.

## Contacts Options/Operation

**Ignition:** Close contacts 0 (orange) and 2 (brown) simultaneously for 1 second. Fireplace automatically goes to high after ignition.

**Up Flame:** Close contacts 0 (orange) and 1 (red) simultaneously. The contact needs to be closed for 12 seconds to turn the motor from end-stop to end-stop.

**Down Flame:** Close contacts 0 (orange) and 3 (black) simultaneously. The contact needs to be closed for 12 seconds to turn the motor from end-stop to end-stop.

**Off:** Close contacts 0 (orange) and 2 (brown) simultaneously for 1 second.

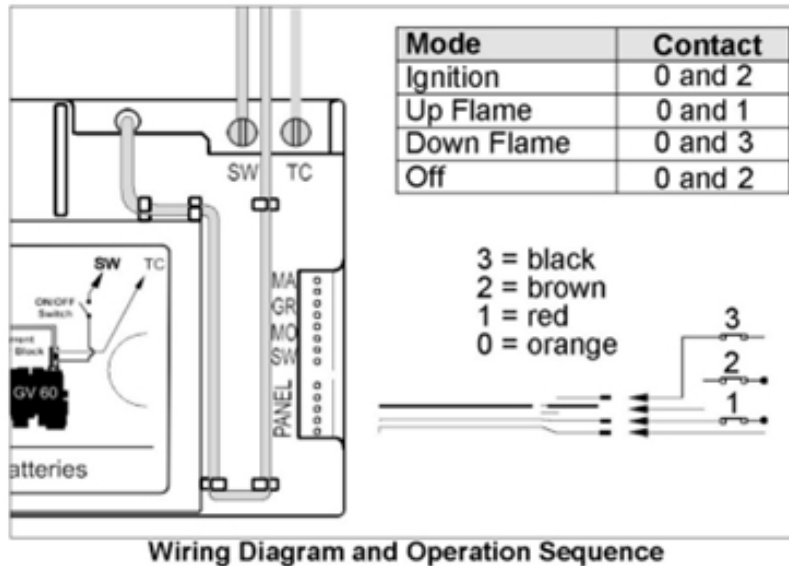

**Mode of Operation:** The external source provides ON and OFF operation only. The Timer/Thermostat handset provides all other functions.

**NOTICE:** The Timer/Thermostat handset in Thermostatic Model controls the room temperature even if the fire is turned on by the external source. If the handset is in Manual Mode, the fire will go to High Fire in the next cycle of external operation.

**NOTE:** This wiring diagram is for hardwired smart home systems only and will not connect the fireplace to a wireless system.

# Firelog Setups

## Firelog Installation Warnings

- **Firelogs are fragile.** Handle them gently to prevent damage to their paint or to the fireplace.
- **Arrange firelogs as shown in the section below.** Do not arrange them in any other way. If firelogs are not installed per installation instructions, flame impingement and improper combustion may occur and result in soot and/or excessive production of carbon monoxide (CO). Carbon monoxide is a toxic, colorless, and odorless gas.
- **Do not install the firelog media until** fireplace installation is complete, the gas line is connected and tested for leaks, and initial burner operation has been inspected and approved.
- **Keep 1 inch around the pilot (behind pilot hood) completely clear of any media or debris.** Contact between the nickel strands and the spark plug cable may lead to failure operating the fireplace.
- **Do not cover the main burner holes** (marked in the image below) unless otherwise stated in this manual. Blocking the holes can cause a gas release that could cause an explosion in the fireplace.

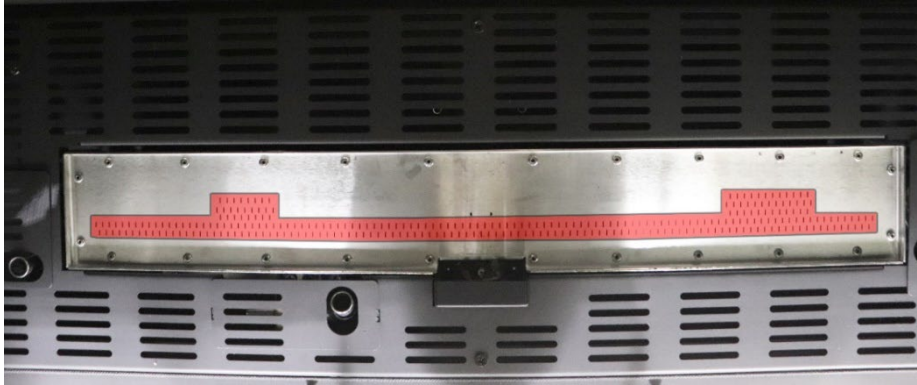

- Placing the log onto the log base/tube:  
**Step 1:** Grasp the log at both ends as shown in the picture.

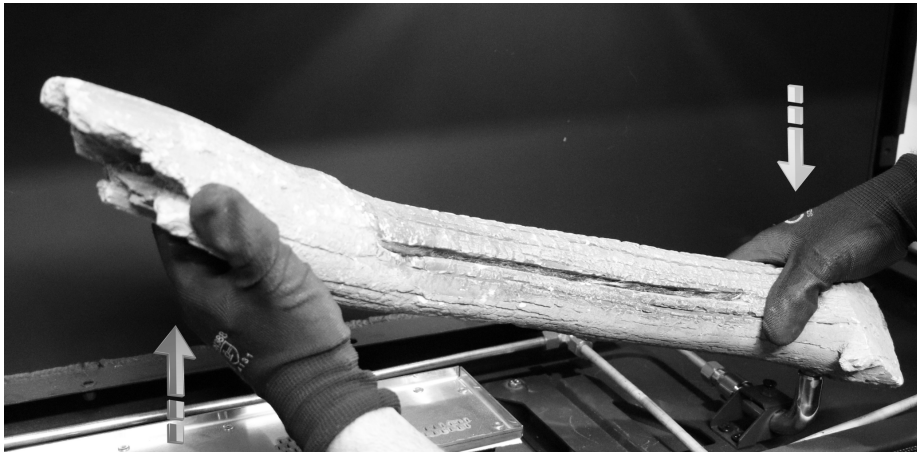

**Step 2:** Insert the tube coming out of the log into its base while making gentle rotational movements back and forth around its axis for easy insertion/removal. See figure below.

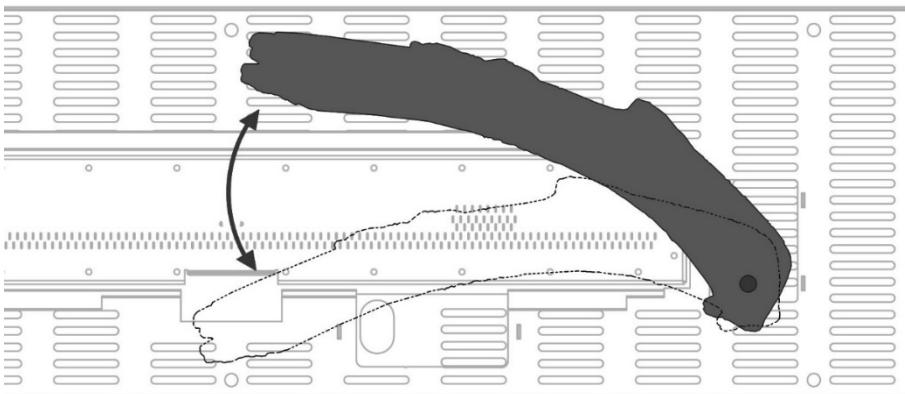

Top View



**WARNING:** Using force when installing the log onto its base/gas tube may result in breakage or damage to the log that will require its replacement.

## Driftwood Firelogs Set

Ortal Driftwood Firelogs are the only interior design media permitted in the Wilderness Traditional series fireplaces. No other interior design media options are permitted. The following Ortal firelog sets are permitted for use in the Wilderness Traditional series fireplaces.

### DRIFTWOOD FIRELOG SETS ARE DIFFERENT FOR NG AND LP:

- Firelog sets for NG and LP have different SKUs. Please ensure you have correct SKU for desired gas type prior to ordering.
- LP logs do not contain nickel strands inside the logs. NG logs do contain nickel strands.

**!** NOTE: It can take up to 20 minutes for the flames to turn yellow.

**!** WARNING: The fireplace is not designed to burn real wood. Any attempt to do so could cause irreparable damage to the fireplace and may result in property damage, personal injury and/or loss of life.

The following items are included with the Driftwood Firelog set for the Wilderness Traditional 36 & 42 fireplaces.



Items Supplied with Driftwood Firelogs

**!** WARNING: To prevent log breakage, follow these log instructions carefully. The gas logs MUST be supported by additional logs as directed as they were not designed to support their own weight solely from the gas supply tube

## Driftwood Firelog Setup for Traditional 36

Log placement of the Driftwood Firelog Set is crucial for optimal fireplace operation and safety purposes. Logs must be arranged as detailed in the following pages. No other arrangement is permitted. Alternative log arrangement will affect fireplace safety, operation, and performance. Handle logs gently to avoid paint damage. Log placement is the same for NG and LP.

### STEP 1: Nickle Strands

1. Use your fingers to separate the nickel strands (supplied 2x20" long) as shown in the image below. It is recommended to cut the nickel strips into 10 equal strips to make it easier to separate them.



Left: Nickel strands as supplied | Right: Nickel strands ready to use

2. Place nickel strands on top of the burner holes. Keep nickel strands a minimum of 1 inch from the pilot.



**⚠ WARNING:** For safety and optimal fireplace function, keep 1 inch around the pilot (behind pilot hood) completely clear of any media or debris.

Arrange firelogs as shown in Steps 2-8.

**STEP 2**

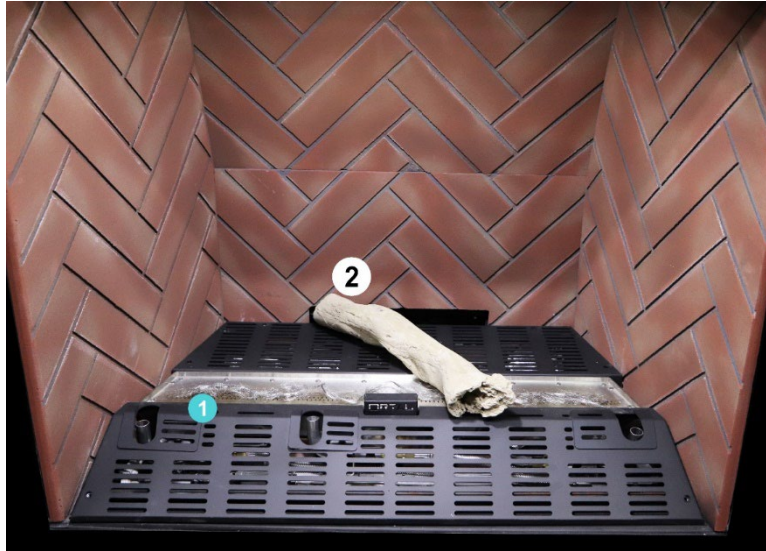

**STEP 3**



The base/tube for log #3 can be adjusted to fit the position shown in the picture above. (See "Log Base position Adjustment" section for details).

**STEP 4**

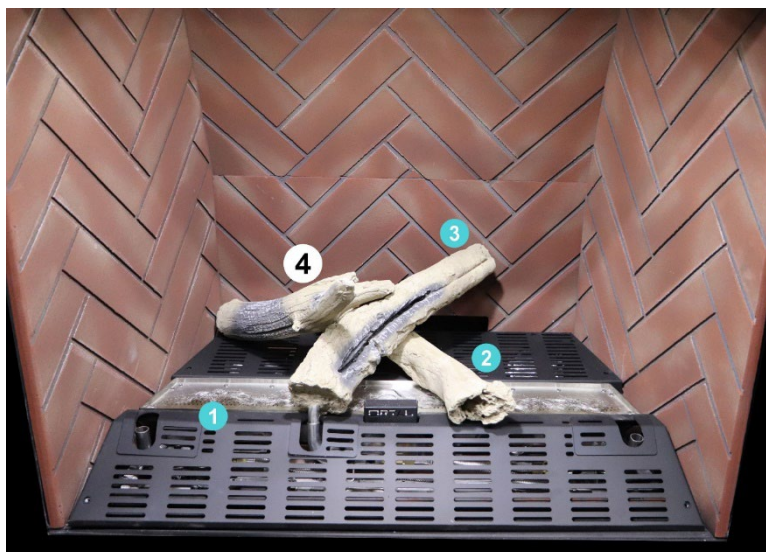

## STEP 5

---



The base/tube for log #5 can be adjusted to fit the position shown in the picture above. (See “Log Base position Adjustment” section for details).

## STEP 6

---

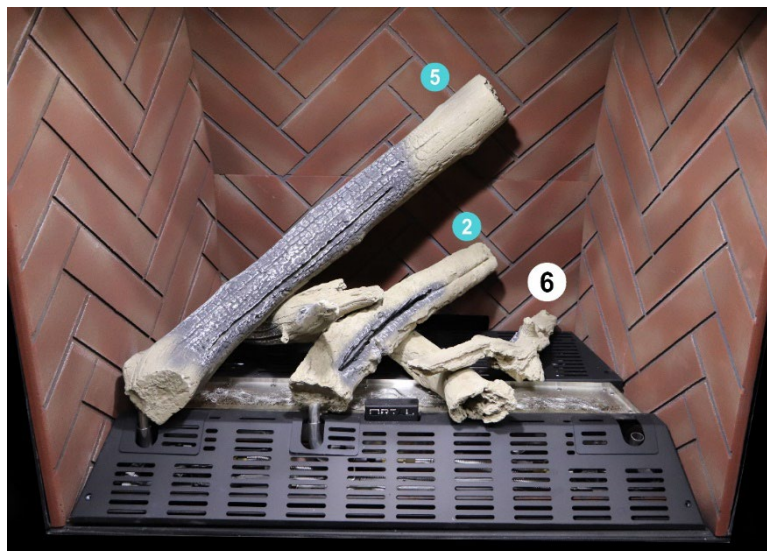

## STEP 7

---



The base/tube for log #7 can be adjusted to fit the position shown in the picture below (see “Log Base Position Adjustment” section for details).

## STEP 8



## STEP 9: Charcoal

Add charcoal pieces to the remainder of the burner. **Do not cover any burner holes.** Maintain minimum 1-inch clearance around the pilot behind pilot hood.



**⚠ WARNING:** For safety and optimal fireplace function, keep 1 inch around the pilot (behind pilot hood) completely clear of any media or debris.

**⚠ WARNING:** To prevent log breakage, follow these log instructions carefully. The gas logs ***MUST*** be supported by additional logs as directed as they were not designed to support their own weight solely from the gas supply tube.

## Driftwood Firelog Setup for Traditional 42

Log placement of the Driftwood Firelog Set is crucial for optimal fireplace operation and safety purposes. Logs must be arranged as detailed in the following pages. No other arrangement is permitted. Alternative log arrangement will affect fireplace safety, operation, and performance. Handle logs gently to avoid paint damage. Log placement is the same for NG and LP.

### STEP 1: Nickle Strands

1. Use your fingers to separate the nickle strands (supplied 2x20" long) as shown in the image below. It is recommended to cut the nickle strips into 10 equal strips to make it easier to separate them.



Left: Nickel strands as supplied | Right: Nickel strands ready to use

2. Place nickel strands on top of the burner holes. Keep nickel strands a minimum of 1 inch from the pilot.



**⚠ WARNING:** For safety and optimal fireplace function, keep 1 inch around the pilot (behind pilot hood) completely clear of any media or debris.

Arrange firelogs as shown in Steps 2-8.

### STEP 2



### STEP 3

---

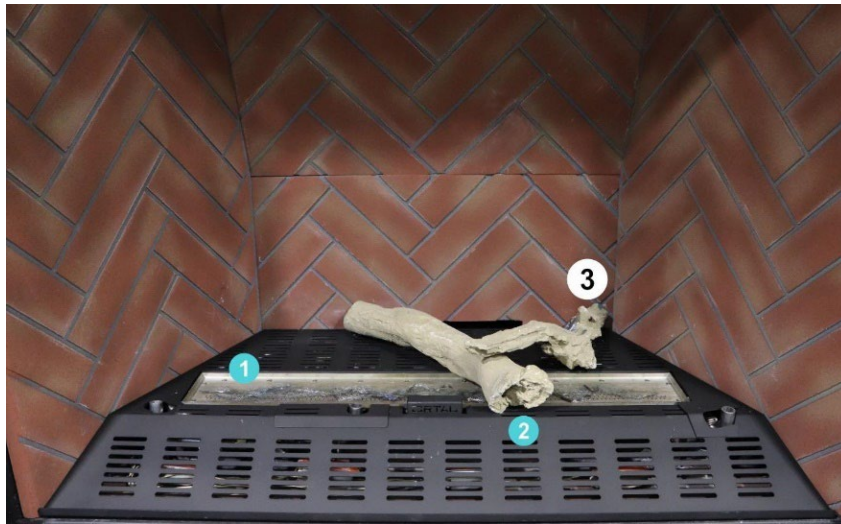

### STEP 4

---



The tube for log #4 can be adjusted to fit the position shown in the picture above (see “Log Base Position Adjustment” section for details).

### STEP 5

---

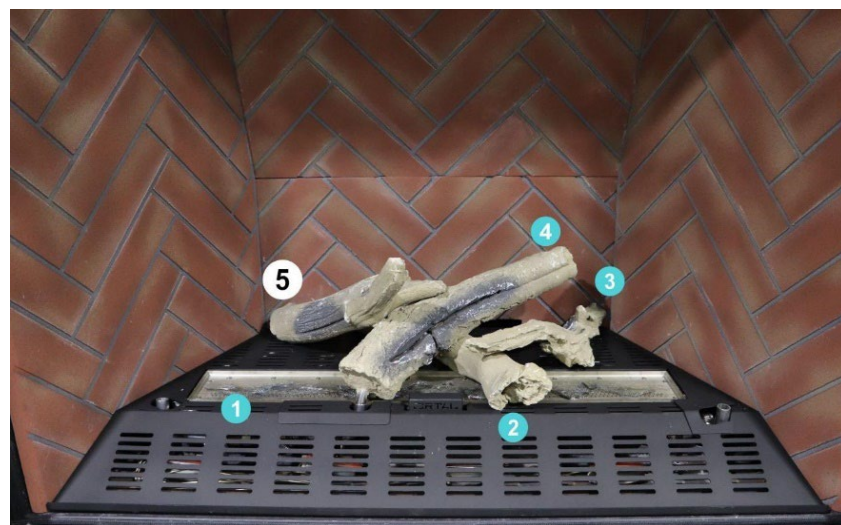

## STEP 6

---

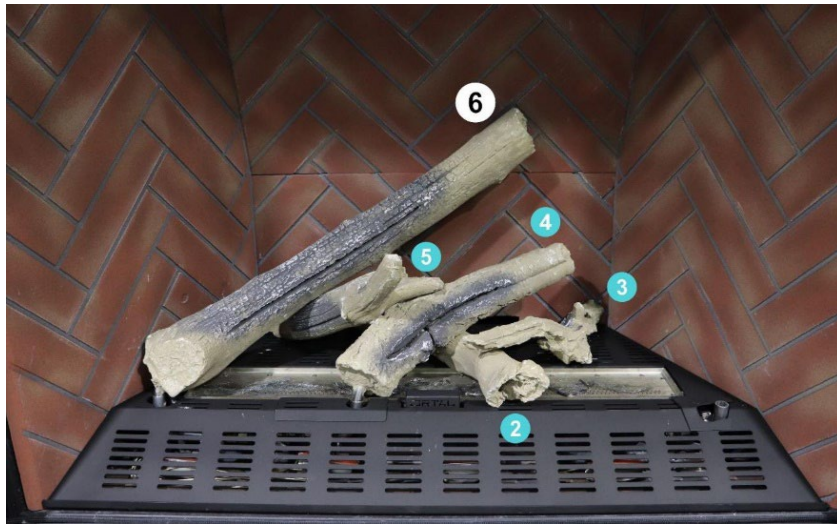

The base/tube for log #6 can be adjusted to fit the position shown in the picture below (see “Log Base Position Adjustment” section for details).

## STEP 7

---

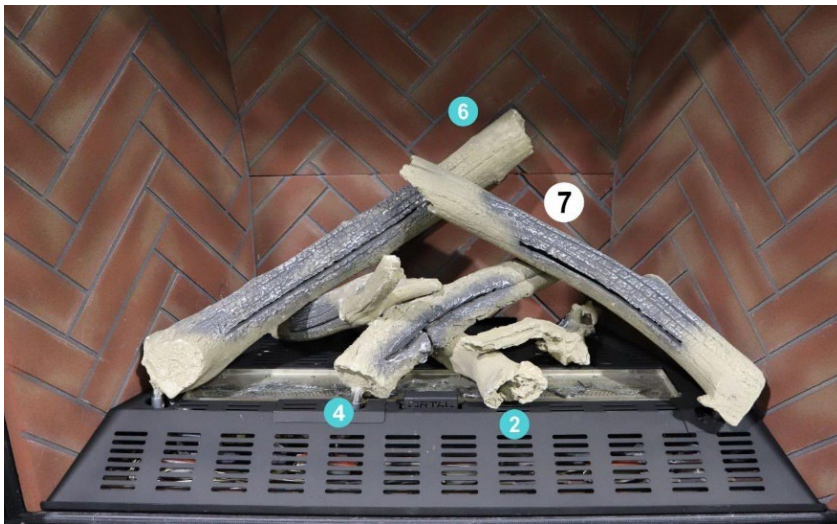

The base/tube for log #7 can be adjusted to fit the position shown in the picture below (see “Log Base Position Adjustment” section for details).

## STEP 8

---

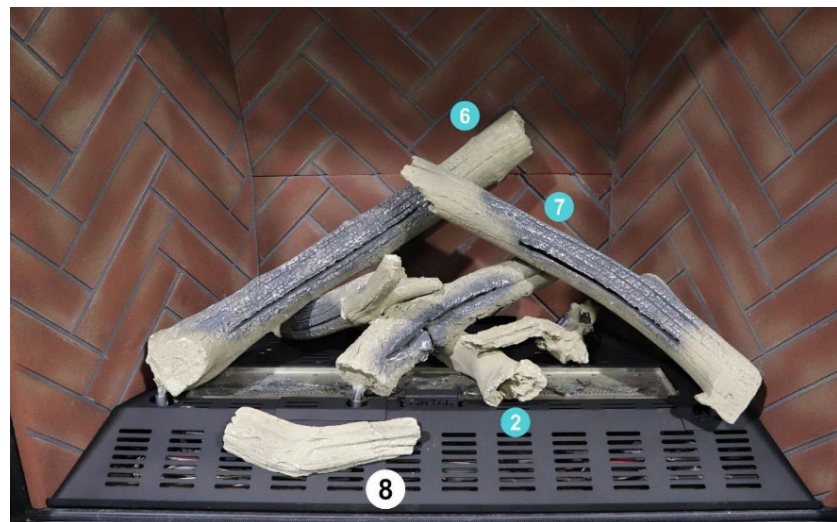

## STEP 9: Charcoal

Add charcoal pieces to the remainder of the burner. **Do not cover any burner holes.** Maintain minimum 1-inch clearance around the pilot behind pilot hood.

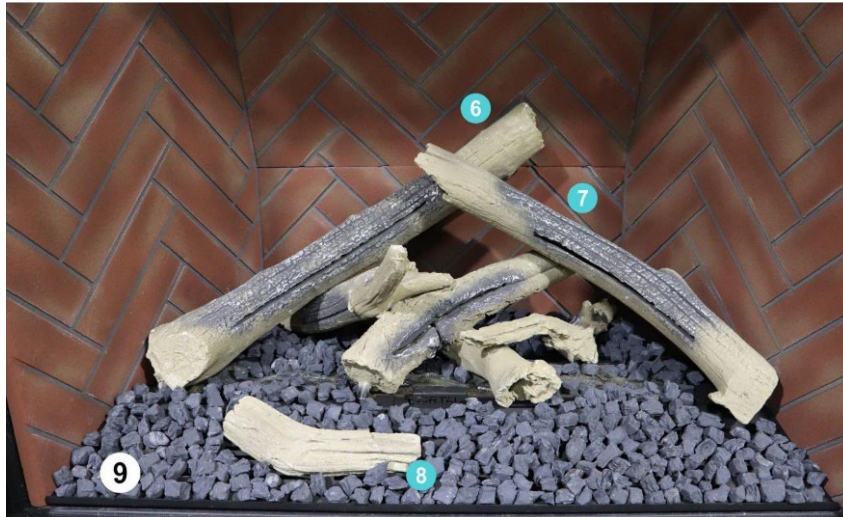

**⚠ WARNING:** For safety and optimal fireplace function, keep 1 inch around the pilot (behind pilot hood) completely clear of any media or debris.

**⚠ WARNING:** To prevent log breakage, follow these log instructions carefully. The gas logs ***MUST*** be supported by additional logs as directed as they were not designed to support their own weight solely from the gas supply tube.

## Valley Oak Firelog Set

Ortal Valley Oak Firelogs are the only interior design media permitted in the Wilderness Traditional series fireplaces. No other interior design media options are permitted. The following Ortal firelog sets are permitted for use in the Wilderness Traditional series fireplaces.

### VALLEY OAK FIRELOG SETS ARE DIFFERENT FOR NG AND LP:

- Firelog sets for NG and LP have different SKUs. Please ensure you have correct SKU for desired gas type prior to ordering.
- LP logs do not contain nickel strands inside the logs. NG logs do contain nickel strands.

**!** NOTE: It can take up to 20 minutes for the flames to turn yellow.

**!** WARNING: The fireplace is not designed to burn real wood. Any attempt to do so could cause irreparable damage to the fireplace and may result in property damage, personal injury and/or loss of life.

The following items are included with the Valley Oak Firelog set for the Wilderness Traditional 36 & 42 fireplaces.



Nickel strands



Black coals

## Valley Oak Firelog Setup for Traditional 36

Log placement of the Valley Oak Firelog Set is crucial for optimal fireplace operation and safety purposes. Logs must be arranged as detailed in the following pages. No other arrangement is permitted. Alternative log arrangement will affect fireplace safety, operation, and performance. Handle logs gently to avoid paint damage. Log placement is the same for NG and LP.

### STEP 1: Nickle Strands

1. Use your fingers to separate the nickle strands (supplied 2x20" long) as shown in the image below. It is recommended to cut the nickle strips into 10 equal strips to make it easier to separate them.



Left: Nickel strands as supplied | Right: Nickel strands ready to use

2. Place nickel strands on top of the burner holes. Keep nickel strands a minimum of 1 inch from the pilot.

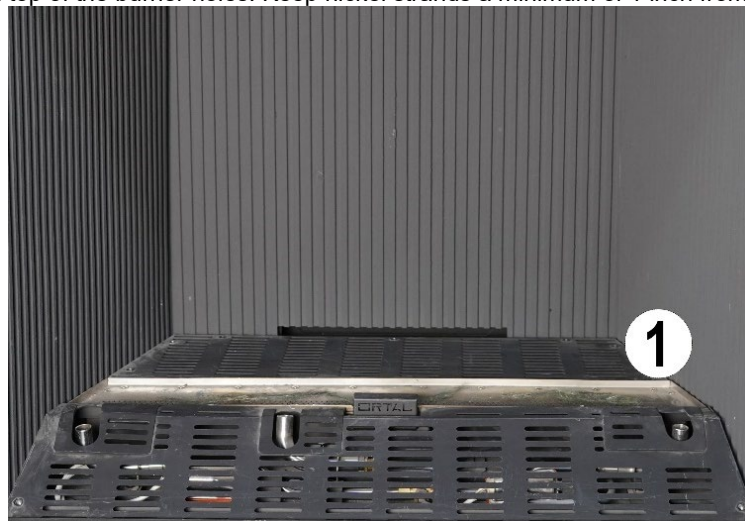

**⚠ WARNING:** For safety and optimal fireplace function, keep 1 inch around the pilot (behind pilot hood) completely clear of any media or debris.

Arrange firelogs as shown in Steps 2-10.

**STEP 2**

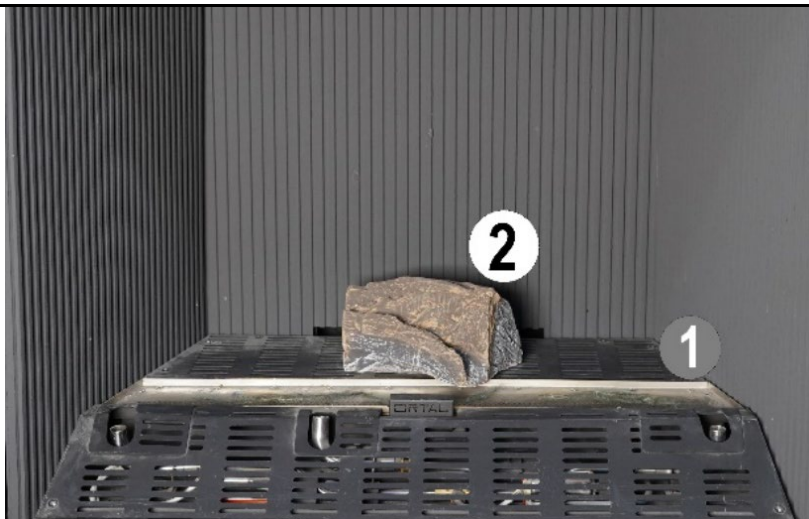

**STEP 3**

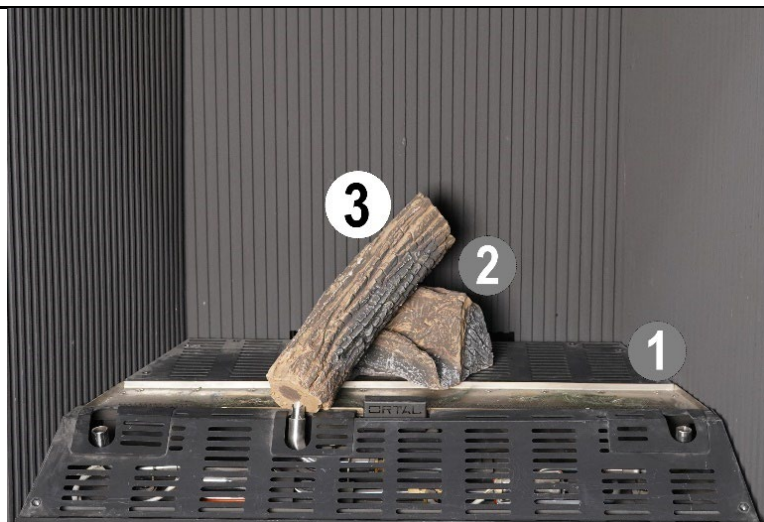

The base for log #3 can be adjusted to fit the position in the picture above. (See "Log Base position Adjustment" section for details).

**STEP 4**

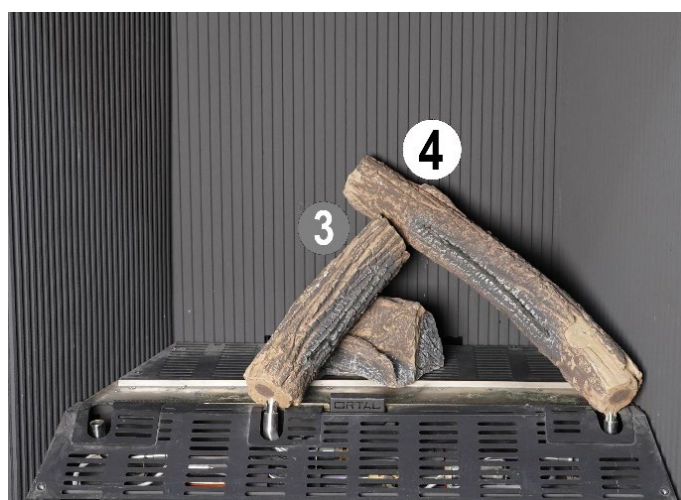

The base for log #4 can be adjusted to fit the position in the picture above. (See "Log Base position Adjustment" section for details).

## STEP 5

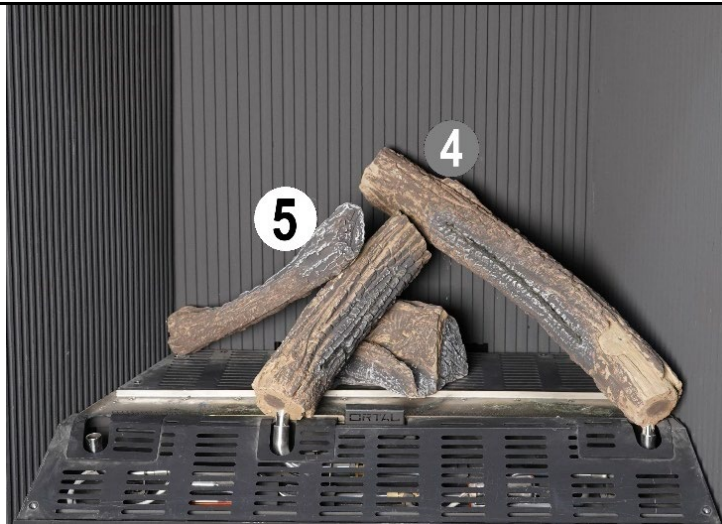

## STEP 6



The base for log #6 can be adjusted to fit the position in the picture above. (See “Log Base position Adjustment” section for details).

## STEP 7



## STEP 8

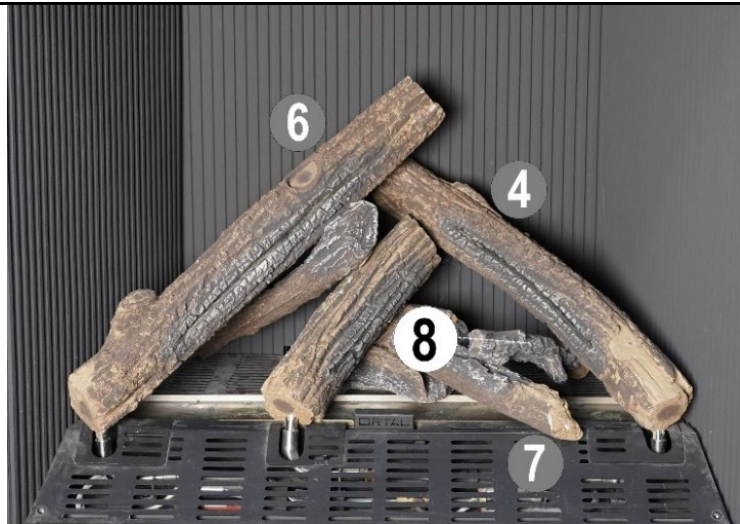

## STEP 9



## STEP 10



## STEP 11

Add charcoal pieces to the remainder of the burner. **Do not cover any burner holes.** Maintain minimum 1-inch clearance around the pilot behind pilot hood.



**⚠ WARNING:** For safety and optimal fireplace function, keep 1 inch around the pilot (behind pilot hood) completely clear of any media or debris.

**⚠ WARNING:** To prevent log breakage, follow these log instructions carefully. The gas logs **MUST** be supported by additional logs as directed as they were not designed to support their own weight solely from the gas supply tube.

## Valley Oak Firelog Setup for Traditional 42

Log placement of the Driftwood Firelog Set is crucial for optimal fireplace operation and safety purposes. Logs must be arranged as detailed in the following pages. No other arrangement is permitted. Alternative log arrangement will affect fireplace safety, operation, and performance. Handle logs gently to avoid paint damage. Log placement is the same for NG and LP.

### STEP 1: Nickle Strands

1. Use your fingers to separate the nickle strands (supplied 2x20" long) as shown in the image below. It is recommended to cut the nickle strips into 10 equal strips to make it easier to separate them.



Left: Nickle strands as supplied | Right: Nickle strands ready to use

2. Place nickle strands on top of the burner holes. Keep nickle strands a minimum of 1 inch from the pilot.



**⚠ WARNING:** For safety and optimal fireplace function, keep 1 inch around the pilot (behind pilot hood) completely clear of any media or debris.

**Arrange firelogs as shown in Steps 2-10.**

## STEP 2

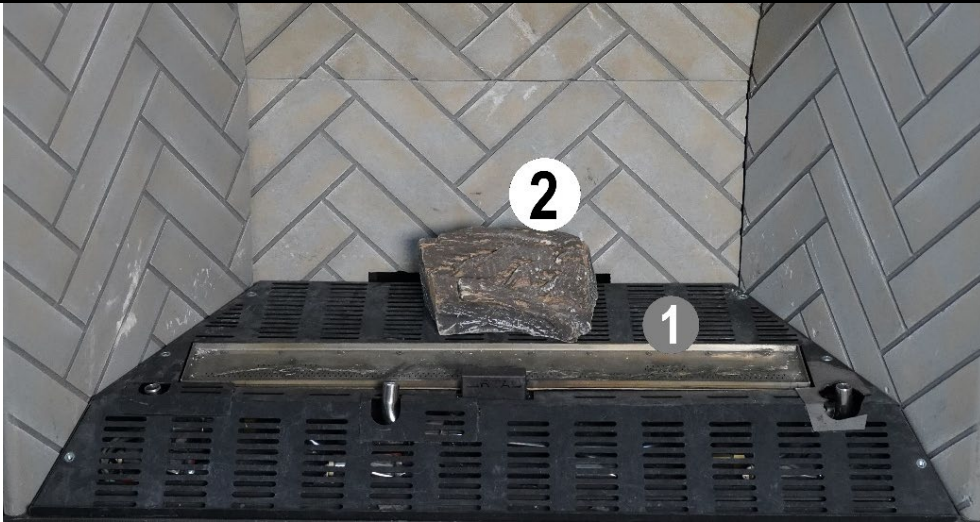

## STEP 3



## STEP 4

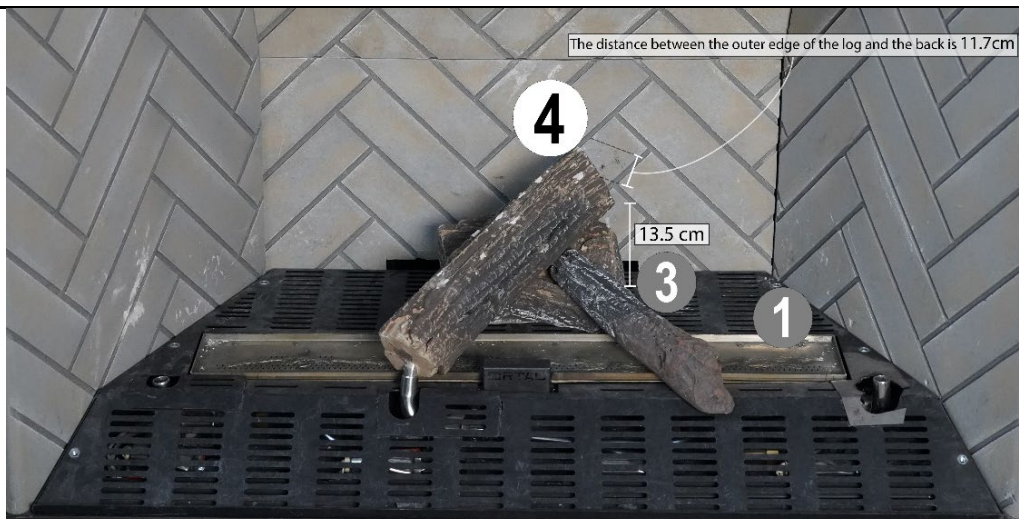

The base/tube for log #4 can be adjusted to fit the position shown in the picture above. (See "Log Base position Adjustment" section for details). The distance between the outer edge of the log and the back is 11.7 cm.

## STEP 5

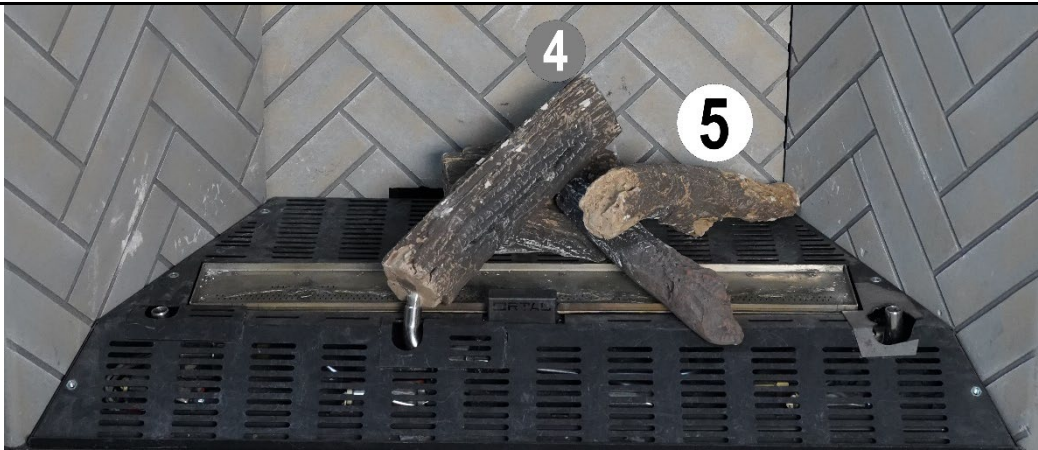

## STEP 6



## STEP 7

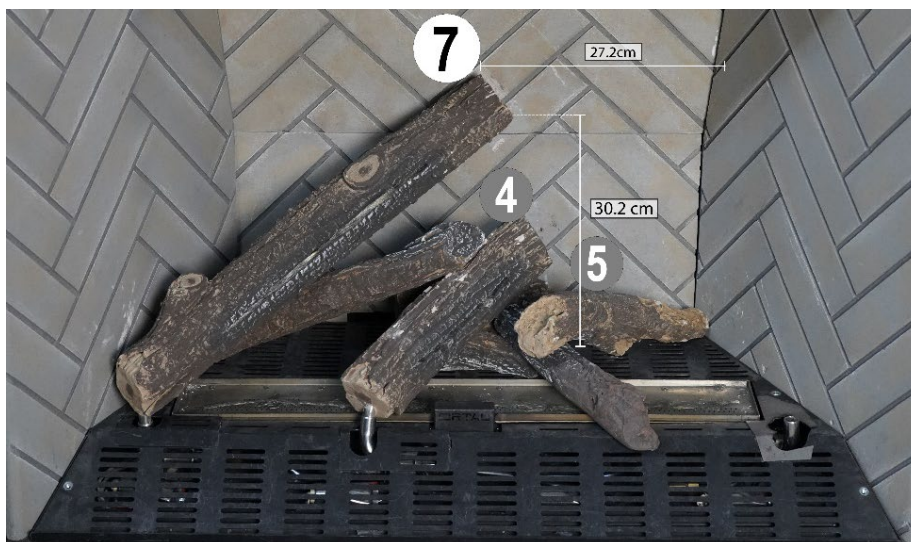

The base/tube for log #7 can be adjusted to fit the position shown in the picture above. (See “Log Base position Adjustment” section for details). Log #7 is 27.2cm from the right-side refractory and 30.2cm from the media tray.

## STEP 8

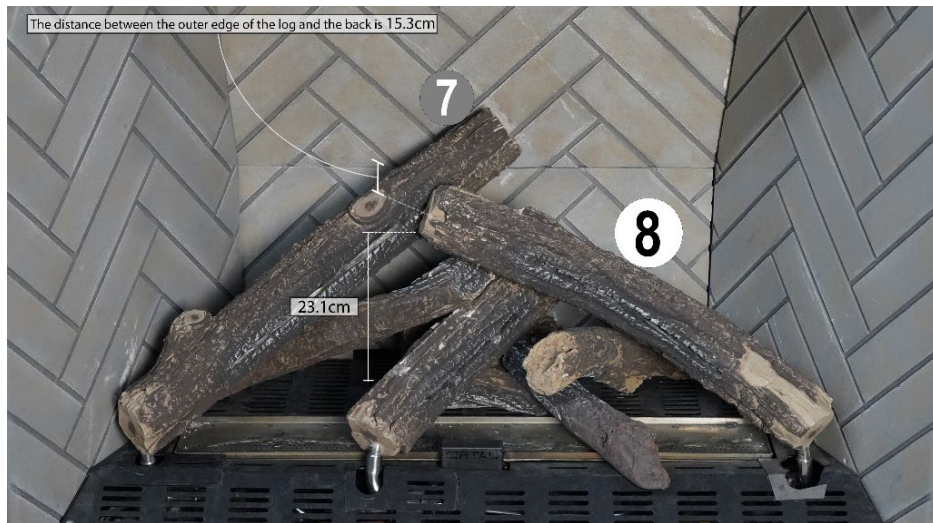

The base/tube for log #8 can be adjusted to fit the position shown in the picture above. (See "Log Base position Adjustment" section for details). The distance between the outer edge of the log and the back is 15.3cm.

## STEP 9

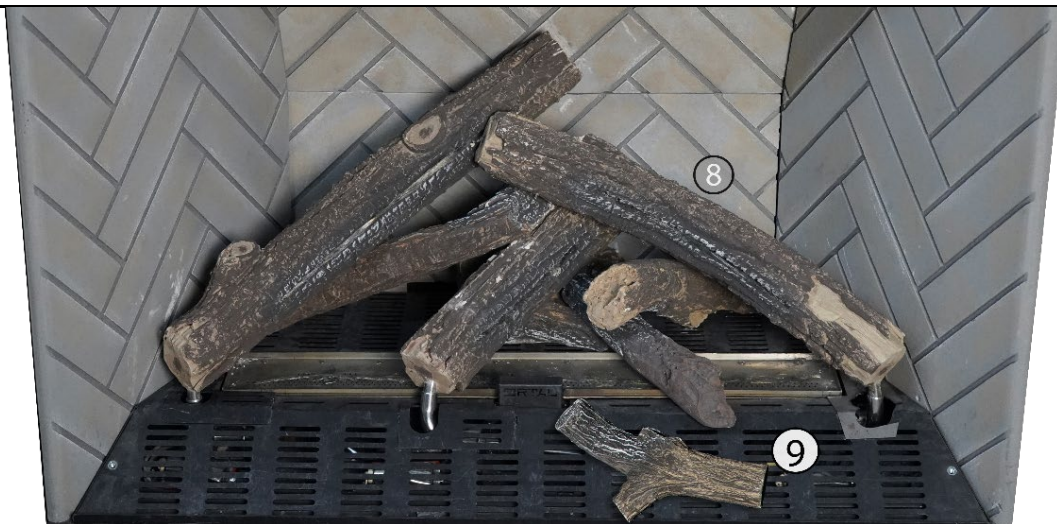

## STEP 10



## STEP 11

Add charcoal pieces to the remainder of the burner. **Do not cover any burner holes.** Maintain minimum 1-inch clearance around the pilot behind pilot hood.



**⚠ WARNING:** For safety and optimal fireplace function, keep 1 inch around the pilot (behind pilot hood) completely clear of any media or debris.

**⚠ WARNING:** To prevent log breakage, follow these log instructions carefully. The gas logs ***MUST*** be supported by additional logs as directed as they were not designed to support their own weight solely from the gas supply tube.

## Birch Firelog Set

Ortal Birch Firelogs are the only interior design media permitted in the Wilderness Traditional series fireplaces. No other interior design media options are permitted. The following Ortal firelog sets are permitted for use in the Wilderness Traditional series fireplaces.

### BIRCH FIRELOG SETS ARE DIFFERENT FOR NG AND LP:

- Firelog sets for NG and LP have different SKUs. Please ensure you have correct SKU for desired gas type prior to ordering.
- LP logs do not contain nickel strands inside the logs. NG logs do contain nickel strands.

**!** NOTE: It can take up to 20 minutes for the flames to turn yellow.

**!** WARNING: The fireplace is not designed to burn real wood. Any attempt to do so could cause irreparable damage to the fireplace and may result in property damage, personal injury and/or loss of life.

The following items are included with the Birch Firelog set for the Wilderness Traditional 36 fireplaces:

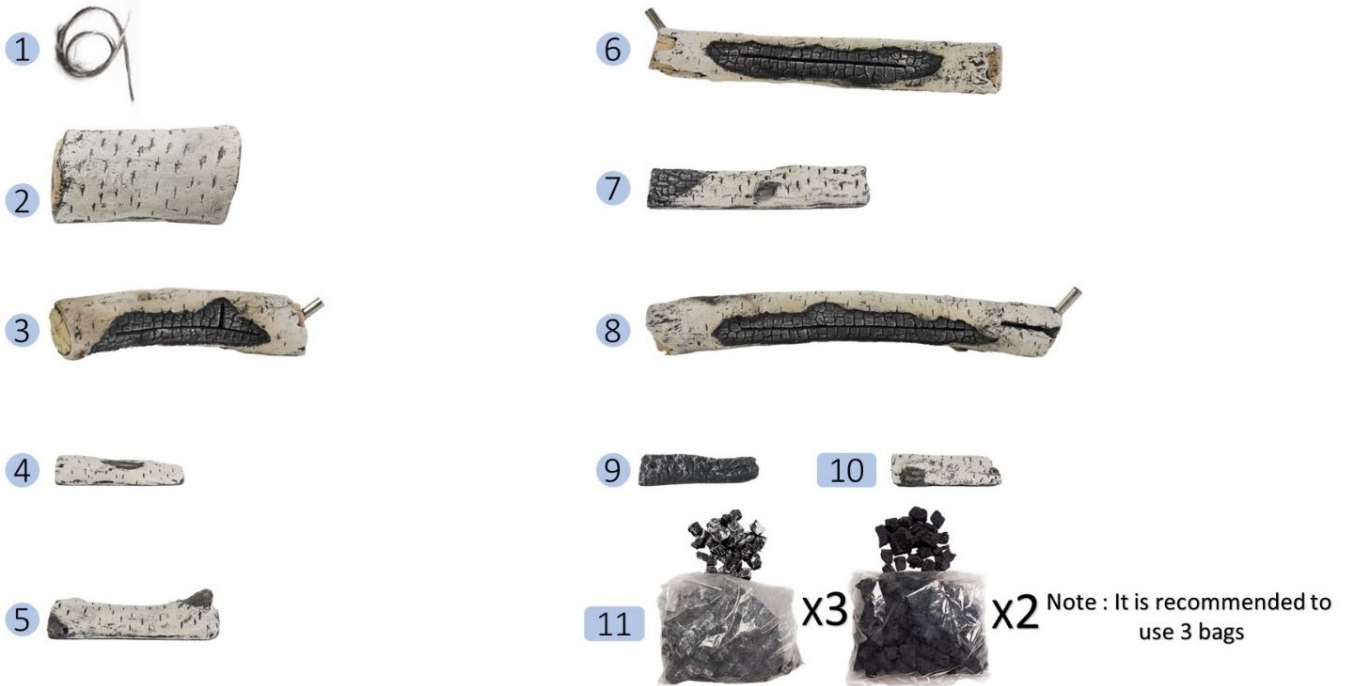

The following items are included with the Birch Firelog set for the Wilderness Traditional 42 fireplaces:

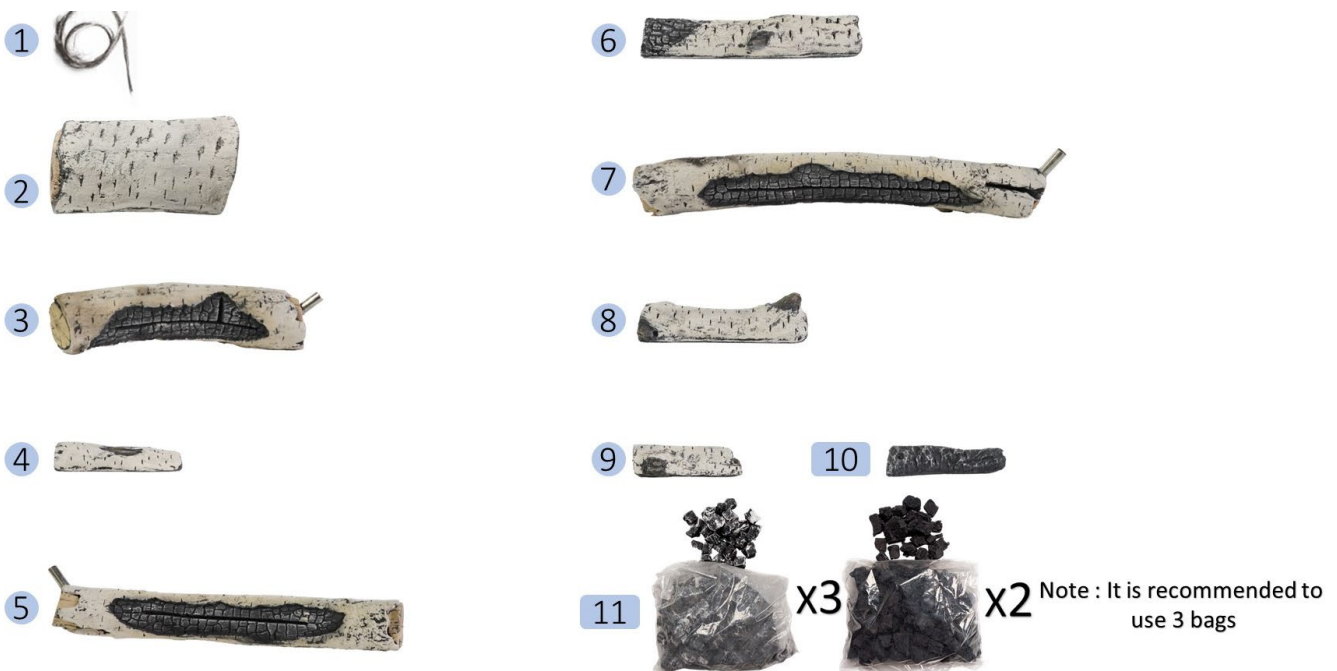

## Birch Firelog Setup for Traditional 36

Log placement of the Birch Firelog Set is crucial for optimal fireplace operation and safety purposes. Logs must be arranged as detailed in the following pages. No other arrangement is permitted. Alternative log arrangement will affect fireplace safety, operation, and performance. Handle logs gently to avoid paint damage. Log placement is the same for NG and LP.

### STEP 1: Nickle Strands

1. Use your fingers to separate the nickle strands (supplied 2x20" long) as shown in the image below. It is recommended to cut the nickle strips into 10 equal strips to make it easier to separate them.



Left: Nickel strands as supplied | Right: Nickel strands ready to use

2. Place nickel strands on top of the burner holes. Keep nickel strands a minimum of 1 inch from the pilot.

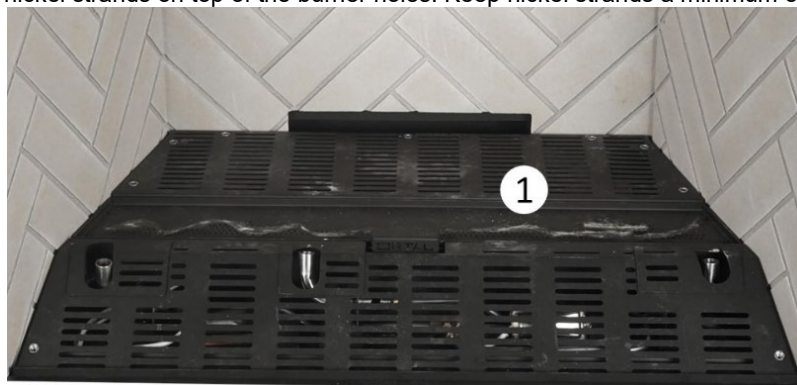

**⚠ WARNING:** For safety and optimal fireplace function, keep 1 inch around the pilot (behind pilot hood) completely clear of any media or debris.

Arrange firelogs as shown in Steps 2-10.

### STEP 2

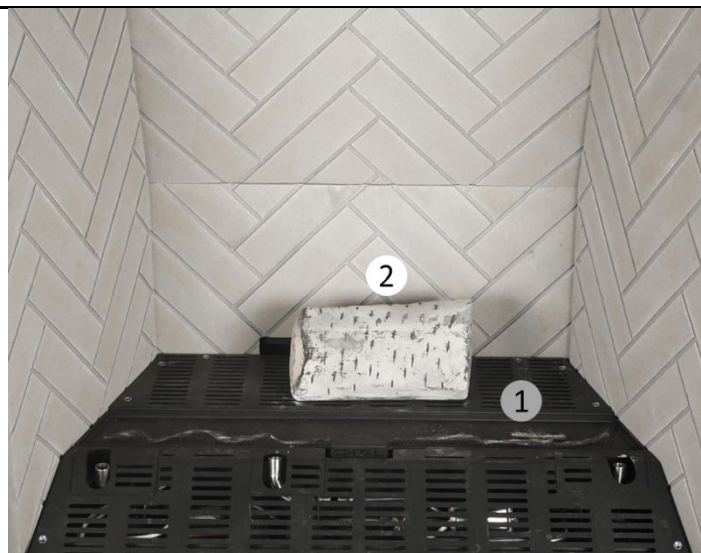

### STEP 3

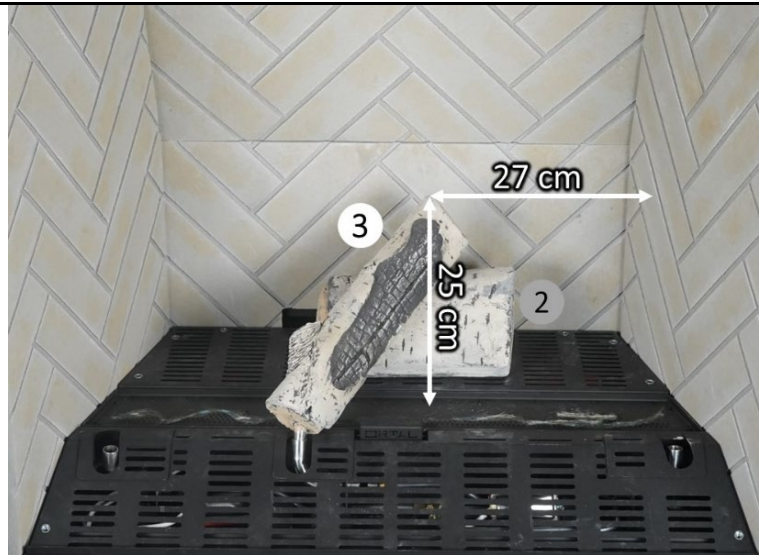

The base for log #3 can be adjusted to fit the position in the picture above. (See “Log Base position Adjustment” section for details).

### STEP 4



### STEP 5



## STEP 6

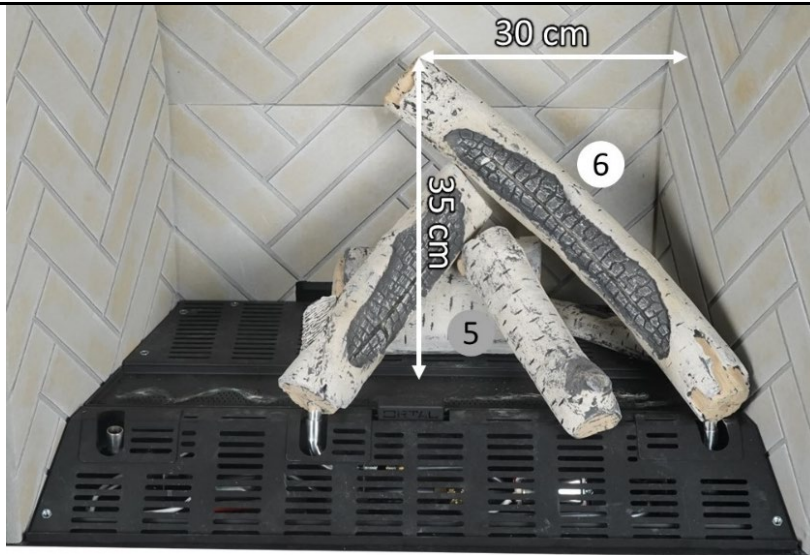

The base for log #6 can be adjusted to fit the position in the picture above. (See “Log Base position Adjustment” section for details).

## STEP 7



## STEP 8

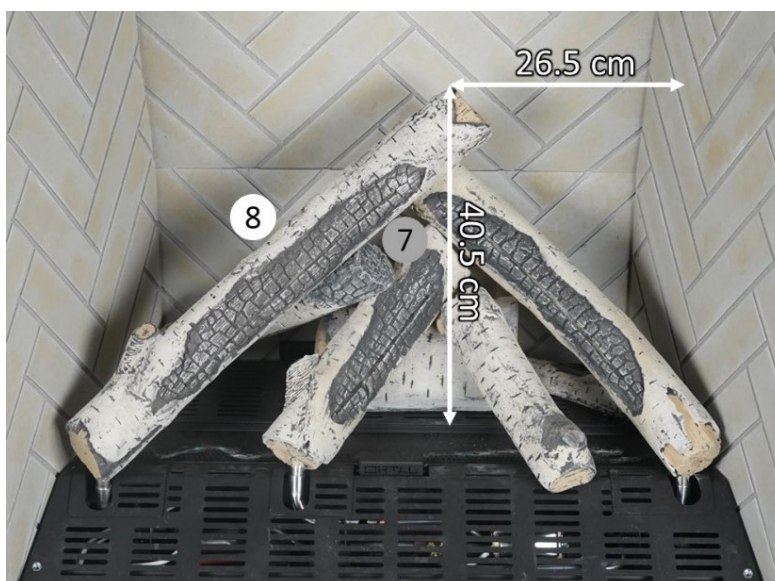

The base for log #8 can be adjusted to fit the position in the picture above. (See “Log Base position Adjustment” section for details).

## STEP 9

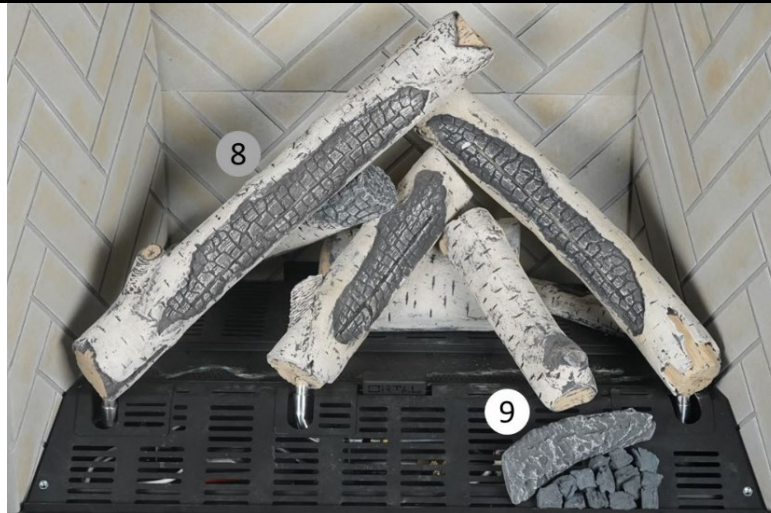

## STEP 10

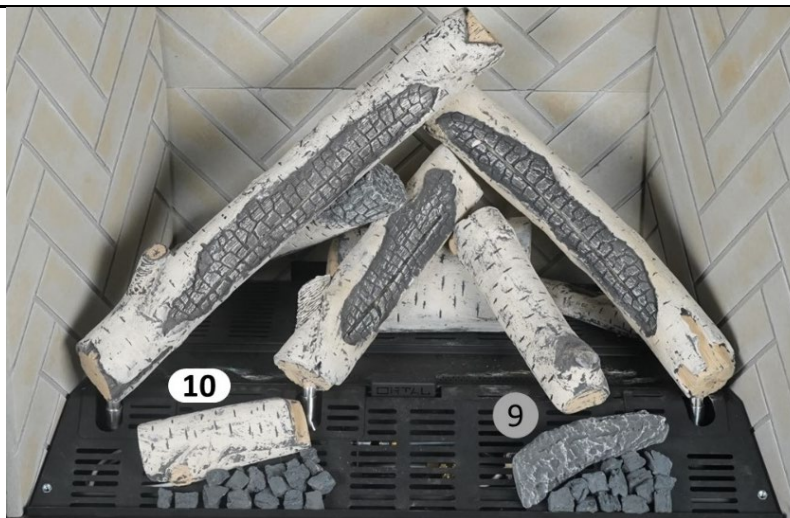

## STEP 11

Add charcoal pieces to the remainder of the burner. **Do not cover any burner holes.** Maintain minimum 1-inch clearance around the pilot behind pilot hood.

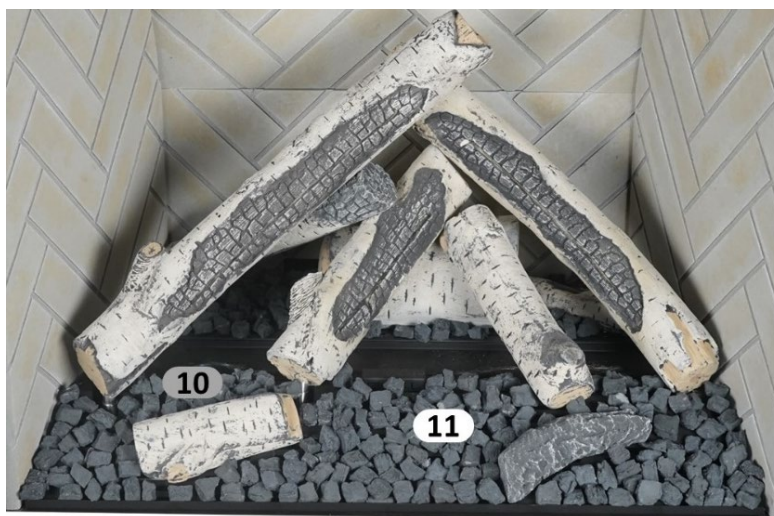

**⚠ WARNING:** For safety and optimal fireplace function, keep 1 inch around the pilot (behind pilot hood) completely clear of any media or debris.

**⚠ WARNING:** To prevent log breakage, follow these log instructions carefully. The gas logs ***MUST*** be supported by additional logs as directed as they were not designed to support their own weight solely from the gas supply tube.

## Birch Firelog Setup for Traditional 42

Log placement of the Birch Firelog Set is crucial for optimal fireplace operation and safety purposes. Logs must be arranged as detailed in the following pages. No other arrangement is permitted. Alternative log arrangement will affect fireplace safety, operation, and performance. Handle logs gently to avoid paint damage. Log placement is the same for NG and LP.

### STEP 1: Nickle Strands

3. Use your fingers to separate the nickel strands (supplied 2x20" long) as shown in the image below. It is recommended to cut the nickel strips into 10 equal strips to make it easier to separate them.



Left: Nickel strands as supplied | Right: Nickel strands ready to use

4. Place nickel strands on top of the burner holes. Keep nickel strands a minimum of 1 inch from the pilot.

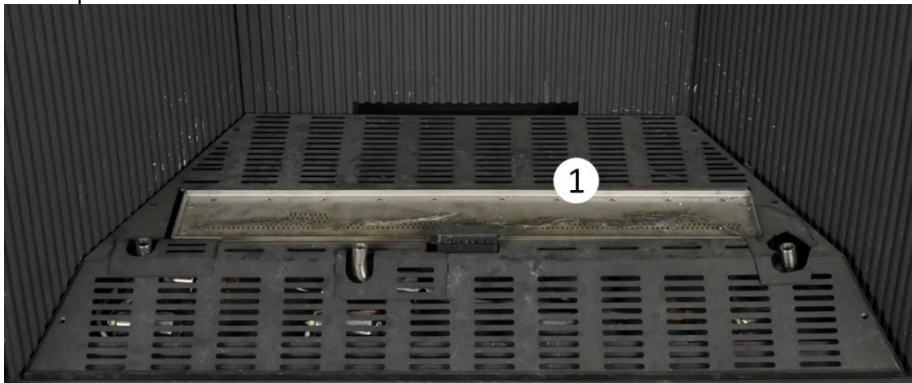

**⚠ WARNING:** For safety and optimal fireplace function, keep 1 inch around the pilot (behind pilot hood) completely clear of any media or debris.

Arrange firelogs as shown in Steps 2-10.

### STEP 2

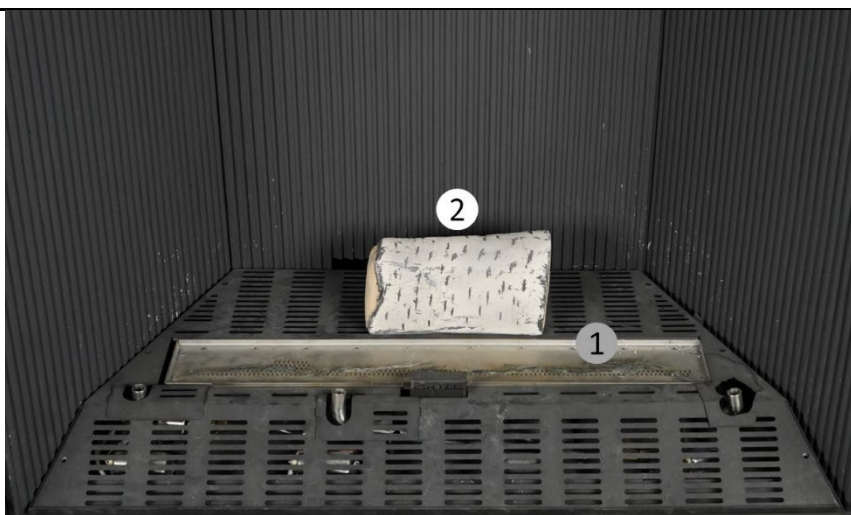

### STEP 3

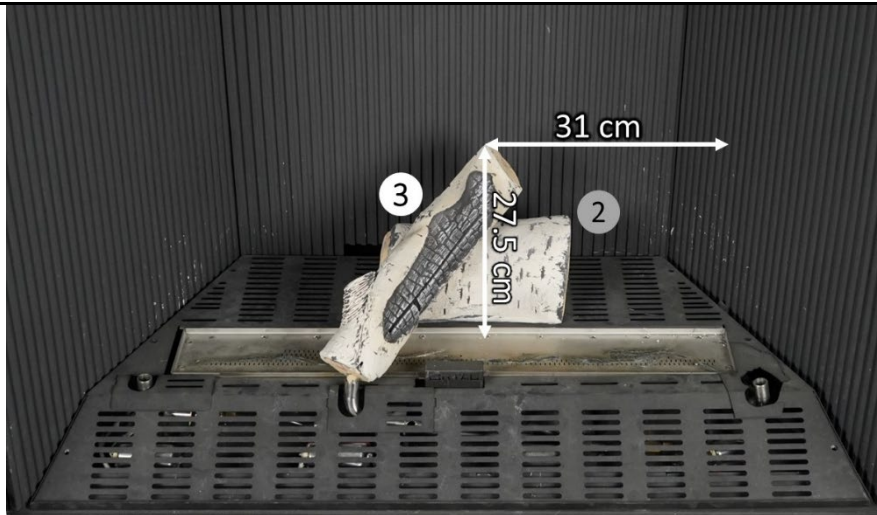

The base for log #3 can be adjusted to fit the position in the picture above. (See “Log Base position Adjustment” section for details).

### STEP 4

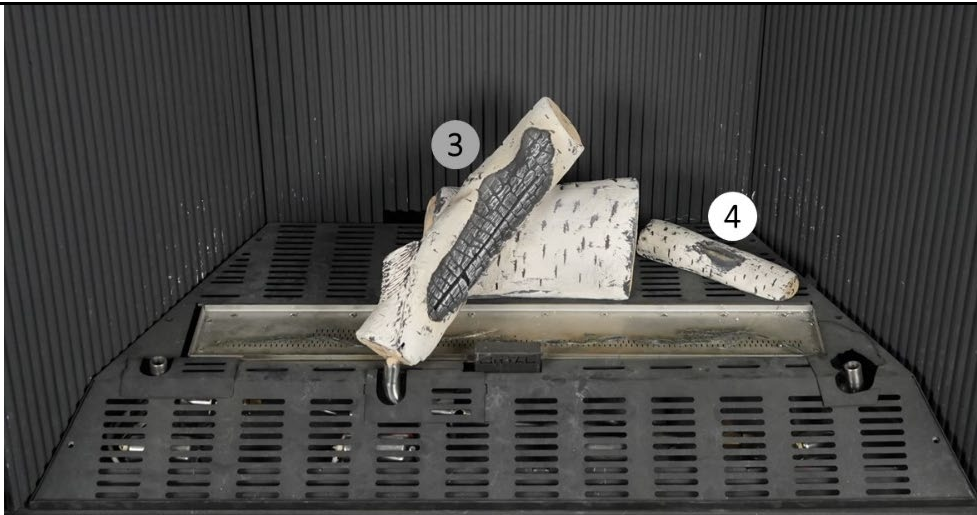

### STEP 5

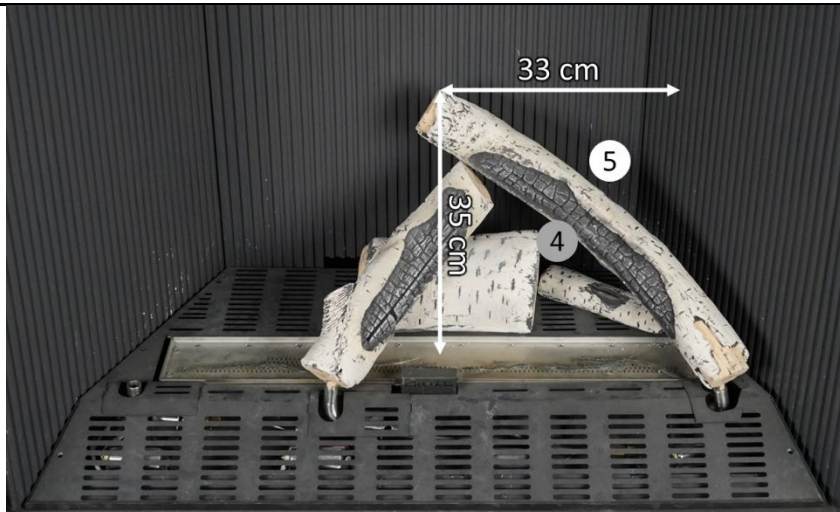

The base for log #5 can be adjusted to fit the position in the picture above. (See “Log Base position Adjustment” section for details).

## STEP 6

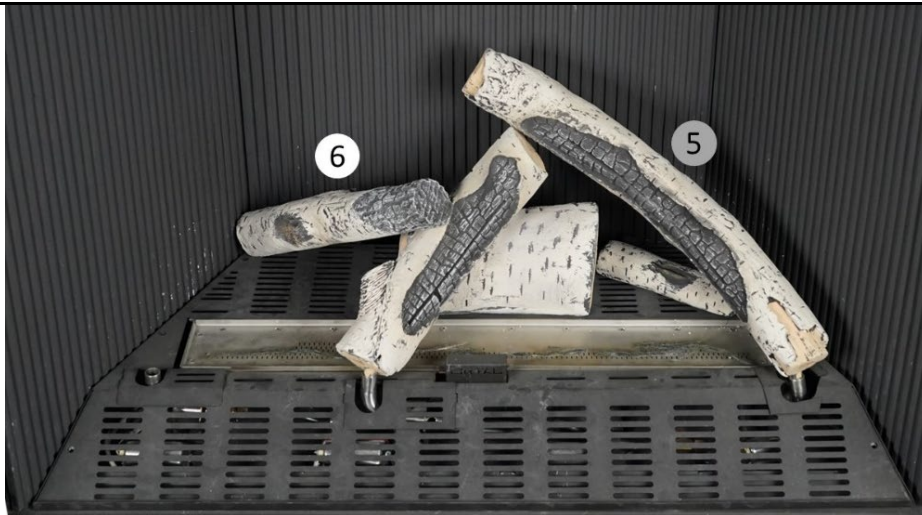

## STEP 7

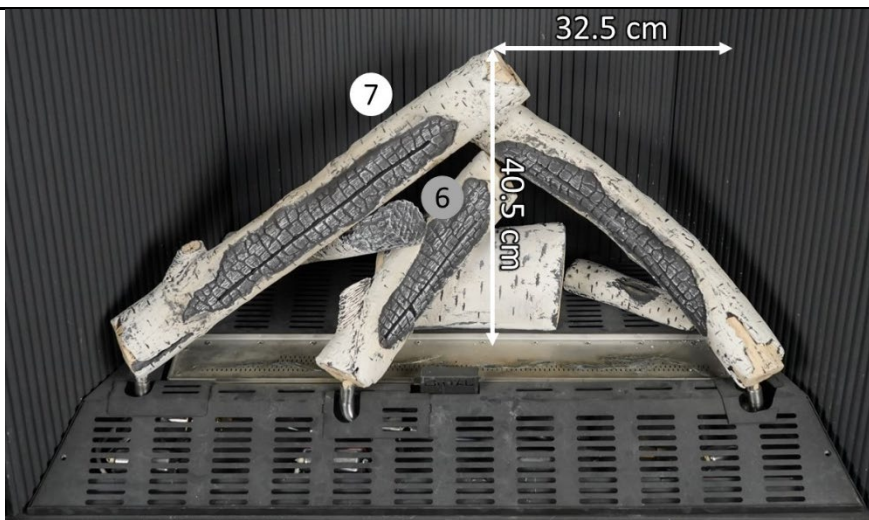

The base for log #7 can be adjusted to fit the position in the picture above. (See “Log Base position Adjustment” section for details).

## STEP 8

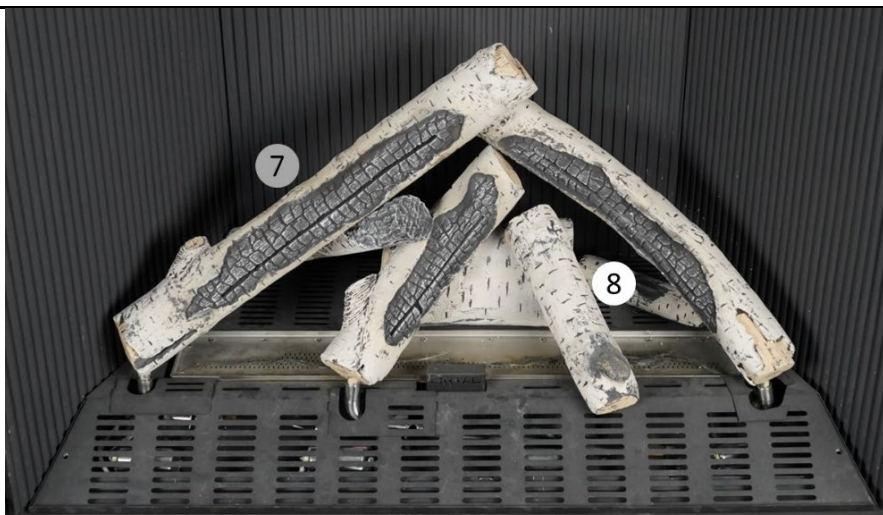

## STEP 9

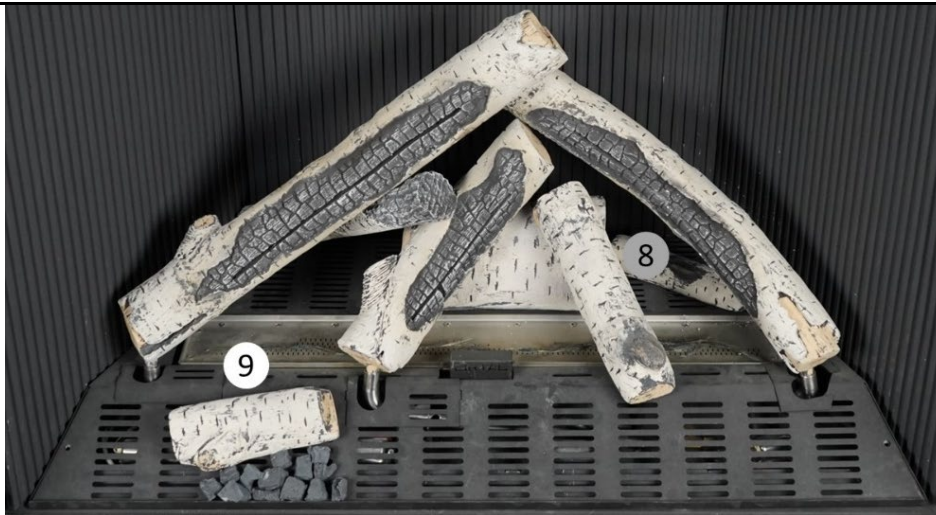

## STEP 10



## STEP 11

Add charcoal pieces to the remainder of the burner. **Do not cover any burner holes.** Maintain minimum 1-inch clearance around the pilot behind pilot hood.

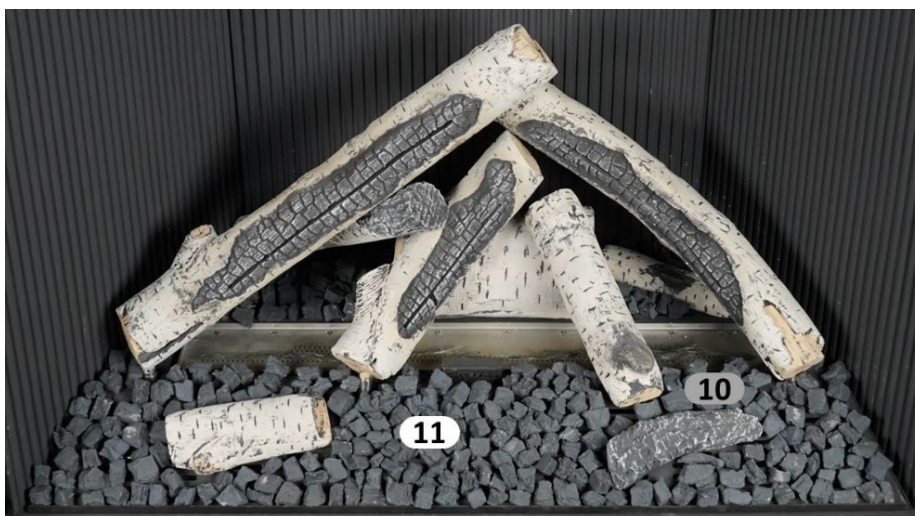

**⚠ WARNING:** For safety and optimal fireplace function, keep 1 inch around the pilot (behind pilot hood) completely clear of any media or debris.

**⚠ WARNING:** To prevent log breakage, follow these log instructions carefully. The gas logs ***MUST*** be supported by additional logs as directed as they were not designed to support their own weight solely from the gas supply tube.

## Log Base/Tube Position Adjustment

### Adjustment Instructions

**!** NOTE: The following images show a generic fireplace for illustrative purposes only.

#### **Step 1**

Remove heat barrier and inner glass panel.

#### **Step 2**

Remove each log by pulling log up at the base, as shown in figure (1).

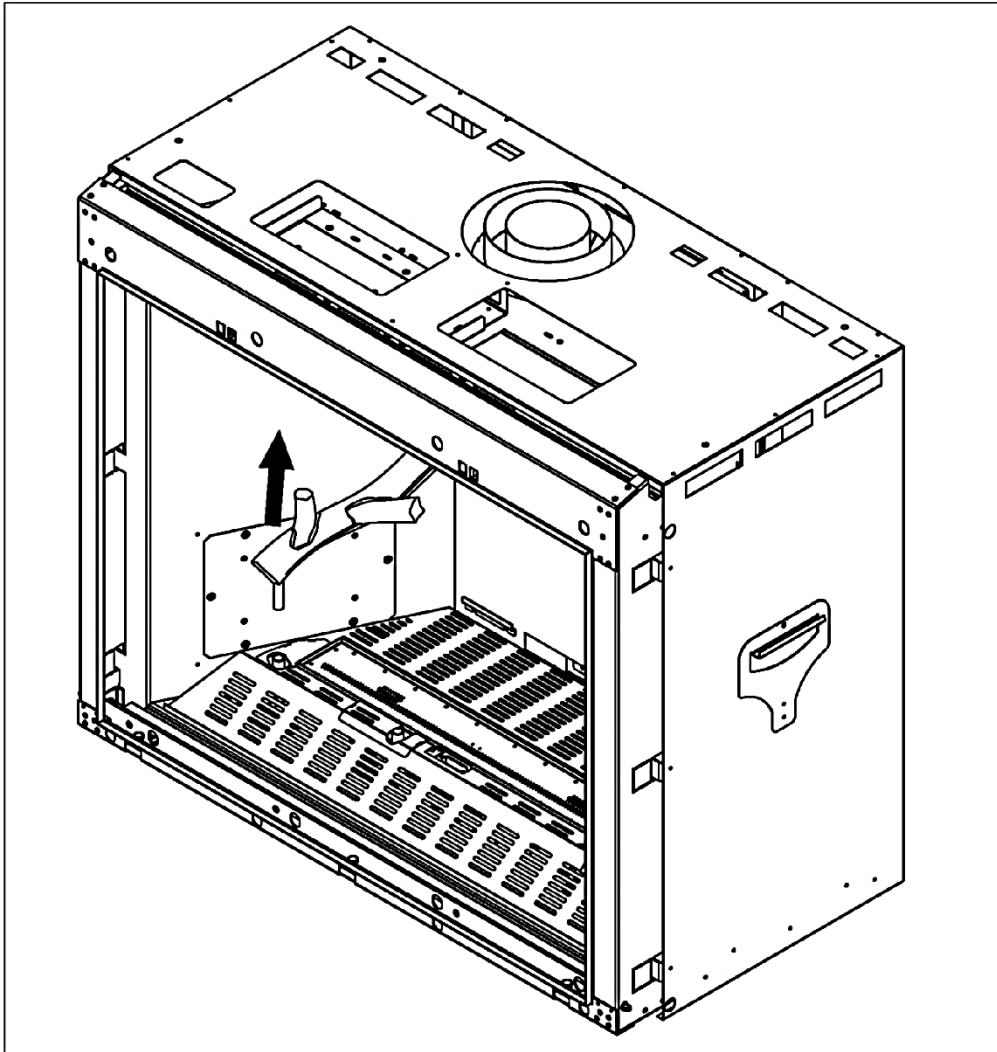

Figure(1)

**Step 3**

Remove left, center, and right grille covers, as shown in figure (2).

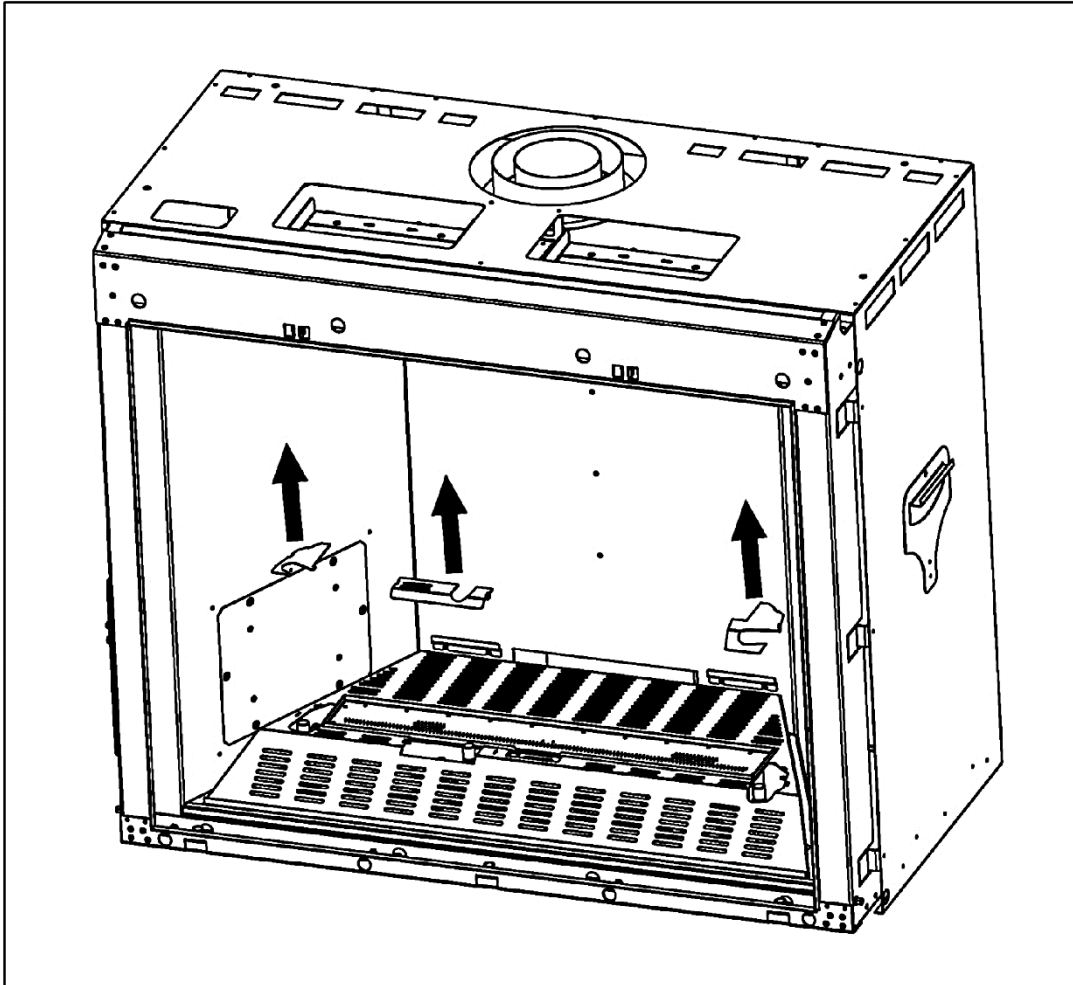

Figure(2)

### **Step 4**

Using a Phillips head screwdriver, loosen the screw on top of the log tube, as shown in figure (3)

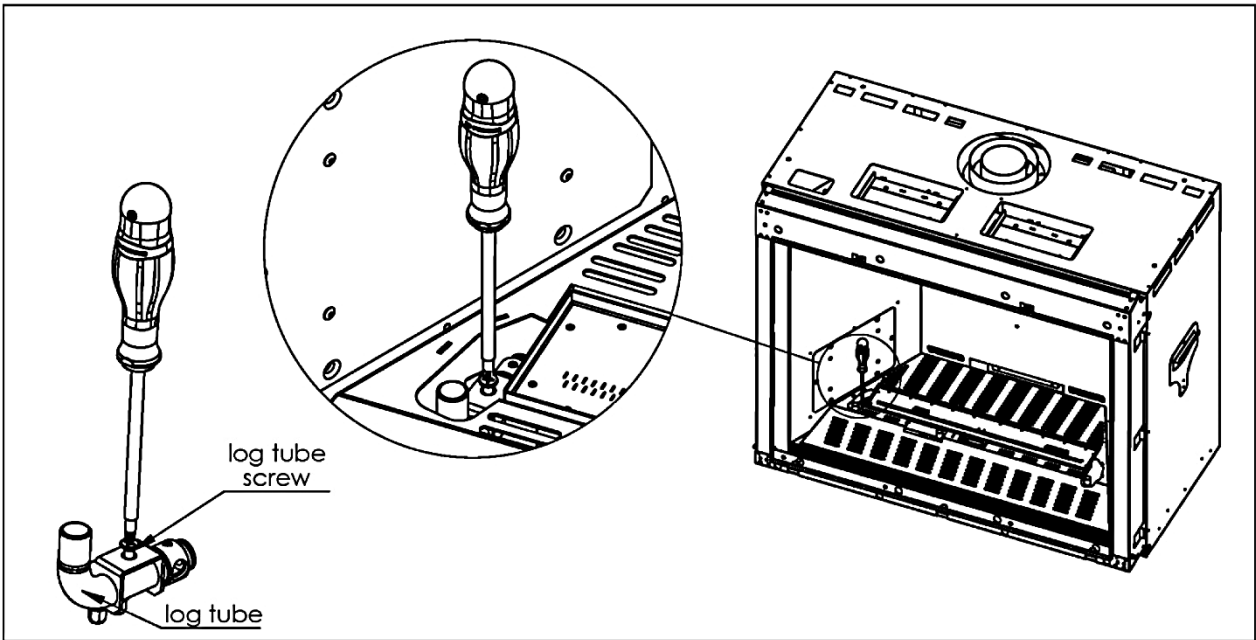

Figure(3)

### **Step 5**

Adjust the orientation of the log tube as needed, as shown in figure (4). Retighten the screw once log tube is in desired position.



Figure(4)

## Log Base Shutter Adjustment

### Step 1

Using the supplied 2.5 Allen key, loosen the shutter screw, as shown in figure (1).

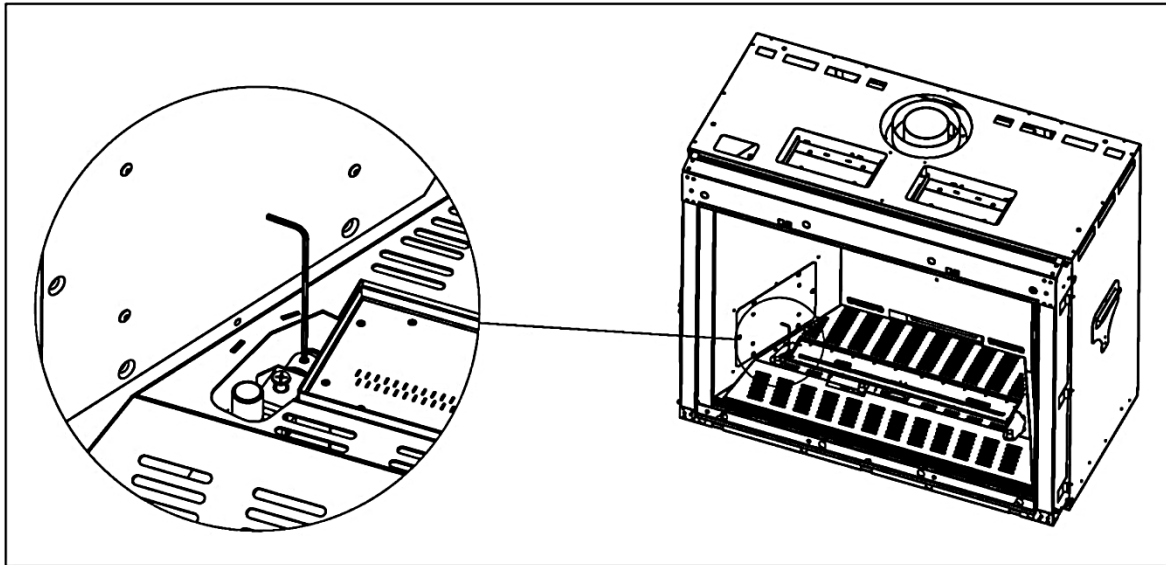

Figure(1)

### Step 2

Rotate the shutter to adjust the air flow to the log, as shown in figure (2)

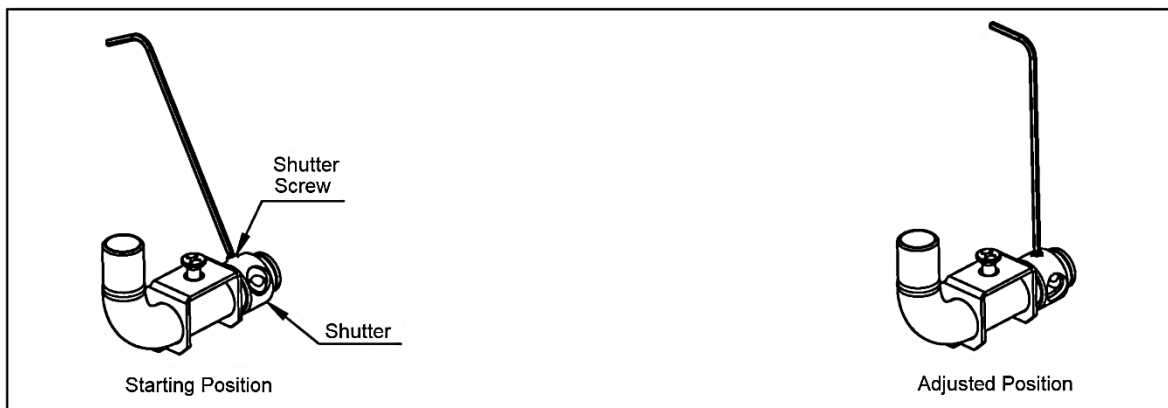

Figure(2)

# Operation

**WARNING** – Read these instructions carefully before lighting the fireplace.

Four operation options are available for use with the fireplace:

- 10-Button Remote Control Handset (default option, always included with the fireplace)
- Puck Handset (optional accessory)
- Wall Switch (optional accessory)
- MyFire Application (optional accessory)

**IMPORTANT:** The 10-Button remote control handset is always included with the fireplace regardless of which operation option is chosen. **DO NOT DISCARD.** The 10-Button remote must be kept within 26 feet of the fireplace at all times.

**NOTES:**

- Wiring of valve and receiver must be completed before starting ignition. Failure to do so could damage the electronics.
- If operating the fireplace without an AC adapter, battery replacement is recommended at the beginning of each heating season.
- Fireplaces with double glass, power vent, and/or interior lighting features must operate using the AC Adapter and therefore will not operate during a power failure.
- Only the Mertik Maxitrol AC Adapter is permitted for use with the fireplace. Use of other adapter brands can render the system inoperable. The handsets, receivers, wall switches are not interchangeable with other electronics.
- Batteries must be kept within their recommended temperature limits (32°F to 131°F).

## 10-Button Remote Control Handset

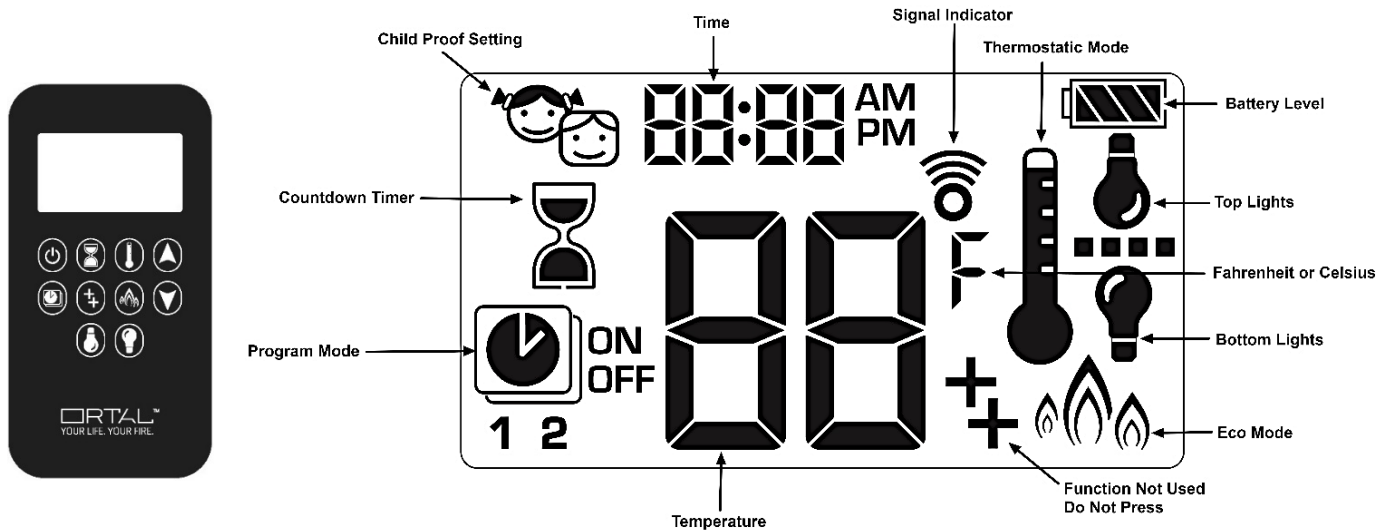

© 2019, Maxitrol Company

Control Option	Radio Frequency	Power Supply	
10-Button Handset	918.0 MHz (U.S. & Canada)	2 x 1.5V AAA batteries (quality alkaline recommended)	Replace batteries after 2 years or when low battery indicator appears on handset display
<b>IMPORTANT: For safety/communication purposes, 10-button handset must be located within 26 feet of the receiver.</b>			

**NOTE:** Any device that functions using the same radio frequency as the handset will be affected when handset is in use.

## Operating Instructions

Instructions for operating the 10-Button Handset are shown below. For more in-depth instructions, please refer to the “Homeowner’s Fireplace Operation Manual” or “Remote Operation Instructions”.

**NOTE:** Some options on the remote may not be available for all fireplaces.

## Turning the Fireplace On

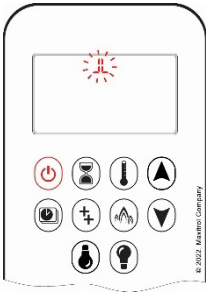

1. Press the  button until you hear continuous beeping, and a blinking series of lines confirms the start sequence has begun; release buttons.
2. Main gas flows once pilot ignition is confirmed.
3. The system automatically goes into Manual Mode after main burner ignition.

**NOTE:** When pilot ignition is confirmed, motor turns automatically to maximum flame height.

**NOTE:** If the Timer function has been set and the fireplace is manually turned on, the Timer function will need to be reset.

## Turning the Fireplace Off





1. Press the  button to turn the fireplace off.

**NOTE:** The fireplace may be turned on again after the OFF icon stops flashing.

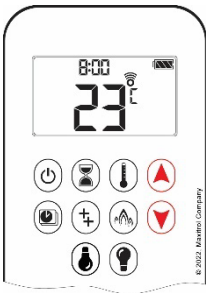
## Flame Height Adjustment



1. To increase flame height, press and hold the  button to desired flame height.
2. To decrease flame height, or to set fireplace to pilot flame only, press and hold the  button.

## Puck Handset

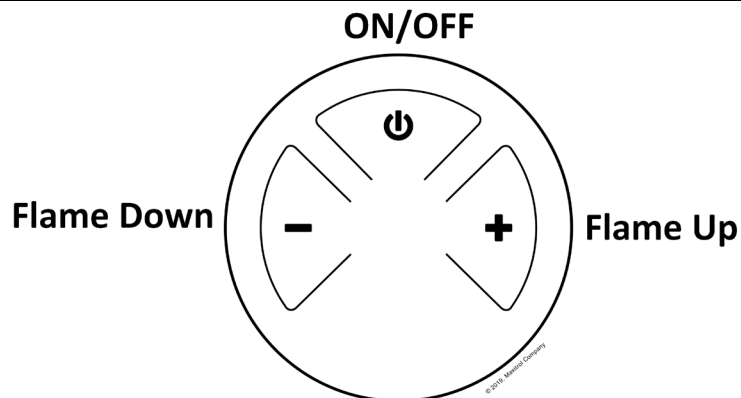

Control Option	Radio Frequency	Power Supply	
Puck Handset	918.0 MHz (U.S. & Canada)	2 x 1.5V AAA batteries (quality alkaline recommended)	Replace batteries after 2 years or when low battery indicator appears on handset display

**IMPORTANT:** For safety/communication purposes, Puck handset must be located within 26 feet of the receiver.

**NOTE:** Any device that functions using the same radio frequency as the handset will be affected when handset is in use.

# Operating Instructions

Instructions for operating the Puck Handset are shown below.

## Turning the Fireplace On/Off

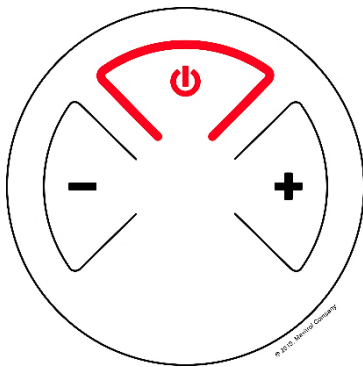

**ON:**

5. Firmly press and hold the  button until two short beeps confirms the start sequence has begun; release button.

**OFF:**

6. Firmly press the  button.

## Increase/Decrease Flame Height

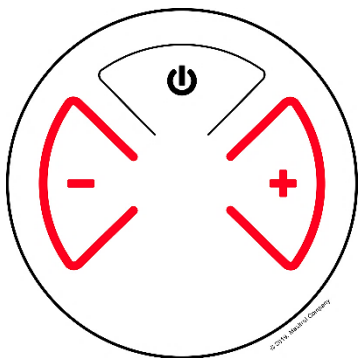

**INCREASE:**

7. To increase flame height, press and hold **+** button.

**DECREASE:**

8. To decrease flame height, press and hold **-** button.
9. Holding the **-** button long enough sets the fireplace to pilot flame (Standby Mode).

## Designated Flame Settings

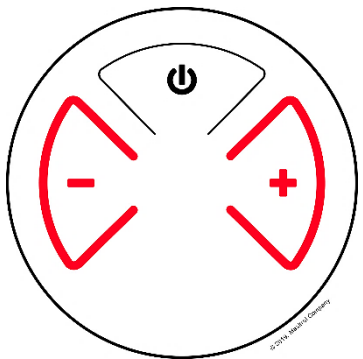

**DESIGNATED LOW FLAME SETTING**

10. To go to designated low flame setting, double-click **-** button.

 **NOTE: Flame goes to High Flame before going to Low Flame.**

**DESIGNATED HIGH FLAME SETTING**

11. To go to designated high flame setting, double-click **+** button.

## Wall Switch

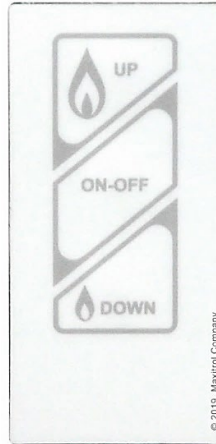

Control Option	Radio Frequency	Power Supply
Wall Switch	N/A	N/A

**IMPORTANT:** For safety/communication purposes, the 10-button handset must be located within 26 feet of the receiver.

## Operating Instructions

### Turning the Fireplace On/Off



ON/OFF

**ON:** Press and hold the **ON-OFF** button until two short beeps confirms the start sequence has begun; release button.

**OFF:** Press the **ON-OFF** button.

### Flame Height Adjustment



Flame Up

Flame Down

**INCREASE:** To increase flame height, press and hold  (up flame) button.

**DECREASE:** To decrease flame height, press and hold  (down flame) button.

Holding the  (down flame) button long enough sets the fireplace to pilot flame (Standby Mode).

## Fireplace Maintenance

### General Maintenance

All servicing, maintenance, interior cleaning and handling of the fireplace, parts and glass must be performed by an authorized Ortal dealer service technician only.

### Servicing

- Turn off the gas and electricity BEFORE servicing the fireplace.
- It is recommended that a routine inspection is performed at the beginning of each heating season.
- When removing glass from multisided fireplaces, only one side of glass can be removed at a time. Glass must be re-installed before removing glass from a different side.

## Burner and Vent Inspections

---

- Periodic checks should be made of the burner for correct position and condition. Visually check the flame of the burner, making sure that the flames are steady.
- The vent system must be inspected before use. Annual inspection must be scheduled to ensure the flow of combustion and ventilation air.

## Metallic Noise

---

- Noise is caused by metal expanding and contracting as it heats up and cools down, like noise produced from a furnace. The noise does not affect the operation or longevity of the fireplace.
- These minor expansion, contractions or movement of parts causing noise are normal. Complaints related to these noises are not covered by warranty.

## Submerged Parts

---

- Do not use the fireplace if any part has been under water, or if you suspect that it may have been under water. The Ortal dealer service technician must inspect and, if necessary, replace any parts of the control system and any gas controls which have been under water.

## Handling the Glass

---

Inner glass panel is 5mm ceramic glass. Exterior double glass panel is 3/16" tempered glass. Tempered glass can be sourced locally if replacement becomes necessary. Ceramic glass must be provided by Ortal.

- When removing glass from multisided fireplaces, only one side of glass can be removed at a time. Glass must be re-installed before removing glass from a different side.
- **NEVER** operate the fireplace without the glass properly secured in place.
- The glass must be removed **ONLY** by an authorized Ortal dealer service technician.
- Only an Ortal certified installer is authorized to remove the glass. Glass must be removed using an 8-inch glass-handling suction cup. Lower the glass to rest in a safe place to prevent damage to the glass edges.

## Cleaning the Fireplace

---

- Only an Ortal dealer service technician can open the fireplace to clean interior surfaces.
- **ALWAYS** turn off the gas valve before cleaning.
- Do **NOT** clean when hot. Make sure fireplace has had time to cool prior to cleaning any surface or component, interior or exterior.
- Keep the fireplace clean by brushing and/or vacuuming at least once a year. This can only be performed by an Ortal dealer service technician.
- When removing glass from multisided fireplaces, only one side of glass can be removed at a time. Glass must be re-installed before removing glass from a different side.
- Clean the glass when it starts to look cloudy. Use a damp cloth for cleaning the fireplace and the door.
- Verify correct operation after servicing.

## Maintenance Frequency and Equipment Checklist

---

- Under normal circumstances, the factory recommendation is to have the fireplace serviced at least once a year. Fireplaces meeting the following conditions should have more frequent service:
- Fireplaces installed in commercial/public spaces should be serviced every 3 months.
- Fireplaces installed in climates near the ocean or in other settings where corrosion buildup is more likely should be serviced every 6 months.
- Thermocouple Maintenance:
- The thermocouple should be replaced annually or as needed in all commercial installations, and in any residential fireplace where the fireplace is operated for an average of 10 hours or more per day.
- For all other installations, the thermocouple should be replaced every three years or as needed.

© Ortal 2026  
Version 2.9, March 2026  
SKU: KPMANWILDTRV2.9

Ortal USA  
2125 Citygate Drive, Columbus, OH 43219  
T: (818) 238-7000 | F: (818) 678-0541  
info@ortalheat.com | www.ortalheat.com